

General Description

Series D3W directional control valves are high-performance, 4-chamber, direct operated, wet armature, solenoid controlled 3 or 4-way valves. They are available in 2 or 3-position and conform to NFPA's D05, CETOP 5 mounting patterns.

Features

- Worldwide, high flow, low pressure drop design.
- Soft shift available.
- 22 spools available including proportional.
- DC surge suppression available to protect electrical equipment.
- Three electrical connection options.
- AC & DC lights available.
- Easy access mounting bolts.
- Explosion proof availability.
- CSA approved.
- No tools required for coil removal.
- Rectified coils available for high flow AC applications.



Response Time (ms)

Signal to 95% spool stroke measured at 172 Bar (2500 PSI) and 75 LPM (20 GPM)

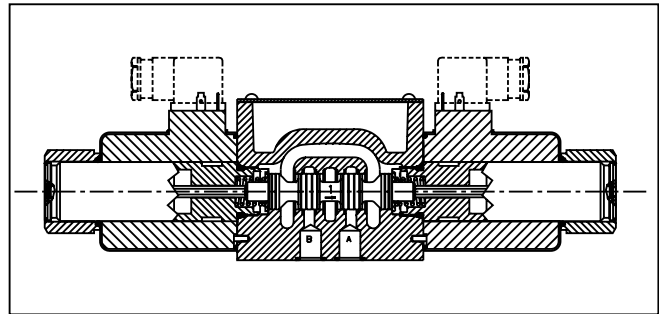
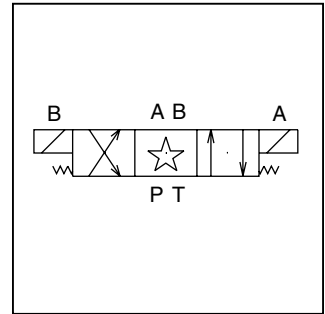
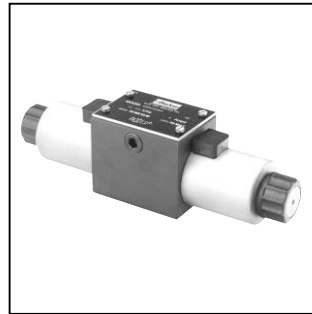
Solenoid Type	Pull-In	Drop-Out
AC Energize	10	21
AC De-energize	25	35
DC Energize	62	110
DC De-energize	58	85



Specifications

Interface	NFPA D05, CETOP 5, NG 10
Max. Operating Pressure	P, A, B: 345 Bar (5000 PSI) Standard CSA  207 Bar (3000 PSI) Tank: 103 Bar (1500 PSI) AC Standard 207 Bar (3000 PSI) AC Optional DC/AC Rectified Standard CSA  103 Bar (1500 PSI)
CSA File Number	LR060407
Leakage Rates 100 SSU @ 49°C (120°F)	Maximum Allowable: 19.6 cc (0.38 Cu. in.) per Minute/ Land @ 69 Bar (1000 PSI)* 35 cc (2.19 Cu. in.) per Minute/ Land @ 207 Bar (3000 PSI)*

* #008 and #009 Spools may exceed these rates, consult factory



A

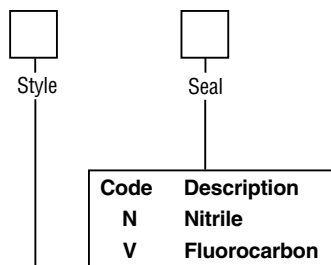
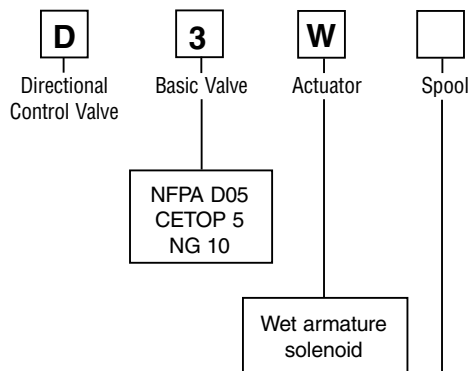

Code	Description
E#	24/60 - 24/50 VAC
Y	120/60 - 110/50 VAC
T	240/60 - 220/50 VAC
K	12 VDC
J	24 VDC
D#	120 VDC
U#	98 VDC
Z#	250 VDC

High Watt Coil only.

Code	Symbol	Code	Symbol
1		14	
2		15	
3		16	
4		20*	
5		21†	
6		22†	
7		26*†	
8*		30**	
9**		81†	
10†		††	
11		82†	
12		††	

Code	Description	Symbol
B*	Single solenoid, 2 position, spring offset. P to A and B to T in offset position	
C	Double solenoid, 3 position, spring centered.	
D†	Double solenoid, 2 position, detent	
E	Single solenoid, 2 position, spring centered. P to B and A to T when energized.	
F**	Single solenoid, 2 position. Spring offset, energized to center position. Spool spacer on A side. P to A and B to T in spring offset position.	
H*	Single solenoid, 2 position, spring offset. P to B and A to T in offset position.	
K	Single solenoid, 2 position. Spring centered. P to A and B to T when energized.	
M**	Single solenoid, 2 position, spring offset, energized to center position. Spool spacer on B side. P to B and A to T in spring offset position.	

* Only spools 20, 26 & 30.

** High Watt Coil.

† Only spools 20 & 30.

This condition varies with spool code.

* 8, 20 & 26 spools have closed crossover.

** 9 & 30 spools have open crossover.

† Available only with high-watt rectified AC coils or high-watt DC coils.

†† Spring centered versions C, E, F, K & M only.

Valve schematic symbols are per NFFA/ANSI standards, providing flow P to A when energizing solenoid A. Note operators reverse sides for #8 and #9 spools. See installation information for details.

Bold: Designates Tier I products and options.

Non-Bold: Designates Tier II products and options. These products will have longer lead times.

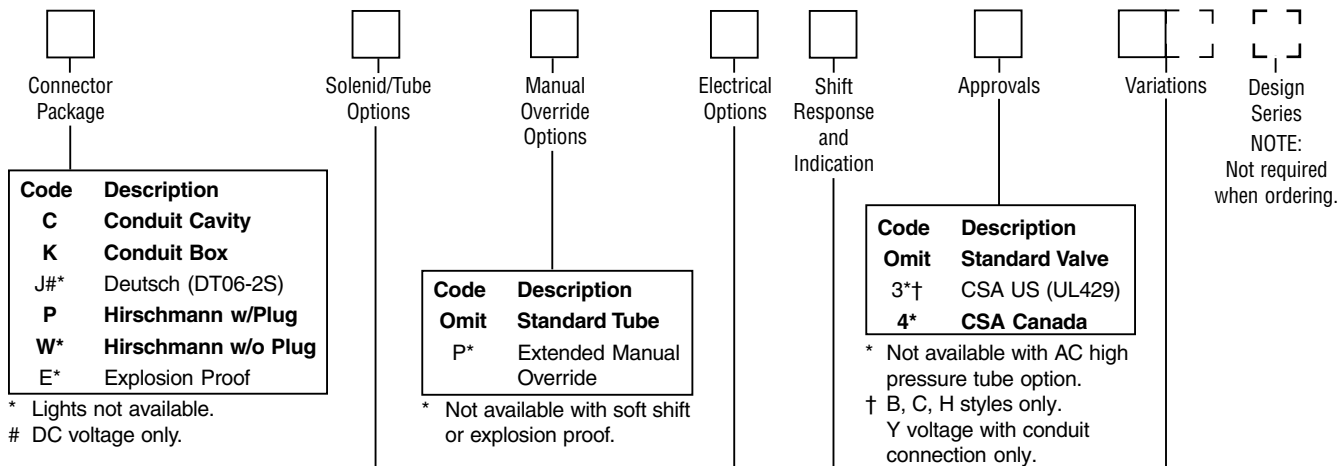

Code Description
C Conduit Cavity
K Conduit Box
J#* Deutsch (DT06-2S)
P Hirschmann w/Plug
W* Hirschmann w/o Plug
E* Explosion Proof

* Lights not available.
 # DC voltage only.

Code Description
Omit Standard Tube
P* Extended Manual Override

* Not available with soft shift or explosion proof.

Code Description
Omit Standard Valve
3*† CSA US (UL429)
4* CSA Canada

* Not available with AC high pressure tube option.

† B, C, H styles only.
 Y voltage with conduit connection only.

Options	Coil	Tube Rating	
		AC	DC/AC Rectified
Omit	High Watt	103.5 Bar (1500 PSI)	207 Bar (3000 PSI)
F*#	Low Watt	n/a	207 Bar (3000 PSI)
H	High Watt	207 Bar (3000 PSI)	n/a
D†	Explosion Proof, EEXD		
U†	Explosion Proof, UL/CSA		

* Available only with J, K, Y (Rectified) and T (Rectified) voltages.
 # Not available with soft shift or with F and M style valves.
 † Explosion proof coils are 60 Hz at standard voltage; dual rating not available.

Code Description
Omit Standard Valve
S3 Soft Shift, 0.030" Orifice**
S4 Soft Shift, 0.040" Orifice**
S7 Soft Shift, 0.070" Orifice**
I7* Monitor Switch Direct Op. End Stroke
I8* Monitor Switch

* Single solenoid models only. Not CE or CSA approved. Spools 8, 9, 81 & 82 not available.
 ** High watt coil only.

Valve Weight:

Single Solenoid:

AC 4.3 kg (9.5 lbs.)
 DC 5.3 kg (11.6 lbs.)

Double Solenoid:

AC 5.0 kg (11.0 lbs.)
 DC 7.3 kg (16.0 lbs.)

Standard Bolt Kit: BK98

Metric Bolt Kit: BKM98

Code Description
Omit No Option
V# Varistor Surge Suppressor
Z AC Rectified with MOV Surge Suppressor

DC voltage only.

Mounting Bolt Kits

UNC Bolt Kits for use with D3W Directional Control Valves & Manapak/Cartpak					
		Number of Manapaks/Cartpaks @ 2.00" (50mm) thickness			
		0	1	2	3
D3W	Standard:	BK98 1.62"	BK141 3.50"	BK142 5.50"	BK143 7.50"
	Metric:	BKM98 40mm	BKM141 90mm	BKM142 140mm	BKM143 190mm
D3W with explosion proof coils	Standard:	BK144 2.37"	BK61 4.25"	BK62 6.25"	BK63 8.25"
	Metric:	BKM144 60mm	BKM61 110mm	BKM62 160mm	BKM63 210mm

NOTE: All bolts are SAE grade 8, 1/4-20 UNC-2A thread, torque to 16 Nm (12 ft-lbs)

Code Description
Omit Standard Valve
5 Signal Lights
6 Manaplug, Brad Harrison Mini
7 Manaplug, Brad Harrison Micro (M12x1)
56 Manaplug (Mini) with Lights
57 Manaplug (Micro) with Lights (M12x1)
1A Manaplug (Mini) Single Sol. 5-Pin
1B Manaplug (Micro) Single Sol. 5-Pin (M12x1)
1C Manaplug (Mini) Single Sol. 5-Pin w/Lights
1D Manaplug (Micro) Single Sol. 5-Pin w/Lights (M12x1)

Bold: Designates Tier I products and options.

Non-Bold: Designates Tier II products and options. These products will have longer lead times.

Solenoid Ratings**

Insulation	Class H
Allowable Deviation from rated voltage	DC, AC Rect -10% to +15% AC -5% to +5%
Armature	Wet pin type

** DC Solenoids available with optional molded metal oxide varistor (MOV) for surge suppression.
 Leadwire length 6" from coil face.

D3W**F Solenoid Electrical Characteristics†**

Solenoid Code	Nominal Volts/Hz	In Rush Amps	Holding Amps	Watts
KF	12 VDC	—	1.50	18
JF	24 VDC	—	0.75	18

† Based on nominal voltage @ 22°C (72°F)

D3W Solenoid Electrical Characteristics†

Solenoid Code	Nominal Volts/Hz	In Rush VA	Holding VA	Nominal Watts (Ref)
Y	120/60	298	95	32
	110/50	294	102	
T	240/60	288	96	32
	220/50	288	101	
E	24/60	290	77	32
	24/50	381	110	
K	12 VDC	—	3.00†	36
J	24 VDC	—	1.50†	36
D	120 VDC	—	0.30†	36
U	98 VDC	—	0.37†	36
Z	250 VDC	—	0.14†	36

† DC holding amps.

D3W Rectified AC Solenoid Electrical Characteristics†

Solenoid Code	Nominal Volts/Hz	In Rush Amps	Holding Amps	Watts
Y	120/60	—	.37	36
	110/50	—	.37	
T	240/60	—	.18	36
	220/50	—	.18	
YF	120/60	—	.18	18
	110/50	—	.18	
TF	240/60	—	.09	18
	220/50	—	.09	

† Based on nominal voltage @ 22°C (72°F)

Explosion Proof Solenoids

Explosion Proof Solenoid Ratings

U.L. (EU) C.S.A.	Class I, Div. 1 & 2, Groups C & D Class II, Div 1 & 2, Groups E, F & G As defined by the N.E.C
ATEX	Complies with ATEX requirements for: Exd, Group IIB; EN50014: 1999+ Amds 1 & 2, EN50018: 200

Electrical Characteristics* ED and EU†

Solenoid Code	Nominal Volts/Hz	In Rush VA	Holding VA	Nominal Watts (Ref)
Y	120/60	266	82	36
T	240/60	266	82	36
K	12 VDC	—	3.00†	36
J	24 VDC	—	1.50†	36
D	120 VDC	—	0.30†	36

* Dual frequency not available on explosion proof coils.

† DC holding amps.

Inch equivalents for millimeter dimensions are shown in (**)

Hirschmann, Double AC Solenoid

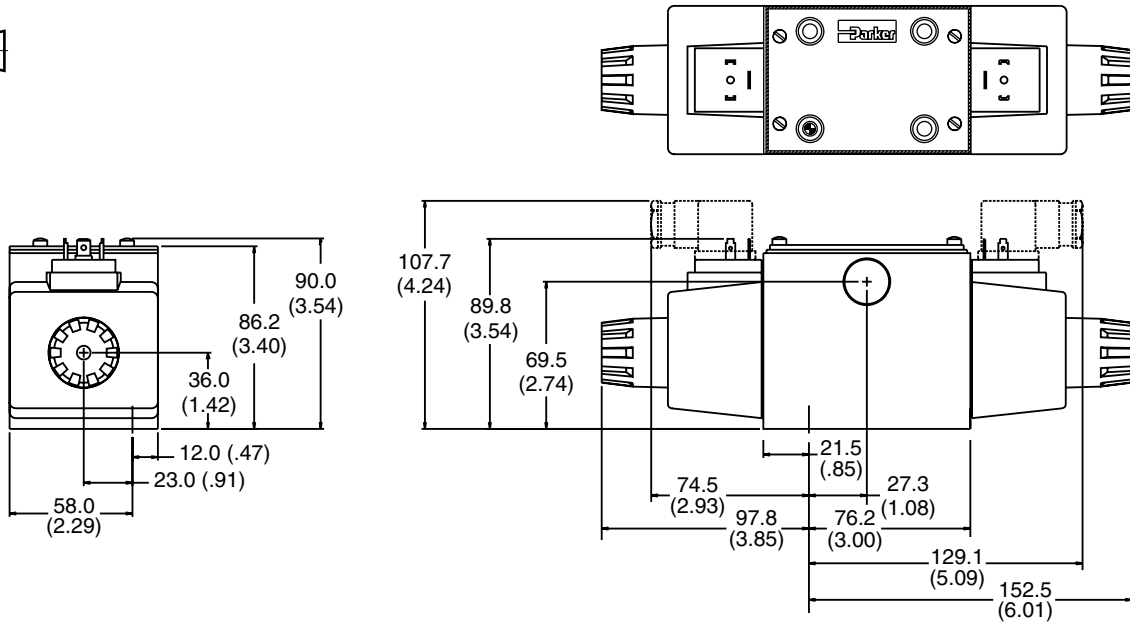
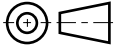

Note: 30.0mm (1.18") from bottom of bolt hole counterbore to bottom of valve.

Hirschmann, Single AC Solenoid

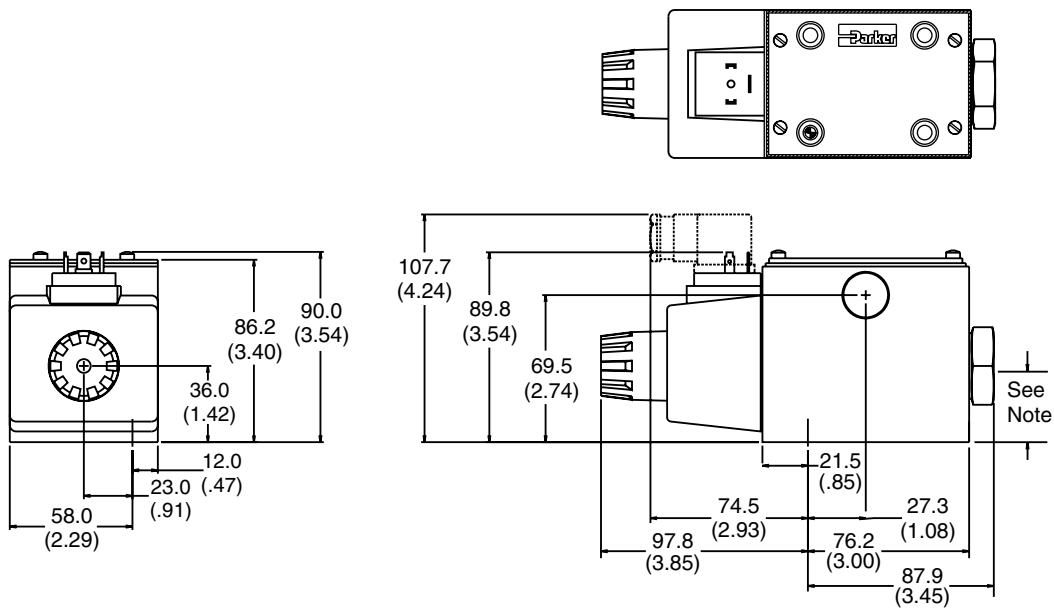

Note: 30.0mm (1.18") from bottom of bolt hole counterbore to bottom of valve.

Inch equivalents for millimeter dimensions are shown in (**)

A

Conduit Cavity, Double DC Solenoid

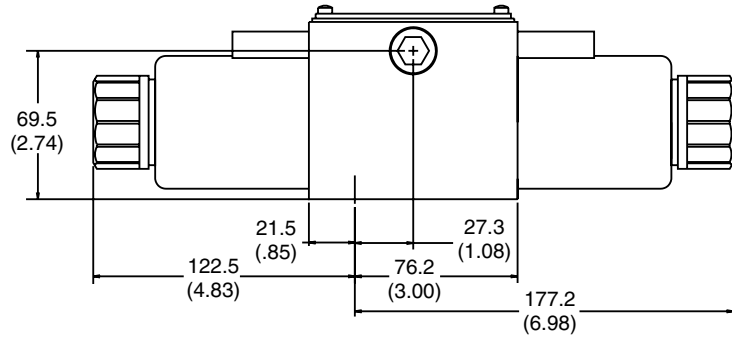
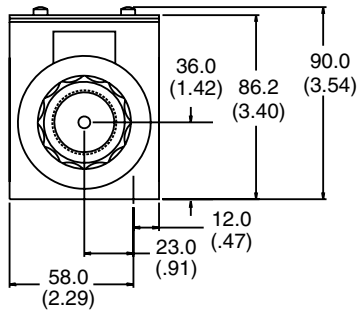
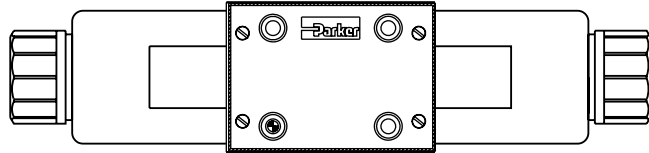
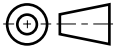

Note: 30.0mm (1.18") from bottom of bolt hole counterbore to bottom of valve.

Conduit Cavity, Single DC Solenoid

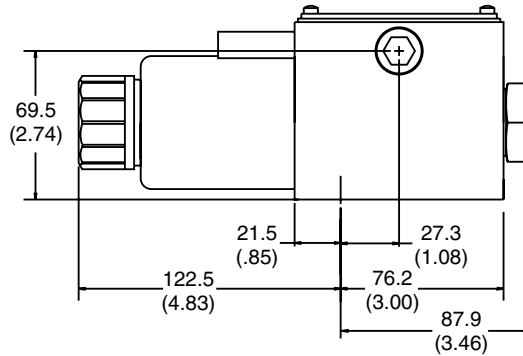
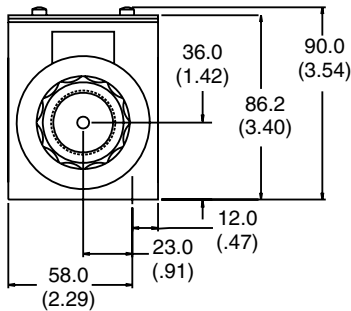
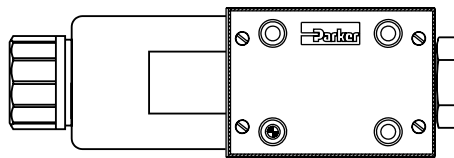

Note: 30.0mm (1.18") from bottom of bolt hole counterbore to bottom of valve.

Inch equivalents for millimeter dimensions are shown in (**)

**Conduit Box, Single AC Solenoid
with Variation 6 (Manaplug) & Variation P (Extended Manual Override)**

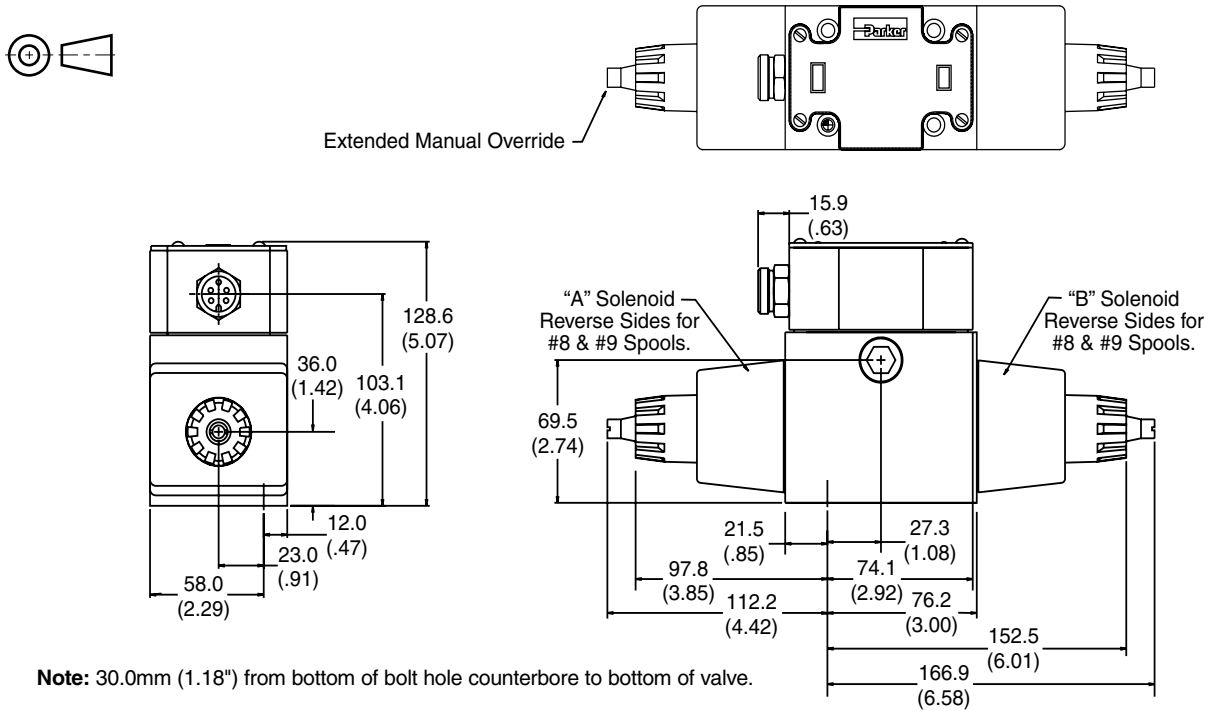

**Conduit Box, Double DC Solenoid
with Variation 6 (Manaplug) & Variation P (Extended Manual Override)**

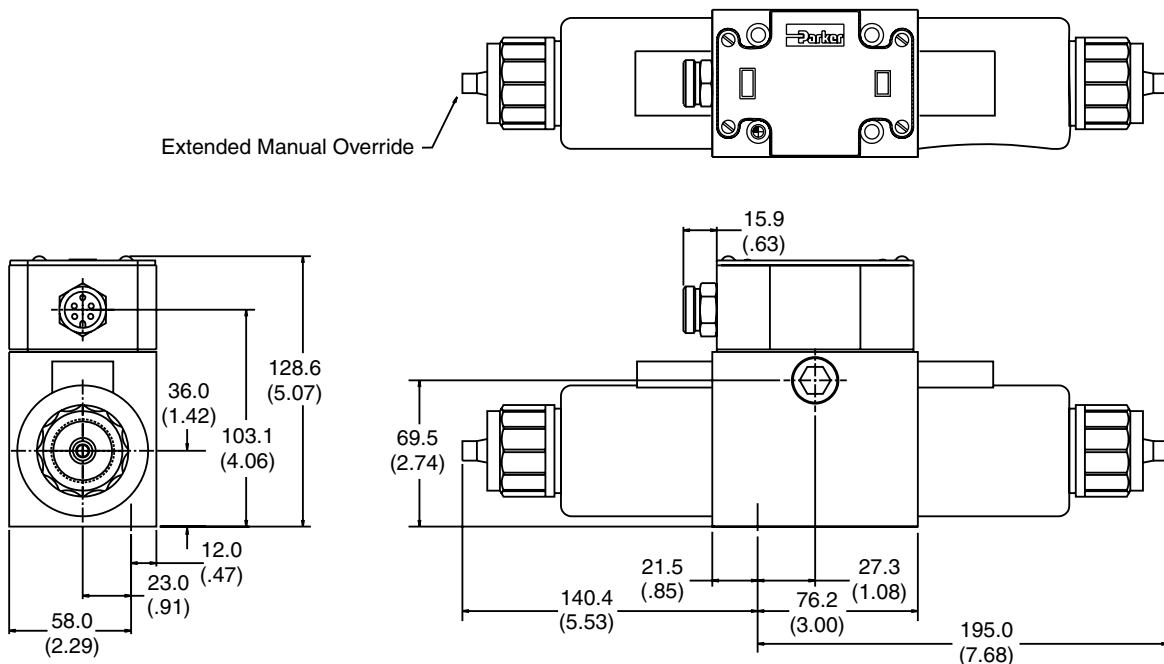

Inch equivalents for millimeter dimensions are shown in (**)

A

Explosion Proof U.L. & CSA, Double Solenoid

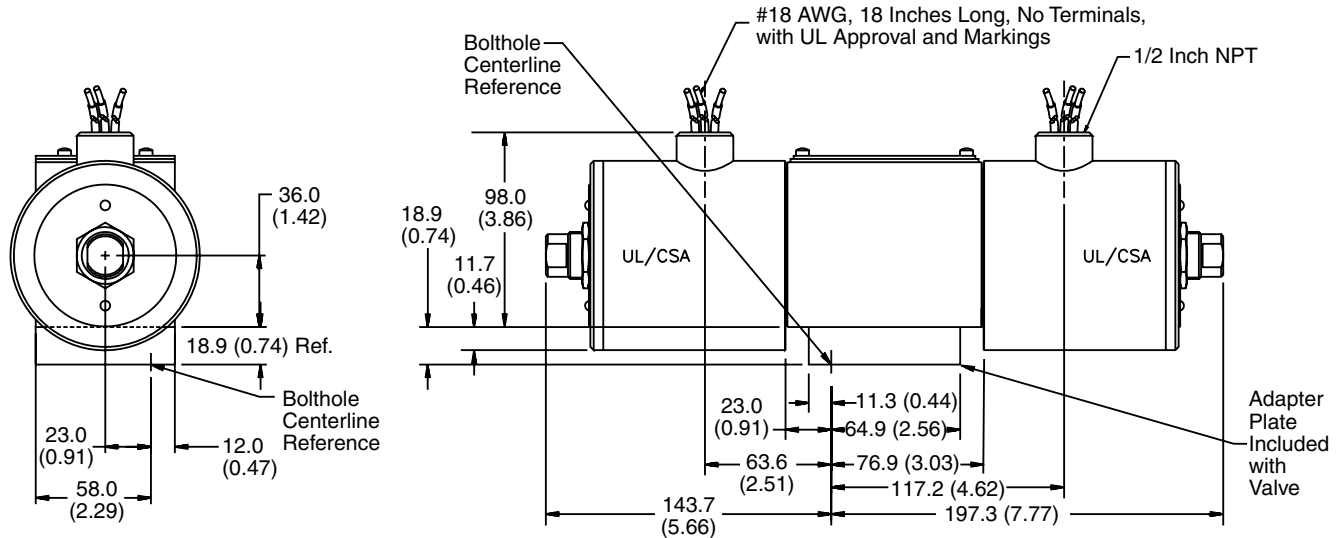
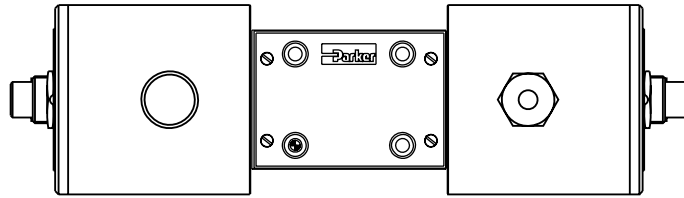
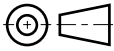

Note: Mounting bolts included with valve.

Explosion Proof ATEX, Double Solenoid

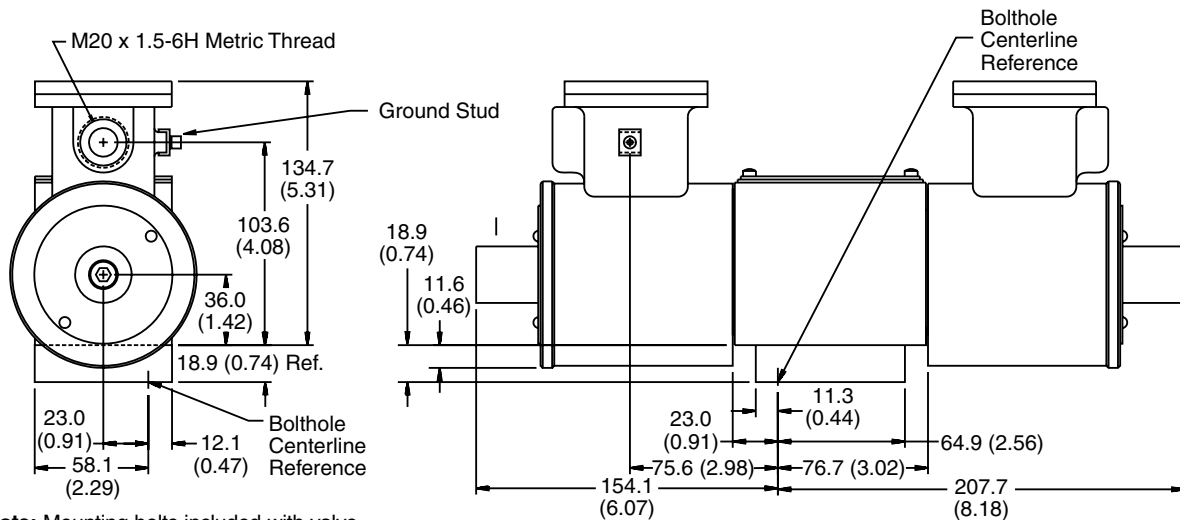
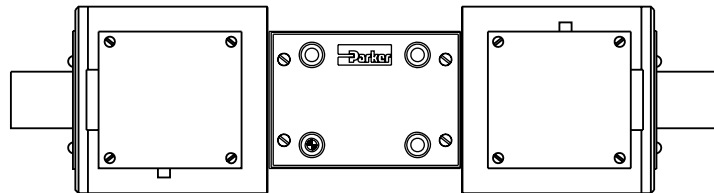

Note: Mounting bolts included with valve.

2502-A2.p65, dd



Inch equivalents for millimeter dimensions are shown in (**)

**Conduit Box, Single DC Solenoid
with Variation I7 (Monitor Switch)**

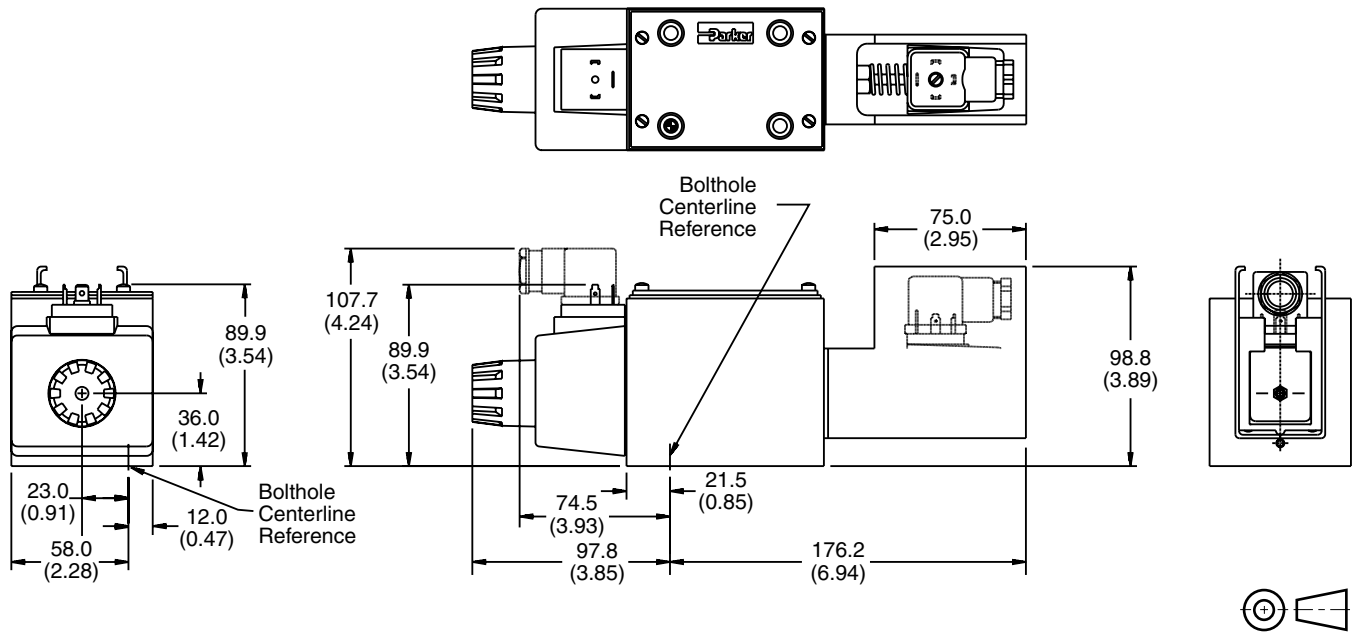

Note: 30.0mm (1.18") from bottom of bolt hole counterbore to bottom of valve.

**Monitor Switch
(valve variation I7) Start of Stroke**

This feature provides for electrical confirmation of the spool shift. This can be used in safety circuits, to assure proper sequencing, etc.

Switch Data

Inductive switch requiring +18-42 volt input. Outputs "A" and "B" are opposite; one at "0" voltage, the other at input voltage. During switching, "A" and "B" outputs reverse. Provides 0.4A switching current.

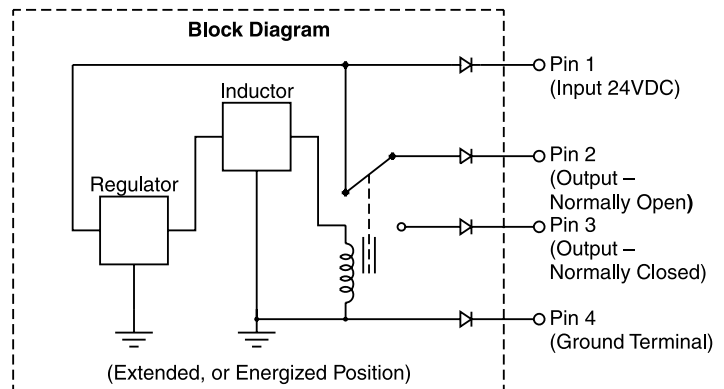

For repetitive switch power-up conditions, please consult factory.

Conduit Box
(connection option K)

- Interface – 152.4 cm (6.0 inch) lead wires, 18 awg.
- Meets NEMA 4 and IP67

Manaplug
(valve variations 6, 56, 1A, 1C)

- Interface – Brad Harrison Plug
- 3-Pin for Single Solenoid
- 5-Pin for Double Solenoid

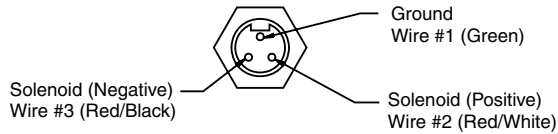

3-Pin Manaplug (Mini) with Lights
 Single Solenoid Valves – Installed Opposite Side of Solenoid

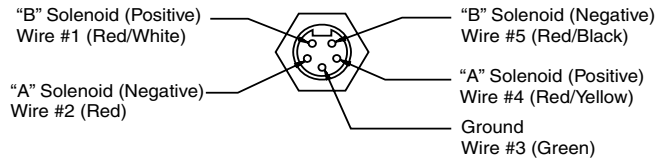

5-Pin Manaplug (Mini) with Lights
 Single Solenoid Valves – Installed Opposite Side of Solenoid
 Double Solenoid Valves – Installed Over "A" Solenoid
 ("A" and "B" Solenoids Reversed for #8 and #9 Spools)

Pins are as seen on valve (male pin connectors).

Hirschmann Plug with Lights (P5)

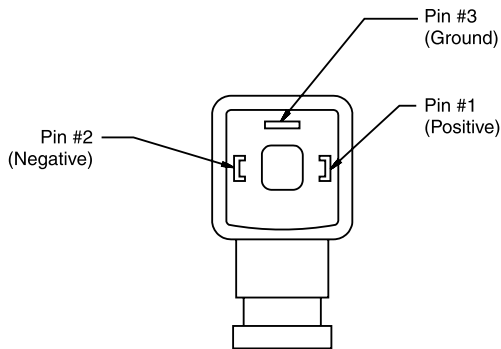

Face View of Plug

Conforms to DIN43650, ISO4400, Form A 3-Pin

Manaplug - Micro Connector
(valve variations 7, 57, 1B, 1D)

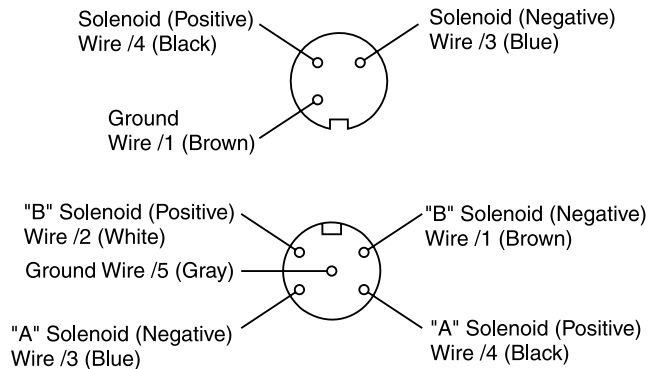

Pins are as seen on valve (male pin connectors).

Fluid Recommendations

Premium quality hydraulic oil with a viscosity range between 32-54 cSt (150-250 SSU) at 38°C (100°F) is recommended. The absolute operation viscosity range is from 16-220 cSt (80-1000 SSU). Oil should have maximum anti-wear properties and rust and oxidation treatments.

Fluids and Seals

Valves using synthetic, fire-resistant fluids require special seals. When phosphate ester or its blends are used, FLUOROCARBON seals are required. Water-glycol, water-in-oil emulsions, and petroleum oil may be used with NITRILE seals.

Temperature Recommendation

Recommended oil temperature:
-29°C to +71°C (-20°F to +160°F)

Filtration

For maximum valve and system component life, the system should be protected at a contamination level not to exceed 125 particles greater than 10 microns per milliliter of fluid. (SAE Class 4 or better, ISO Code 16/13).

Tank Line Surges

If several valves are piped with a common tank line, flow surges in the line may cause unexpected spool shift. Detent style valves are most susceptible to this. Separate tank lines should be used when line surges are expected in an application.

Recommended Mounting Position

Valve Type	Recommended Mounting Position
Detent (Solenoid)	Horizontal
Spring Offset	Unrestricted
Spring Centered	Unrestricted

Silting

Silting can cause any sliding spool valve to stick and not spring return, if held shifted under pressure for long periods of time. The valve should be cycled periodically to prevent sticking.

Single Pass Operation

Valve flow ratings are for double pass operation (with equal flow in both paths). When using these components in single pass applications, flow capabilities may be reduced. Consult your local Parker representative for details.

Flow Path Data

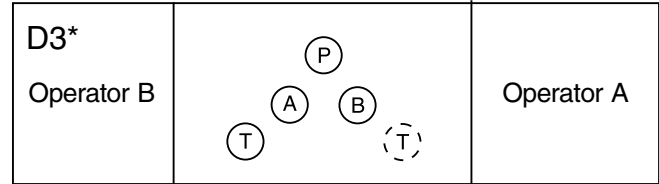

*Note: On valves with 008 or 009 spool, A and/or B operators reverse sides. Flow paths remain the same as viewed from top of valve.



Double Solenoid. With solenoid “A” energized, flow path is P→A and B→T. When solenoid “B” is energized, flow path is P→B and A→T. The center condition on a spring-centered valve exists when both coils are de-energized, or during a complete shift, as the spool passes through center.

Detent and Spring Offset. The center condition exists on detent and spring offset valves only during spool crossover. To shift and hold a detented spool, only a momentary energizing of the solenoid is necessary. The minimum duration of the signal is approximately 0.13 seconds for both AC and DC voltages. This position will be held provided the spool center line is in a horizontal plane, and no shock or vibration is present to displace the spool.

Single Solenoid. Spring offset valves can be ordered in six styles: B, E, F, H, K and M. Flow path data for the various styles are described in the order chart.

Lever Operated (on B end)

Pull lever away from valve P→A; B→T
Push lever toward valve P→B; A→T

Note: Reverse with a #8 or #9 spool.

Electrical Failure

Should electric power fail, spring offset and spring centered valves will shift to the spring held position. Detented valves will stay in the last position held before power failure. If main flow does not fail or stop simultaneously, machine actuators may continue to function in an undesirable manner or sequence.

Loss of Pilot Pressure (D3A)

Should a loss of pilot pressure occur, spring offset and spring centered valves will shift to the spring held position. Detented valves will remain in the last position held. If main hydraulic flow does not simultaneously stop, machine actuators may continue to function in an undesirable manner or sequence.

Torque Specifications

Torque values recommended for the bolts which mount the valve to the manifold or subplate are as follows:

1/4-20 thread (M6x1) torque 16.0 Nm (12 ft-lbs).