



# DX Fluid Products

*Innovative products for effective fluid handling  
in 2.5 and 12 liter units.*





*High performance without compromising the environment*

# DX Fluid Handling

*– products for a multitude of applications*

*The powerful CEJN Series DX is the ultimate product for you when it comes to quick and safe fluid handling. It not only improves your work environment with its innovative functions, it also makes it safer due to its many protection features.*

The special feature of the DX that sets it apart from all other fluid handling products is its overpressure function. This built-in function drains the DX and enables you to refill the extracted fluid automatically, without any risk of spillage. Never has recycling fluids been easier or safer.

The DX is powered by compressed air but can be vacuum pre-charged. So no place is too remote for the DX, leaving you with a product without the limitations of a compressed air installation. This in combination with its multi-fluid function, which enables you to extract virtually all types of non-flammable fluids, make the DX the only product you need for a multitude of applications.

Custom make your own complete fluid handling system by choosing from the wide variety of accessories included in the DX range. A system that fulfils your every need and perfectly suits your requirements is only a few choices away.





# DX Functionality

– *smart solutions for all occasions*

The CEJN DX extracts fluids quickly and safely to its canister via vacuum and drains it by generating a slight overpressure. This ensures no spillage, which results in not only an improved and cleaner work environment but also prevents operator-injury caused by contact with aggressive-type fluids.

The CEJN DX has universal seals that enable it to safely handle virtually all non-flammable fluids. It is powered by standard shop air and can also work remotely due to its vacuum pre-charging function. The DX is available with a 2.5-liter or 12-liter canister and are both interchangeable with the DX-handle. These combined features, make the DX a versatile product for a multitude of applications in every corner of the world.

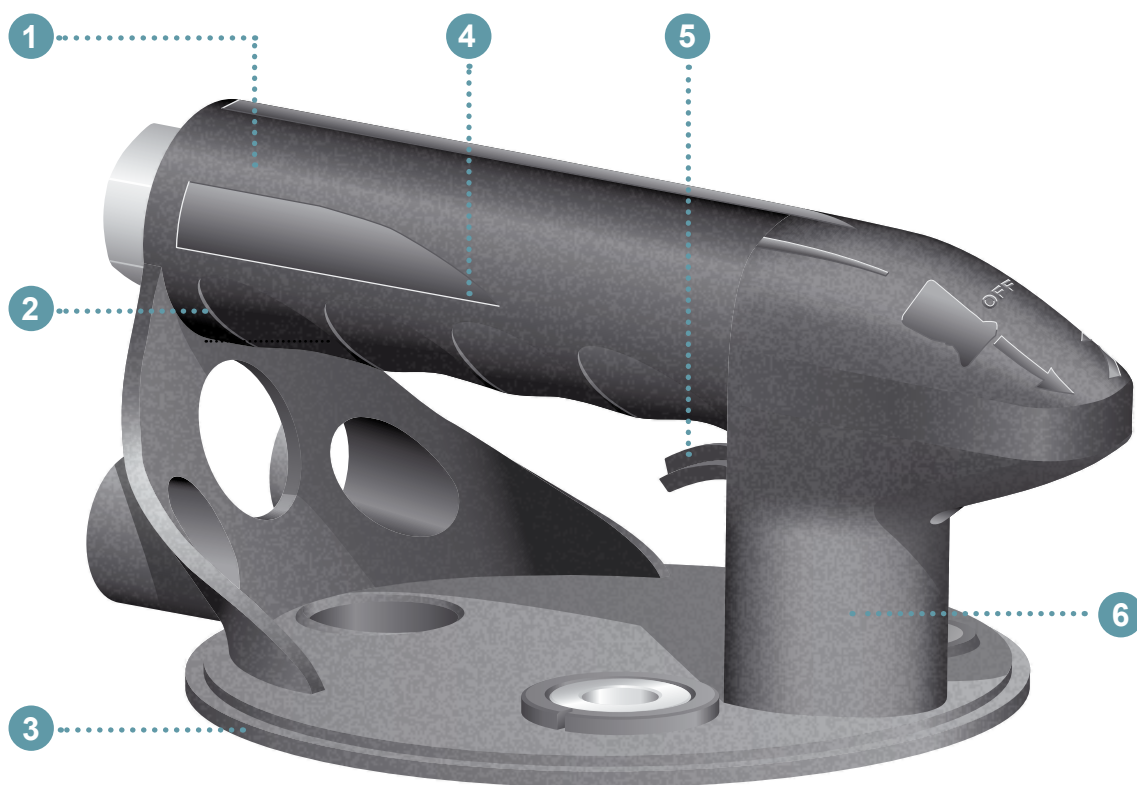

## Many Sought-After Features

With more than 30 years of experience of fluid handling, CEJN has developed this patent-pending and flexible product with many sought-after safety and design features, including:

1. *An ergonomically designed handle that is easy to use and all functions are near at hand.*
2. *A dual safety design that prevents the overpressure of the canister to become too high. In addition, a gauge helps to keep track of the canister-pressure and vacuum.*
3. *Universal seals enable the Series DX to be used for safely extracting all kinds of non-flammable fluids, even aggressive-type brake fluids.*
4. *A built-in silencer enables a noise level below 80 dB (A) that guards against work place injuries induced by excessive noise.*
5. *An activation button prevents accidental activation of the pressure-mode.*
6. *A floater in the lid bottom automatically shuts off the vacuum mode to protect the canister from overfilling.*

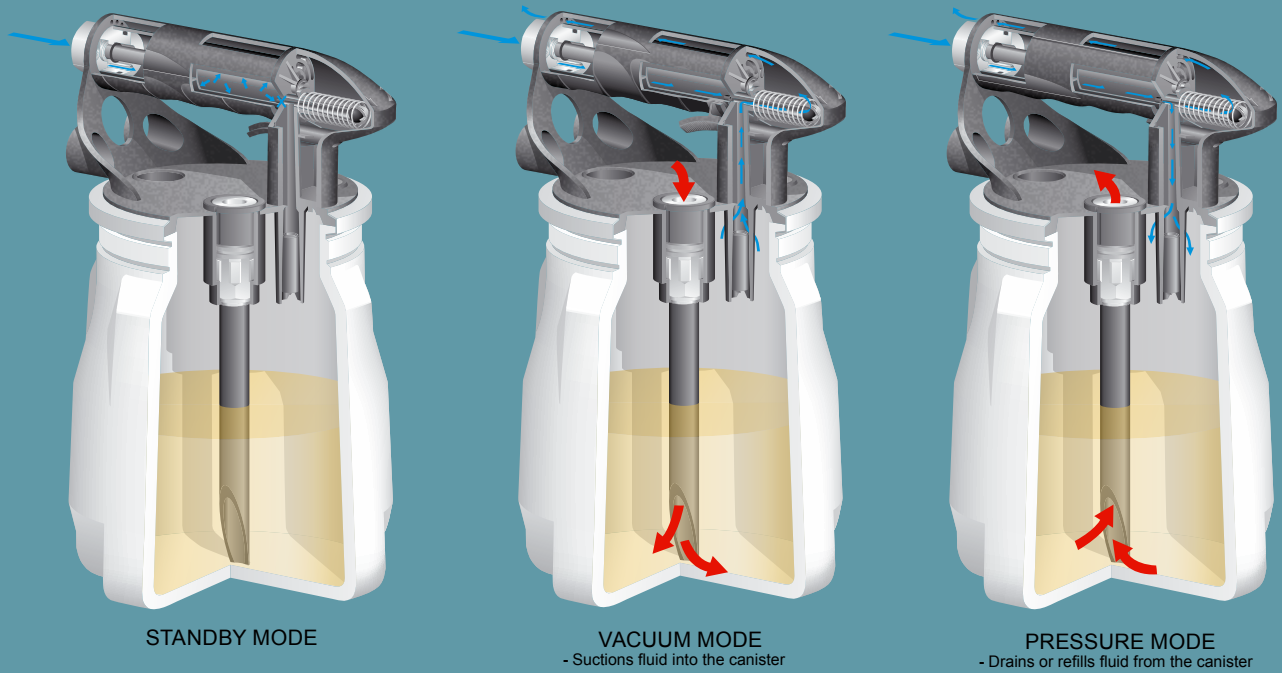

## How to Use the DX

The CEJN DX is extremely easy to use, you simply turn the handle once to engage the vacuum mode and start the extraction of fluid. Another turn in the opposite direction engages the pressure mode and generates a slight overpressure, which drains the fluid from the canister. To activate the pressure mode you must also release the activation button on the handle. This safety feature prevents accidental pressurization and potential operator injury.

With its well-balanced design and well-thought through choices of high-quality material, the CEJN DX offers you a product with high-performance and long, maintenance-free service life.



# DX Technical Data

CEJN Series DX offers ready-to-use fluid handling units for automotive and industrial applications. Accessory kits for a multitude of usage are available.

- **Multi fluid function**
- **Overpressure function**
- **Vacuum pre-charging function**

## Technical Data

Media..... Brake fluid, engine oil, transmission fluids and other non-explosive liquids.  
 Working pressure ..... 5.5 to 12 bar (79 to 174 PSI)  
 Optimal working pressure..... 6.5 bar (94 PSI)  
 Max. air consumption (pressure mode) .... 35 l/min at 6 bar (1.2 CFM at 87 PSI)  
 Max. air consumption (vacuum mode)..... 80 l/min at 6 bar (2.8 CFM at 87 PSI)  
 Vacuum..... Max. 85%  
 Air connection..... 1/4"  
 Noise level ..... 79 dB(A) at 6 bar

## Logistic Data

	<b>DX2.5</b>	<b>DX12</b>
Box dimensions .....	180x180x300 mm	255x255x550 mm
Bar codes EAN .....	7391390241481	7391390241498

## Different Sizes for Different Applications

The DX2.5 has a 2.5-liter canister and comes with an evacuation hose and a suction hose equipped with a universal bleed adapter. It is perfectly suited for automotive applications, in particular brake bleeding. Available are accessories to further optimize the DX2.5 to your specific automotive needs, e.g. an automatic refiller bottle and an extension hose. The DX2.5 can also be used in industrial applications where space is limited or volumes below 2.5 liters are to be extracted.

The larger DX12-unit is optimal for industrial applications that demand a greater volume-handling ability, such as maintenance work, waste evacuation and fluid refilling. It has a canister of 12 liters and comes equipped with a braided PVC hose and suction probes to further meet the industrial needs and requirements. The DX12 is also a great complement to the DX2.5 in automotive applications due to its larger size and ability to handle warm fluids up to 80°C (176°F), i.e. engine oil exchange.











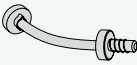

	Part no.	Description	Canister volume	Diameter	Height	Suction hose	Temperature range	Weight
<b>DX2.5</b>	12 016 1001	Comes equipped with PVC hose fitted with a universal bleed adapter, a suction probe and an evacuation hose.	2.5 l (2.6 qts)	175 mm (6.9")	280 mm (11.0")	2.7 m (8.8 ft)	-20°C to +60°C (-4°F to +140°F)	2.0 kg (4.4 lb)
<b>DX12</b>	12 016 5001	Comes equipped with a braided PVC hose featuring a CEJN 320 Soft-Line coupling and two suction probes (Ø 5x1000 mm + Ø 8x1000 mm).	12 l (12.7 qts)	250 mm (9.8")	530 mm (20.9")	1.5 m (4.9 ft)	-20°C to +80°C (-4°F to +176°F)	4.4 kg (9.7 lb)

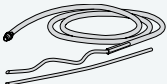
Please check with an authorized CEJN distributor for availability and prices.

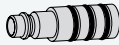
## Accessories

Included in the CEJN DX-range are a wide variety of accessories that enables you to custom make your own DX-system for fluid handling. A refiller bottle offers you an effective, one-operator bleeding process and guards against air being sucked into the brake system. In addition, you can dock the refiller bottle to the DX-canister, providing optimum fluid storage. An extension hose is available to provide you with easy access to hard-to-reach brake fluid reservoirs in newer car models. And tubes in different sizes and lengths give you an even more flexible system.



			Part no.	Description
<b>DX2.5</b>	<b>REFILLER ACCESSORY KIT</b>		12 016 2400	Includes a refiller bottle that facilitates an effective, one-operator bleeding process. Eliminates the need to check fluid levels in the brake fluid reservoir during the bleeding process and guards against air being sucked into the brake system.
<b>DX2.5</b>	<b>HOSE EXTENSION</b>		12 016 2450	Helps to get at hard-to-reach brake fluid reservoirs in compact engine spaces such as on minivans.
<b>DX2.5</b>	<b>AUTO ACCESSORY KIT</b>		12 016 2200	Includes a refiller bottle, bleeding hose, and round top for normal brake bleeding and clutch/reverse bleeding in confined areas.
<b>DX2.5</b>	<b>FLUID ACCESSORY KIT</b>		12 016 2100	Includes a suction hose and two suction tubes (one bendable and one flexible) for fluid evacuation.
<b>DX2.5</b>	<b>MC ACCESSORY KIT</b>		12 016 2300	Includes a refiller bottle, bleeding hose, and reservoir adapters that fit most motorbikes, plus a Y-hose for use on twin-caliper systems.
<b>DX12</b>	<b>DIPSTICK TUBE ADAPTER</b>		12 015 7011 12 016 2000	For use on Mercedes vehicles. For use on Jaguar/Ford vehicles.
<b>DX12</b>	<b>TUBE</b>		12 015 7015	Bendable tube—Ø 8-mm, length 800 mm.
<b>DX12</b>	<b>TUBE</b>		12 015 1945	Flexible tube—Ø 8-mm, length 1500 mm.
<b>DX12</b>	<b>TUBE</b>		12 015 1985	Bendable tube—Ø 12-mm, length 550 mm.
<b>DX12</b>	<b>TUBE</b>		12 015 1947	Flexible tube—Ø 6-mm, length 2000 mm.
<b>DX12</b>	<b>TUBE</b>		12 015 1942	Flexible tube—Ø 6-mm, length 1000 mm.

Please check with an authorized CEJN distributor for availability and prices.



*Your Global*  
**Quick Connect Partner**

