



DIRECTIONAL CONTROL NAMUR VALVES 95 & 34 SERIES

PRODUCT CATALOG



NAMUR Interface Valves 95 Series

Product Overview

The ROSS® NAMUR Interface 95 Series are directional control valves, assembled according to the standard interface for actuator mountings.

These valves stand out for their solid, compact construction, high flow capacity, and fast response time.



Illustration examples.

VALVE FEATURES

| | |
|-----------------------|---|
| Spool Design | Resilient seal spool construction |
| Mounting | NAMUR Interface; Standard actuator interface according VDI/VDE384 |
| Construction | Solid compact construction with high flow capacity |
| Reliability | Consistent fast response times over the life of the valve |
| Solenoid Pilot | Solenoid and connector included |

| Actuation | Valve Function | Inlet Port Size | Maximum Flow C _v (NI/min) | Page | |
|-------------------------|----------------|-----------------|---|------------|-------|
| | | 1/4 | | | |
| Solenoid Control | 5/2 | Single Solenoid | ● | 1.3 (1300) | 3 – 5 |
| | | Double Solenoid | ● | | |
| Accessories – Silencers | | | | 10 | |

STANDARD SPECIFICATIONS

| | | | | | |
|--|---------------------------|-------------------------|----------------------------------|---------------------------|-----------------------------------|
| GENERAL | Function | | 5/2 Valve | | |
| | Construction Design | | Spool | | |
| | Actuation | | Electrical | Solenoid Pilot Controlled | |
| | Mounting | Type | NAMUR Interface | | |
| | | Orientation | Any, preferably vertical | | |
| | Connection | | Threaded | NPT | G |
| Manual Override | Solenoid Pilot Controlled | Pushbutton, non-locking | | | |
| OPERATING CONDITIONS | Temperature | | Ambient | 41° to 140°F (5° to 60°C) | |
| | | | Media | | |
| | Flow Media | | Filtered air | | |
| | Operating Pressure | | 22.5 to 150 psig (1.5 to 10 bar) | | |
| Pilot Supply | | Internal | | | |
| ELECTRICAL DATA FOR SOLENOID PILOT VALVES | Solenoids | | Current Flow | Operating Voltage | Power Consumption (each solenoid) |
| | | | DC | 24 volts | 2.5 watts |
| | | | AC | 110 volts, 50/60 Hz | 5.5 VA holding |
| | | | Rated for continuous duty | | |
| | Enclosure Rating | | IP 65, IEC 60529 | | |
| Electrical Connection | | EN 175301-803 Form B | | | |
| CONSTRUCTION MATERIAL | Valve Body | | Bar Stock Aluminum | | |
| | Poppet | | Stainless Steel | | |
| | Seals | | Buna-N | | |

IMPORTANT NOTE: Please read carefully and thoroughly all of the CAUTIONS, WARNINGS on the inside back cover.

95 Series Solenoid Pilot Controlled Valves

DIMENSIONS

Inches (mm)

Single Solenoid Valve

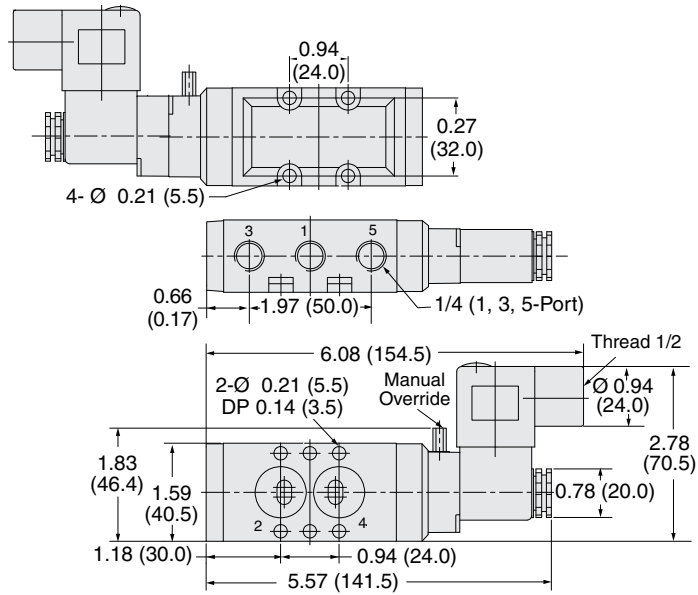

Double Solenoid Valve

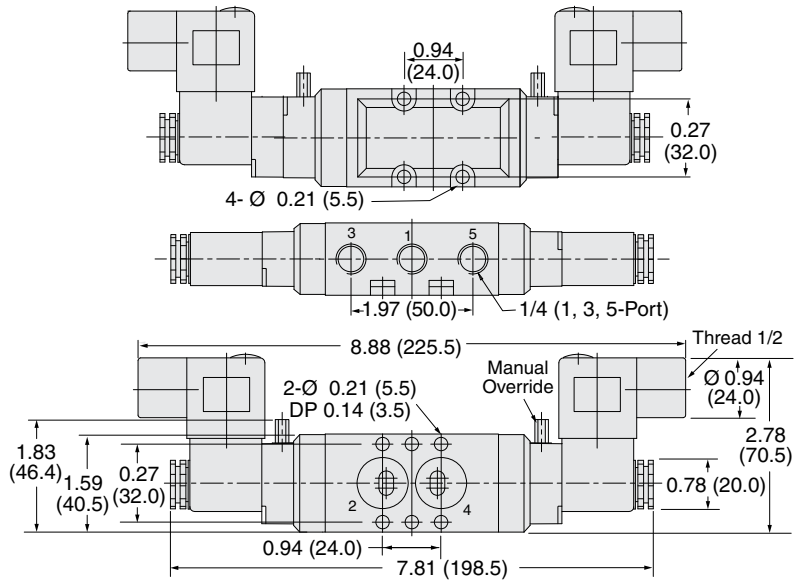

Downloadable CAD models available.

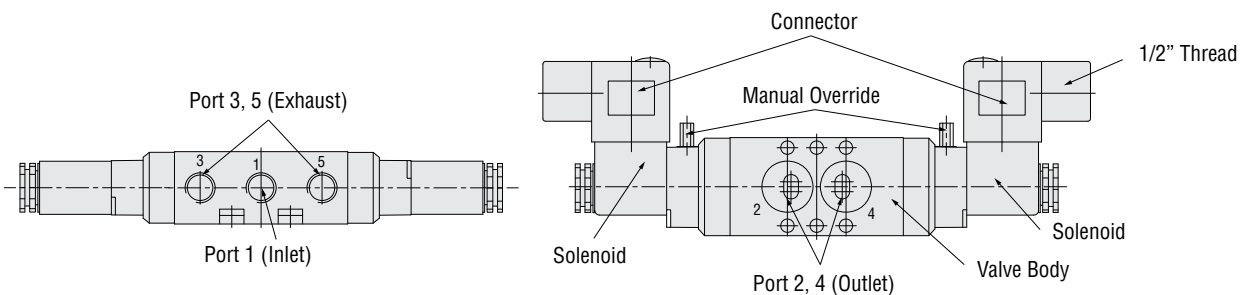

NAMUR Interface Washdown Valves 34 Series

Product Overview

The ROSS® NAMUR Interface 34 Series are directional control valves, assembled according to the standard interface for actuator mountings.

These valves stand out for their solid, compact construction, high flow capacity, and fast response time.

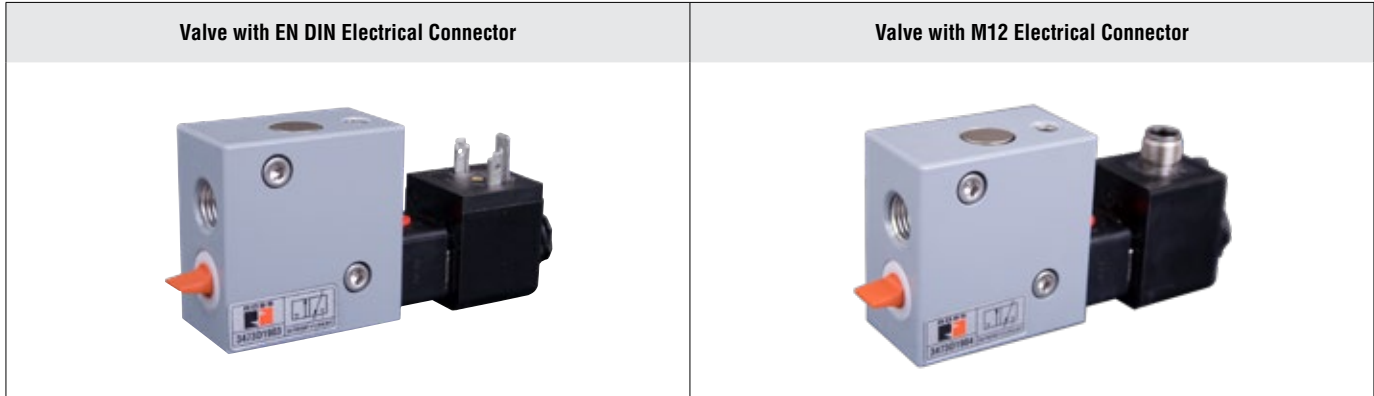
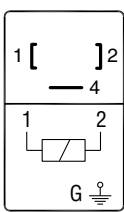
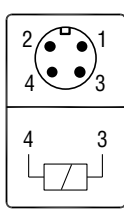

Illustration examples.

VALVE FEATURES

| | |
|--|---|
| Ball-Poppet Design | Patented Ball-poppet internals; Faster and more precise operation than a spool valve |
| Mounting | NAMUR Interface; Standard actuator interface according VDI/VDE384 |
| Construction | Corrosion resistant epoxy powder coat |
| Solenoid Pilot | Solenoid Pilot – Low wattage, fast shifting, repeatable, long life |
| “Duck-bill” Protected Exhaust Port(s) | Limits wash down fluids from entering the valve; Minimizes the collection point for contamination |
| Reliability | Near zero internal leakage for the life of the valve, self cleaning valve seats, sure shifting |

Solenoid Pinouts

| | DIN EN 175301-803 Form A | M12 |
|-----------------|---|---|
| Solenoid |  <p>1 - Positive 2 - Negative 4 - Ground</p> |  <p>3 - Positive 4 - Negative</p> |

| Actuation | Valve Function | Inlet Port Size | Maximum Flow C _v (NI/min) | Page |
|--------------------------|----------------|-----------------|---|------|
| | | 1/4 | | |
| Solenoid Control | 3/2 | ● | 1.3 (1300) | 7– 9 |
| | 5/2 | ● | | |
| Accessories – Connectors | | | | 10 |

STANDARD SPECIFICATIONS

| | | | | | |
|--|--|-------------------------|-----------------------------|----------------------------|--------------------------------------|
| GENERAL | Function | | 3/2 Valve | | |
| | | | 5/2 Valve | | |
| | Construction Design | | Ball-Poppet | | |
| | Actuation | | Electrical | Solenoid Pilot Controlled | |
| | Mounting | Type | NAMUR Interface | | |
| | | Orientation | Any, preferably vertical | | |
| | Connection | | Threaded | NPT | |
| Manual Override | Solenoid Pilot Controlled | Pushbutton, non-locking | | | |
| OPERATING CONDITIONS | Temperature | | Ambient | 4° to 122°F (-10° to 50°C) | |
| | | | Media | | |
| | <i>For temperatures below 40°F (4°C) air must be free of water vapor to prevent formation of ice.</i> | | | | |
| | Flow Media | | Filtered air | | |
| | Operating Pressure | | 29 to 116 psig (2 to 8 bar) | | |
| Pilot Supply | | Internal | | | |
| ELECTRICAL DATA FOR SOLENOID PILOT VALVES | Solenoids | | Current Flow | Operating Voltage | Power Consumption (each solenoid) |
| | | | DC | 24 volts | 0.7 watts |
| | | | AC | 110 volts, 50/60 Hz | 5.8 watts nominal, 6.5 watts maximum |
| | Rated for continuous duty | | | | |
| | Enclosure Rating | | IP 65, IEC 60529 | | |
| Electrical Connection | | EN 175301-803 Form A | | | |
| | | M12 | | | |
| CONSTRUCTION MATERIAL | Valve Body | | Bar Stock Aluminum | | |
| | Poppet | | Stainless Steel | | |
| | Seals | | Buna-N | | |
| STANDARD | NEMA 4X (enclosure constructed for indoor or outdoor use to provide a degree of protection to personnel against incidental contact with the enclosed equipment; and also provides protection in highly corrosive environments. | | | | |

IMPORTANT NOTE: Please read carefully and thoroughly all of the CAUTIONS, WARNINGS on the inside back cover.

Ordering Information

34 Series 3/2 Solenoid Pilot Controlled Valves

MODEL NUMBER CONFIGURATOR

3-Way 2-Position Valves

| | 34 | 7 | 3 | D | 1 | 9 | 04 | W | | | | | | | | | | |
|---|---------------------|----------|----------|----------|----------|----------|-----------|----------|--|-----------------------|---------|-----|----------------------|------|----|-----|---------------------|----|
| Series | | | | | | | | | | | | | | | | | | |
| Actuation | | | | | | | | | | | | | | | | | | |
| Solenoid Pilot | | | | | | | | | | | | | | | | | | |
| Valve Function | | | | | | | | | | | | | | | | | | |
| 3/2 Normally Closed | | | | | | | | | | | | | | | | | | |
| Revision Level | | | | | | | | | | | | | | | | | | |
| | | | | | | | | | <table border="1"> <thead> <tr> <th>Current</th> <th>Voltage</th> <th></th> </tr> </thead> <tbody> <tr> <td>DC</td> <td>24 V</td> <td>W</td> </tr> <tr> <td>AC</td> <td>110-120 V, 50/60 Hz</td> <td>Z</td> </tr> </tbody> </table> | Current | Voltage | | DC | 24 V | W | AC | 110-120 V, 50/60 Hz | Z |
| Current | Voltage | | | | | | | | | | | | | | | | | |
| DC | 24 V | W | | | | | | | | | | | | | | | | |
| AC | 110-120 V, 50/60 Hz | Z | | | | | | | | | | | | | | | | |
| | | | | | | | | | <table border="1"> <thead> <tr> <th colspan="2">Electrical Connection</th> <th></th> </tr> </thead> <tbody> <tr> <td>EN 175301-803 Form A</td> <td></td> <td>00</td> </tr> <tr> <td>M12</td> <td></td> <td>04</td> </tr> </tbody> </table> | Electrical Connection | | | EN 175301-803 Form A | | 00 | M12 | | 04 |
| Electrical Connection | | | | | | | | | | | | | | | | | | |
| EN 175301-803 Form A | | 00 | | | | | | | | | | | | | | | | |
| M12 | | 04 | | | | | | | | | | | | | | | | |
| | | | | | | | | | <table border="1"> <thead> <tr> <th colspan="2">Port Size</th> </tr> </thead> <tbody> <tr> <td colspan="2">1/4</td> </tr> </tbody> </table> | Port Size | | 1/4 | | | | | | |
| Port Size | | | | | | | | | | | | | | | | | | |
| 1/4 | | | | | | | | | | | | | | | | | | |
| <p>Model Number examples: 3473D1904W, 3473D1900W.</p> <p>For other voltages, consult ROSS.</p> <p>Note: 10-24 and M5 mounting fasteners available upon request.</p> | | | | | | | | | | | | | | | | | | |

34 Series 5/2 Solenoid Pilot Controlled Valves

MODEL NUMBER CONFIGURATOR

5-Way 2-Position Valves

| | 34 | 7 | 6 | C | 1 | 9 | 00 | W | | | | | | | | | | |
|---|---------------------|----------|----------|----------|----------|----------|-----------|----------|--|-----------------------|---------|-----|----------------------|------|----|-----|---------------------|----|
| Series | | | | | | | | | | | | | | | | | | |
| Actuation | | | | | | | | | | | | | | | | | | |
| Solenoid Pilot | | | | | | | | | | | | | | | | | | |
| Valve Function | | | | | | | | | | | | | | | | | | |
| 5/2 | | | | | | | | | | | | | | | | | | |
| Revision Level | | | | | | | | | | | | | | | | | | |
| | | | | | | | | | <table border="1"> <thead> <tr> <th>Current</th> <th>Voltage</th> <th></th> </tr> </thead> <tbody> <tr> <td>DC</td> <td>24 V</td> <td>W</td> </tr> <tr> <td>AC</td> <td>110-120 V, 50/60 Hz</td> <td>Z</td> </tr> </tbody> </table> | Current | Voltage | | DC | 24 V | W | AC | 110-120 V, 50/60 Hz | Z |
| Current | Voltage | | | | | | | | | | | | | | | | | |
| DC | 24 V | W | | | | | | | | | | | | | | | | |
| AC | 110-120 V, 50/60 Hz | Z | | | | | | | | | | | | | | | | |
| | | | | | | | | | <table border="1"> <thead> <tr> <th colspan="2">Electrical Connection</th> <th></th> </tr> </thead> <tbody> <tr> <td>EN 175301-803 Form A</td> <td></td> <td>00</td> </tr> <tr> <td>M12</td> <td></td> <td>04</td> </tr> </tbody> </table> | Electrical Connection | | | EN 175301-803 Form A | | 00 | M12 | | 04 |
| Electrical Connection | | | | | | | | | | | | | | | | | | |
| EN 175301-803 Form A | | 00 | | | | | | | | | | | | | | | | |
| M12 | | 04 | | | | | | | | | | | | | | | | |
| | | | | | | | | | <table border="1"> <thead> <tr> <th colspan="2">Port Size</th> </tr> </thead> <tbody> <tr> <td colspan="2">1/4</td> </tr> </tbody> </table> | Port Size | | 1/4 | | | | | | |
| Port Size | | | | | | | | | | | | | | | | | | |
| 1/4 | | | | | | | | | | | | | | | | | | |
| <p>Model Number examples: 3476C1904W, 3476C1900W.</p> <p>For other voltages, consult ROSS.</p> <p>Note: 10-24 and M5 mounting fasteners available upon request.</p> | | | | | | | | | | | | | | | | | | |

Valve Schematics

3/2 Valve

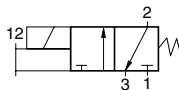

5/2 Valve

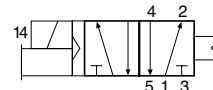

95 Series Solenoid Pilot Controlled Valves

| Valve Function | Size | Flow C _v (NI/min) | Mounting Bolts | Weight lb (kg) |
|----------------|--------------|---------------------------------|----------------|-------------------|
| | Port 1, 3, 5 | | | |
| 3/2 | 1/4 | 0.25 (250) | 10-32 | 0.8 (0.3) |
| 5/2 | 1/4 | 0.25 (250) | 10-32 | 0.9 (0.4) |

DIMENSIONS

Inches (mm)

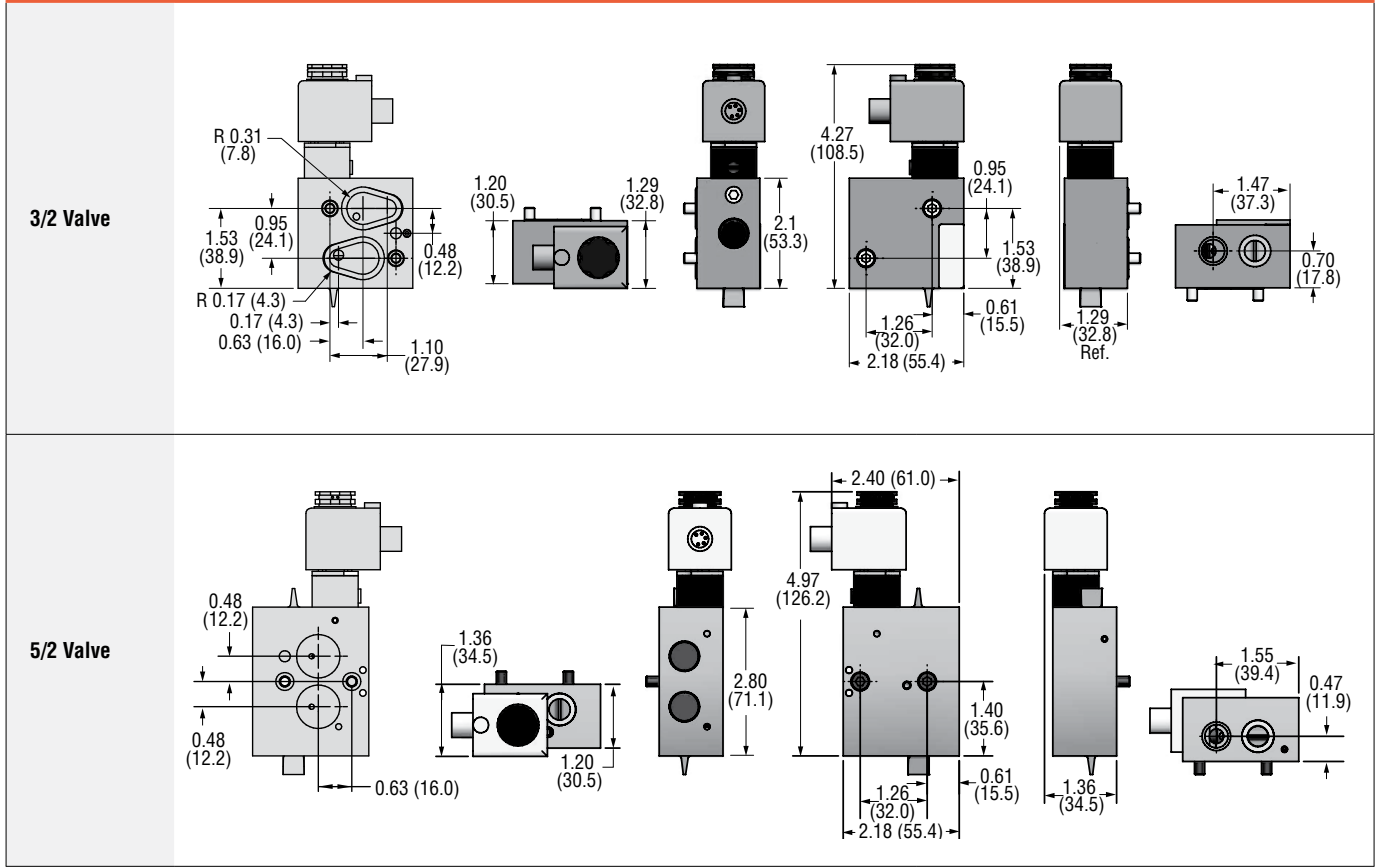

Downloadable CAD models available.

Thread 1/2

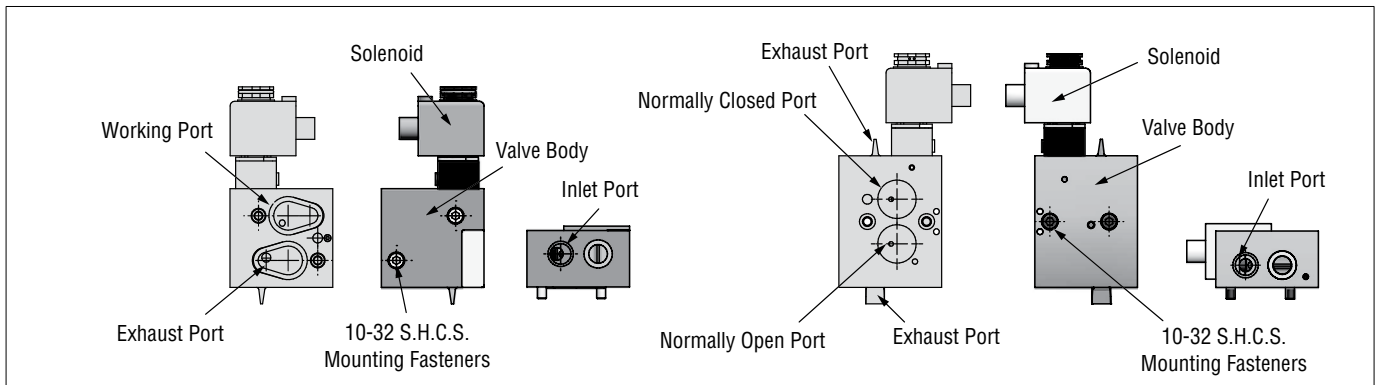

Accessories

EXHAUST SILENCERS (for 95 Series Only)



Illustration example.

| Silencers | SPECIFICATIONS | | Silencer Material | Pressure Range psig (bar) | Schematic | | |
|-----------|----------------|-------------|---------------------------------|------------------------------|-----------|---------------------------|-------------|
| | | | Aluminum | 0-290 (0-20) maximum | | | |
| | Port Size | Thread Type | Flow C _v (NI/min) | Model Number | | Dimensions inches (mm) | |
| 1/4 | Male | 2.3 (2300) | NPT Thread | R/Rp Thread | Length | Hex Size (D) | |
| | | | 5500A2003 | D5500A2003 | 2.2 (6) | 0.81 (21) | 0.07 (0.03) |

ELECTRICAL CONNECTORS (for 34 Series only)

Cable Grip

Without Light



With Light



Illustration examples.

| Connectors | Connector | | | | | Model Number | | | |
|-----------------------------|---------------|------------------|--------------------|-------------------|---------------------|---------------|-------------------|----------|----------|
| | Type | Connection | Fitting Connection | Quantity Included | Cord Diameter mm | Without Light | Lighted Connector | | |
| | | | | | | | 24 V DC | 120 V AC | 230 V AC |
| DIN EN 175301-803 Form A | Solenoid | Cable grip | 1 | 8 to 10 | 937K87 | 936K87-W | 936K87-Z | 936K87-Y | |
| | | 1/2" NPT conduit | 1 | - | 723K77 | 724K77-W | 724K77-Z | 724K77-Y | |
| M12 | Consult ROSS. | | | | | | | | |

Connector Pinouts

Solenoid

DIN EN 175301-803

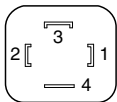

- 1 - Black
- 2 - Black
- 4 - Green/Yellow (Ground)

M12

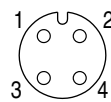

- 1 - Normally Closed
- 2 - Normally Closed
- 3 - Blue (Negative)
- 4 - Brown (Positive)

CAUTIONS, WARNINGS And STANDARD WARRANTY



ROSS OPERATING VALVE, ROSS CONTROLS®, ROSS DECCO®, and AUTOMATIC VALVE INDUSTRIAL, collectively the “ROSS Group”.

PRE-INSTALLATION or SERVICE

1. Before servicing a valve or other pneumatic component, be sure all sources of energy are turned off, the entire pneumatic system is shut down and exhausted, and all power sources are locked out (ref: OSHA 1910.147, EN 1037).
2. All ROSS Group Products, including service kits and parts, should be installed and/or serviced only by persons having training and experience with pneumatic equipment. Because any product can be tampered with and/or need servicing after installation, persons responsible for the safety of others or the care of equipment must check ROSS Group Products on a regular basis and perform all necessary maintenance to ensure safe operating conditions.
3. All applicable instructions should be read and complied with before using any fluid power system to prevent harm to persons or equipment. In addition, overhauled or serviced valves must be functionally tested prior to installation and use. If you have any questions, call your nearest ROSS Group location.
4. Each ROSS Group Product should be used within its specification limits. In addition, use only ROSS Group components to repair ROSS Group Products.

WARNINGS:

Failure to follow these instructions can result in personal injury and/or property damage.

FILTRATION and LUBRICATION

1. Dirt, scale, moisture, etc., are present in virtually every air system. Although some valves are more tolerant of these contaminants than others, best performance will be realized if a filter is installed to clean the air supply, thus preventing contaminants from interfering with the proper performance of the equipment. The ROSS Group recommends a filter with a 5-micron rating for normal applications.
2. All standard ROSS Group filters and lubricators with polycarbonate plastic bowls are designed for compressed air applications only. Use the metal bowl guard, where provided, to minimize danger from high pressure fragmentation in the event of bowl failure. Do not expose these products to certain fluids, such as alcohol or liquefied petroleum gas, as they can cause bowls to rupture, creating a combustible condition and hazardous leakage. Immediately replace crazed, cracked, or deteriorated bowls.
3. Only use lubricants which are compatible with materials used in the valves and other components in the system. Normally, compatible lubricants are petroleum base oils with oxidation inhibitors, an aniline point between 180°F (82°C) and 220°F (104°C), and an ISO 32, or lighter, viscosity. Avoid oils with

phosphate type additives which can harm polyurethane components, potentially leading to valve failure which risks personal injury, and/or damage to property.

WARNINGS:

Failure to follow these instructions can result in personal injury and/or property damage.

AVOID INTAKE/EXHAUST RESTRICTION

1. Do not restrict air flow in the supply line. To do so could reduce the pressure of the supply air below minimum requirements for the valve and thereby causing erratic action.
2. Do not restrict a valve's exhaust port as this can adversely affect its operation. Exhaust silencers must be resistant to clogging and must have flow capacities at least as great as the exhaust capacities of the valves. Contamination of the silencer can result in reduced flow and increased back pressure.

WARNINGS: Failure to follow these instructions can result in personal injury and/or property damage.

SAFETY APPLICATIONS

1. Mechanical Power Presses and other potentially hazardous machinery using a pneumatically controlled clutch and brake mechanism must use a press control double valve with a monitoring device. A double valve without a self-contained monitoring device should be used only in conjunction with a control system which assures monitoring of the valve. All double valve installations involving hazardous applications should incorporate a monitoring system which inhibits further operation of the valve and machine in the event of a failure within the valve mechanism.
2. Safe Exhaust (dump) valves without a self-contained monitoring device should be used only in conjunction with a control system which assures monitoring of the valve. All Safe Exhaust valve installations should incorporate a monitoring system which inhibits further operation of the valve and machine in the event of a failure within the valve mechanism.
3. Per specifications and regulations, the ROSS L-O-X® and L-O-X® with EEZ-ON®, N06 and N16 Series operation products are defined as energy isolation devices, NOT AS EMERGENCY STOP DEVICES.

WARNINGS:

Failure to follow these instructions can result in personal injury and/or property damage.

STANDARD WARRANTY

All products sold by the ROSS Group are warranted for a one-year period [with the exception of Filters, Regulators and Lubricators (“FRLs”) which are warranted for a period of seven (7) years] from the date of purchase. All products are, during their respective warranty periods, warranted to be free of defects in material and workmanship. The ROSS Group's obligation under this warranty is limited to repair, replacement or refund of the purchase price paid for products which the ROSS Group has determined, in its sole discretion, are defective. All warranties become void if a product has been subject to misuse, misapplication, improper maintenance, modification or tampering. Products for which warranty protection is sought must be returned to the ROSS Group freight prepaid.

THE WARRANTY EXPRESSED ABOVE IS IN LIEU OF AND EXCLUSIVE OF ALL OTHER WARRANTIES AND THE ROSS GROUP EXPRESSLY DISCLAIMS ALL OTHER WARRANTIES EITHER EXPRESSED OR IMPLIED WITH RESPECT TO MERCHANTABILITY OR FITNESS FOR A PARTICULAR PURPOSE. THE ROSS GROUP MAKES NO WARRANTY WITH RESPECT TO ITS PRODUCTS MEETING THE PROVISIONS OF ANY GOVERNMENTAL OCCUPATIONAL SAFETY AND/OR HEALTH LAWS OR REGULATIONS. IN NO EVENT IS THE ROSS GROUP LIABLE TO PURCHASER, USER, THEIR EMPLOYEES OR OTHERS FOR INCIDENTAL OR CONSEQUENTIAL DAMAGES WHICH MAY RESULT FROM A BREACH OF THE WARRANTY DESCRIBED ABOVE OR THE USE OR MISUSE OF THE PRODUCTS. NO STATEMENT OF ANY REPRESENTATIVE OR EMPLOYEE OF THE ROSS GROUP MAY EXTEND THE LIABILITY OF THE ROSS GROUP AS SET FORTH HEREIN.



| | | | | |
|---------------------------|---------------------------------------|----------------|---------------------------|--|
| AMERICAS | ROSS CONTROLS | USA | Tel: +1-248-764-1800 | www.rosscontrols.com |
| | ROSS CONTROLS CANADA Ltd. | Canada | Tel: +1-416-251-7677 | www.rosscanada.com |
| | ROSS DO BRASIL LTDA | Brazil | Tel: +55-11-4335-2200 | www.rosscontrols.com.br |
| EUROPE | ROSS EUROPA GmbH | Germany | Tel: +49 (0)6103-7597-100 | www.rosseuropa.com |
| | ROSS FRANCE SAS | France | Tel: +33-(0)1-49-45-65-65 | www.rossfrance.com |
| | ROSS PNEUMATROL Ltd. | United Kingdom | Tel: +44 (0)1254 872277 | www.rossuk.co.uk |
| ASIA & PACIFIC | ROSS CONTROLS INDIA Pvt. Ltd. | India | Tel: +91-44-2624-9040 | www.rosscontrolsindia.com |
| | ROSS CONTROLS (CHINA) Ltd. | China | Tel: +86-21-6915-7961 | www.rosscontrolschina.com |
| | ROSS ASIA K.K. | Japan | Tel: +81-42-778-7251 | www.rossasia.co.jp |
| | AUTOMATIC VALVE INDUSTRIAL LLC | USA | Tel: +1-248-474-6700 | www.automaticvalve.com |
| | ROSS DECCO COMPANY | USA | Tel: +1-248-764-1800 | www.rossdecco.com |
| | ROSS PNEUMATROL Ltd. | United Kingdom | Tel: +44 (0)1254 872277 | www.pneumatrol.com |
| | manufactIS GmbH | Germany | Tel: +49 (0)2013-16843-0 | www.manufactis.net |

Full-Service Global Locations

There are ROSS Distributors Throughout the World

To meet your requirements across the globe, ROSS distributors are located throughout the world. Through ROSS or its distributors, guidance is available for the selection of ROSS products, both for those using fluid power components for the first time and those designing complex systems.

Other literature is available for engineering, maintenance, and service requirements.

If you need products or specifications not shown in this catalog, please visit ROSS' website, contact ROSS or your ROSS distributor. The ROSS Support Team will be happy to assist you in selecting the best product for your application.