



DIRECTIONAL CONTROL SLIM-LINE VALVES 95 SERIES

PRODUCT CATALOG



Slim-Line Valves 95 Series

Product Overview

The ROSS® 95 Series are body-ported directional control valves, inline or manifold mounted with a durable seal design, for lube or non-lube service.

These valves stand out for their solid, compact construction and high flow capacity.



Illustration examples.

VALVE FEATURES

Spool Design	Resilient seal spool construction
Mounting Options	Flexible mounting - inline or manifold
Construction	Solid compact construction with high flow capacity
Reliability	Consistent response times over the life of the valve
Solenoid Pilot Valves	Solenoid and connector included

Actuation	Valve Function		Available Inlet Port Sizes				Maximum Flow C _v (NI/min)	Page
			1/8	1/4	3/8	1/2		
Solenoid Control	3/2	Single Solenoid Pilot	●	●	●		2.6 (2600)	4 – 5
	5/2	Single & Double Solenoid Pilot	●	●	●	●	4.5 (4400)	6 – 9
	5/3	Double Solenoid Pilot	●	●	●	●	4.5 (4400)	10 – 11
Pressure Control	3/2	Single Air Pilot	●	●	●		2.6 (2600)	12 – 13
	5/2	Single & Double Air Pilot	●	●	●	●	4.5 (4400)	14 – 17
	5/3	Double Air Pilot	●	●	●	●	4.5 (4400)	18 – 19
Sub-Bases & Manifold Bases								20 – 21
Accessories								22

STANDARD SPECIFICATIONS

GENERAL	Function		3/2 Valve	Normally Closed		
					Normally Open	
			5/2 Valve			
			5/3 Valve	Center Position	Power Center	
					Closed Center	
					Open Center	
	Construction Design		Spool			
	Actuation		Electrical	Solenoid Pilot Controlled		
			Pneumatic	Pressure Controlled		
	Mounting	Type	Inline or manifold mounted			
Orientation		Any, preferably vertical				
Connection		Threaded	NPT			
			G			
Manual Override	Solenoid Pilot Controlled	Pushbutton, non-locking				
OPERATING CONDITIONS	Temperature		Ambient	41° to 140°F (5° to 60°C)		
			Media			
	Flow Media		Filtered air			
	Operating Pressure		22.5 to 150 psig (1.5 to 10 bar)			
Pilot Supply		Internal				
ELECTRICAL DATA FOR SOLENOID PILOT VALVES	Solenoids		Current Flow	Operating Voltage	Power Consumption (each solenoid)	
			DC	24 volts	2.5 watts	
			AC	110 volts, 50/60 Hz	3.6 VA holding on 50/60 Hz	
			Rated for continuous duty			
	Enclosure Rating		IP 65, IEC 60529			
Electrical Connection		Port Size	1/8	EN 175301-803 MICRO-MINI connector		
			1/4 & 3/8	EN 175301-803 Industrial Form B connector		
CONSTRUCTION MATERIAL	Valve Body		Bar Stock Aluminum			
	Poppet		Stainless Steel			
	Seals		Buna-N			

IMPORTANT NOTE: Please read carefully and thoroughly all of the CAUTIONS, WARNINGS on the inside back cover.

Ordering Information

3/2 Single Solenoid Pilot Controlled Valves, Spring Return

MODEL NUMBER CONFIGURATOR

3-Way 2-Position Valves

95 7 3 K 1 0 01 W

Port Thread	
NPT	
Leave Blank	
G	D

Series: 95

Actuation: Solenoid Pilot

Valve Function	
3/2 Normally Closed	3
3/2 Normally Open	4

Revision Level: 1

Current	Voltage	
DC	24 V	W
AC	110-120 V, 50/60 Hz	Z

Solenoid Pilot: Single Solenoid

Port Size		
In-Out	Exhaust	
1/8	1/8	1
1/4	1/4	2
3/8	3/8	3

Model Number examples: 9573K1001W, D9573K3001Z.

Manifolds and accessories ordered separately. Please see manifolds and accessories page. For other options, consult ROSS.

Valves available with installed prewired connectors, please consult ROSS.

Size		Flow C _v (NI/min)	Weight lb (kg)
Port 1, 2	Port 3		
1/8	1/8	1-2 0.9 (980)	0.38 (0.17)
1/4	1/4	1.3 (1300)	0.70 (0.32)
3/8	3/8	2.6 (2600)	1.15 (0.52)

Valve Schematics

Normally Closed

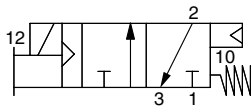

Normally Open

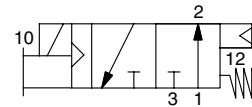

Flow Charts

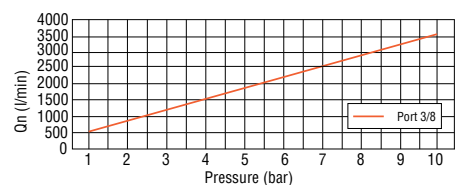
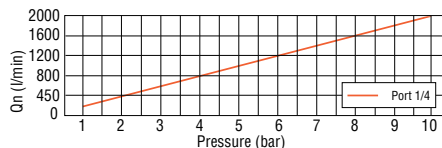
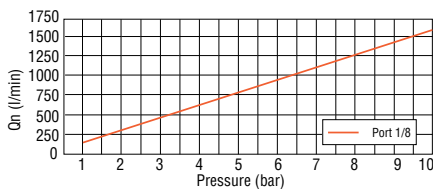

3/2 Single Solenoid Pilot Controlled Valves

DIMENSIONS

Inches (mm)

Port Size 1/8

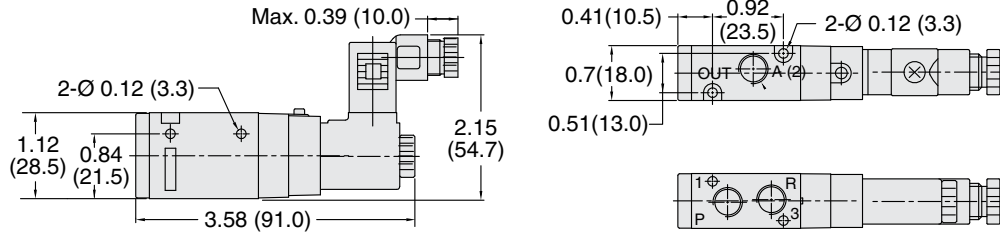

Port Size 1/4

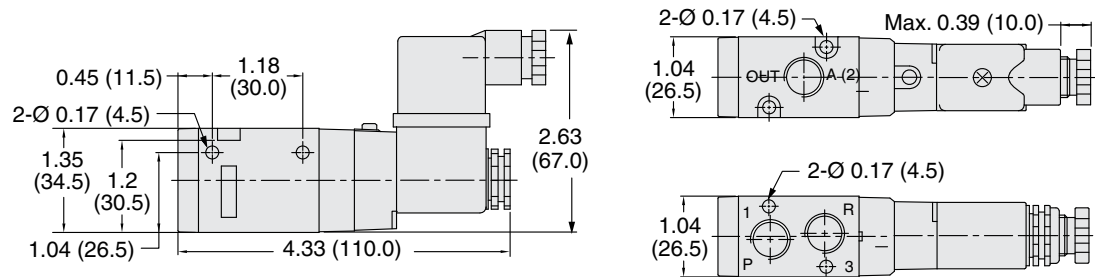

Port Size 3/8

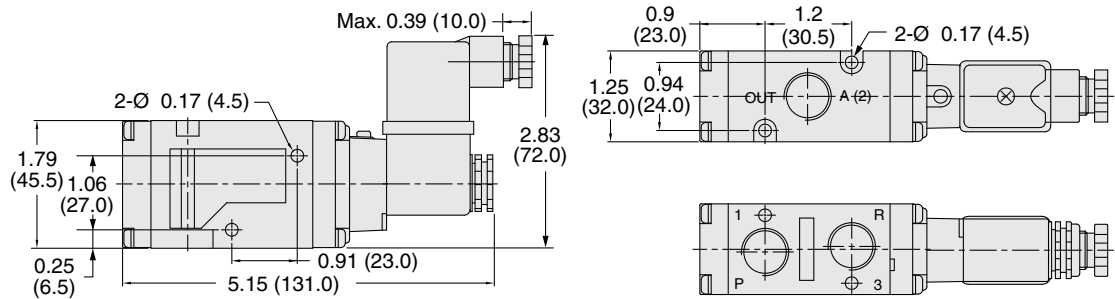

Downloadable CAD models available.

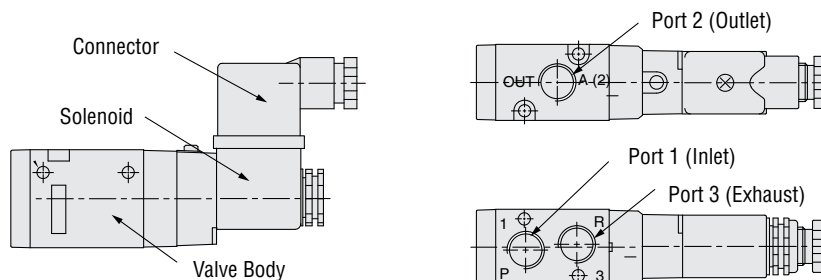

Ordering Information

5/2 Single Solenoid Pilot Controlled Valves, Spring Return

MODEL NUMBER CONFIGURATOR

5-Way 2-Position Valves

	95	7	6	K	1	0	01	W
--	-----------	----------	----------	----------	----------	----------	-----------	----------

Port Thread	
NPT	
Leave Blank	
G	D

Series	
--------	--

Actuation	Solenoid Pilot
-----------	----------------

Valve Function	5/2
----------------	-----

Revision Level	
----------------	--

Current	Voltage	
DC	24 V	W
AC	110-120 V, 50/60 Hz	Z

Solenoid Pilot	Single Solenoid
----------------	-----------------

Port Size		
In-Out	Exhaust	
1/8	1/8	1
1/4	1/4	2
3/8	3/8	3
1/2	1/2	4

Model Number examples: 9576K1001W, D9576K4001Z.

Manifolds and accessories ordered separately. Please see manifolds and accessories page. For other options, consult ROSS.

Valves available with installed prewired connectors, please consult ROSS.

Size		Flow C _v (NI/min)	Weight lb (kg)
Port 1, 2, 4	Port 3, 5	1-2, 1-4	
1/8	1/8	0.9 (980)	0.43 (0.20)
1/4	1/4	1.3 (1300)	0.80 (0.36)
3/8	3/8	2.6 (2600)	1.29 (0.59)
1/2	1/2	4.5 (4400)	1.66 (0.75)

Valve Schematic

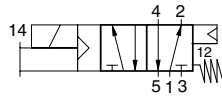

Flow Charts

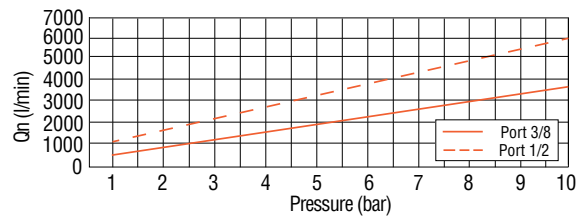
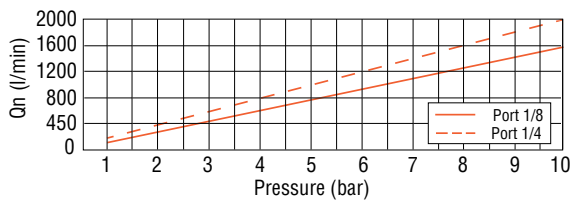

5/2 Single Solenoid Pilot Controlled Valves

DIMENSIONS

Inches (mm)

<p>Port Size 1/8</p>		
<p>Port Size 1/4</p>		
<p>Port Size 3/8</p>		
<p>Port Size 1/2</p>		

Downloadable CAD models available.

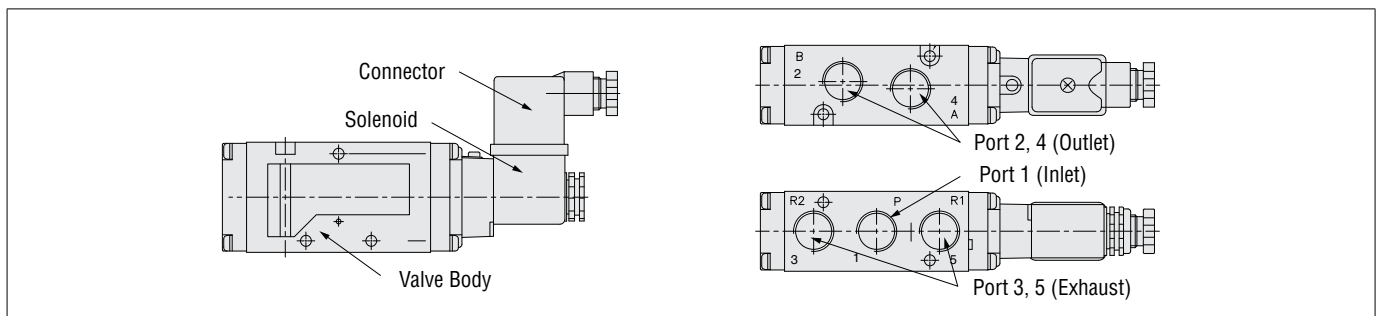

Ordering Information

5/2 Double Solenoid Pilot Controlled Valves, Detented

MODEL NUMBER CONFIGURATOR

5-Way 2-Position Valves

95 7 6 K 1 0 02 W

Port Thread	
NPT	
Leave Blank	
G	D

Series: 95

Actuation: Solenoid Pilot

Valve Function: 5/2

Revision Level: K

Current	Voltage	
DC	24 V	W
AC	110-120 V, 50/60 Hz	Z

Solenoid Pilot: Double Solenoid

Port Size		
In-Out	Exhaust	
1/8	1/8	1
1/4	1/4	2
3/8	3/8	3
1/2	1/2	4

Model Number examples: 95761002W, D9576K4002Z.

Manifolds and accessories ordered separately. Please see manifolds and accessories page. For other options, consult ROSS.

Valves available with installed prewired connectors, please consult ROSS.

Size		Flow C _v (NI/min)	Weight lb (kg)
Port 1, 2, 4	Port 3, 5	1-2, 1-4	
1/8	1/8	0.9 (980)	0.62 (0.28)
1/4	1/4	1.3 (1300)	1.04 (0.47)
3/8	3/8	2.6 (2600)	1.58 (0.72)
1/2	1/2	4.5 (4400)	2.04 (0.93)

Valve Schematic

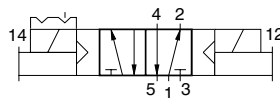

Flow Charts

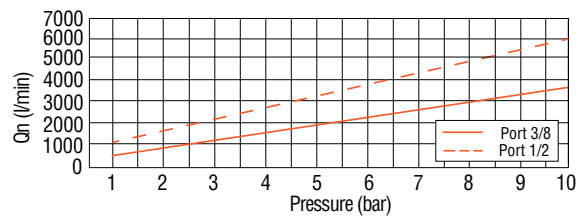
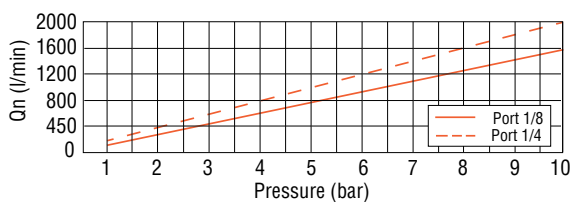

5/2 Double Solenoid Pilot Controlled Valves

DIMENSIONS

Inches (mm)

Port Size 1/8

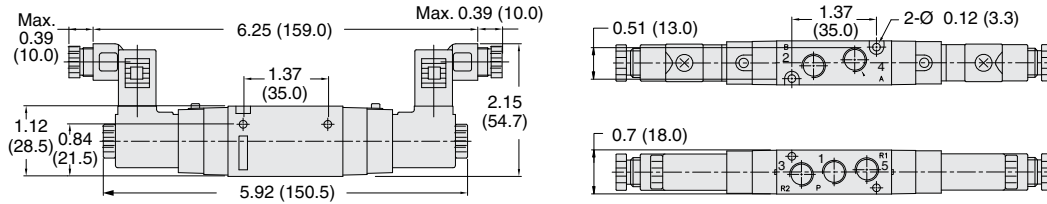

Port Size 1/4

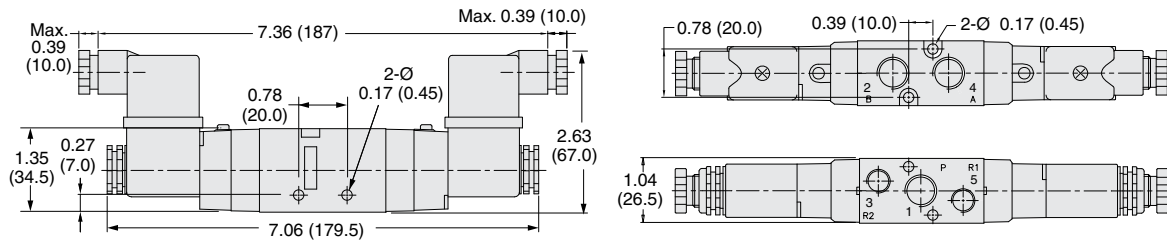

Port Size 3/4

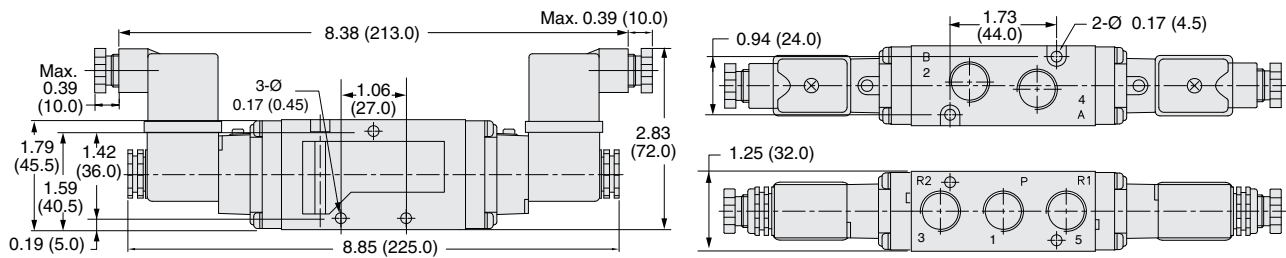

Port Size 1/2

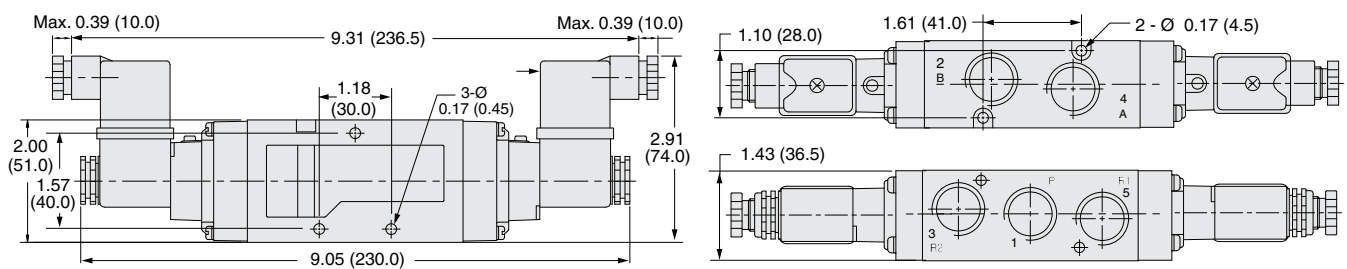

Downloadable CAD models available.

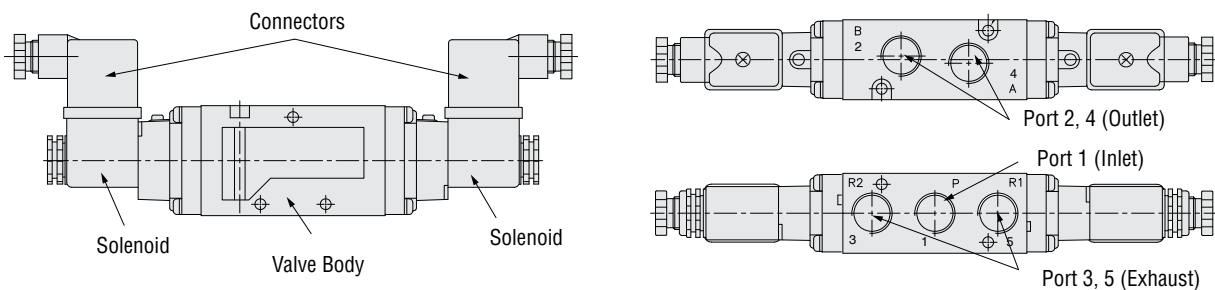

Ordering Information

5/3 Double Solenoid Pilot Controlled Valves, Spring Center

MODEL NUMBER CONFIGURATOR

5-Way 3-Position Valves

95 7 7 K 1 0 19 W

Port Thread			
NPT			
Leave Blank			
G	D		

Series	
95	

Actuation	
Solenoid Pilot	7

Valve Function	
5/3	7

Revision Level	
	K

Current	Voltage	
DC	24 V	W
AC	110-120 V, 50/60 Hz	Z

Center Position	
Power Center	19
Closed Center	10
Open Center	07

Port Size		
In-Out	Exhaust	
1/8	1/8	1
1/4	1/4	2
3/8	3/8	3
1/2	1/2	4

Model Number examples: 95771019W, D9577K4010Z.

Manifolds and accessories ordered separately. Please see manifolds and accessories page. For other options, consult ROSS.

Valves available with installed prewired connectors, please consult ROSS.

Size		Flow C _v (NL/min)	Weight lb (kg)
Port 1, 2, 4	Port 3, 5	1-2, 1-4	
1/8	1/8	0.7 (69)	0.70 (0.32)
1/4	1/4	1.1 (1100)	1.26 (0.57)
3/8	3/8	2.2 (2200)	1.71 (0.78)
1/2	1/2	4.5 (4400)	2.41 (1.09)

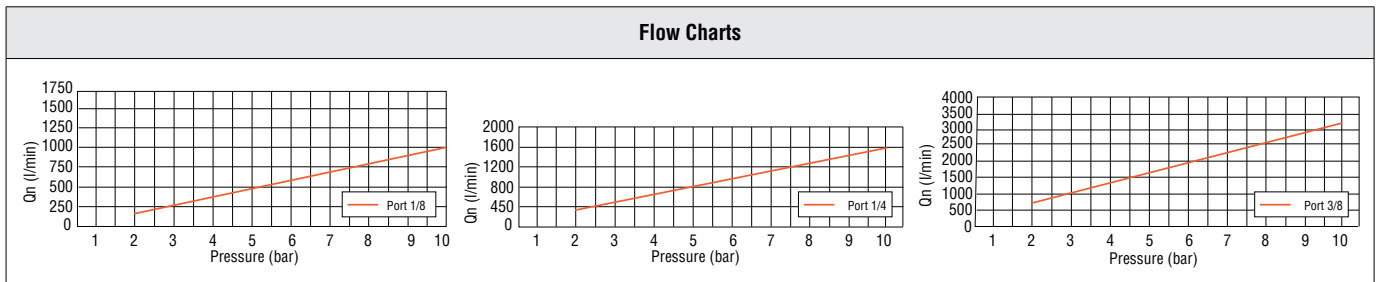
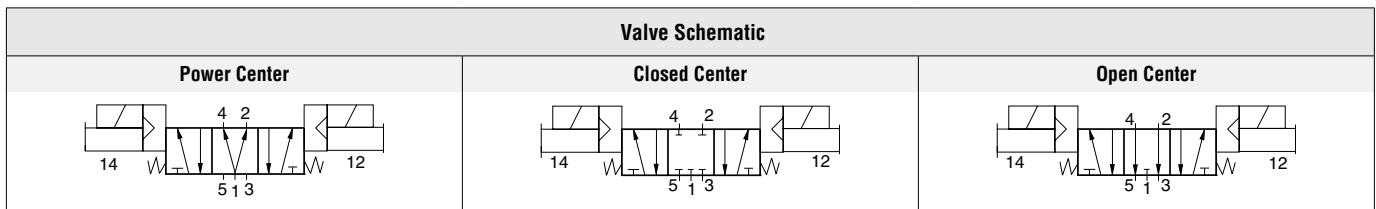

5/3 Double Solenoid Pilot Controlled Valves

DIMENSIONS

Inches (mm)

Port Size 1/8

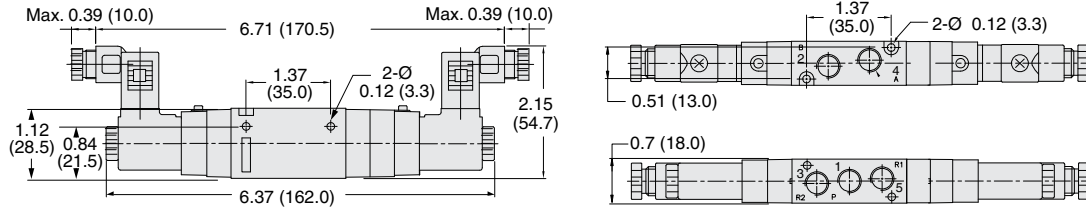

Port Size 1/4

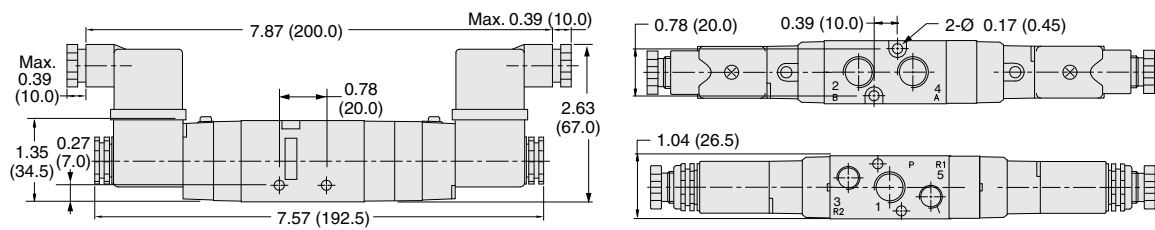

Port Size 3/4

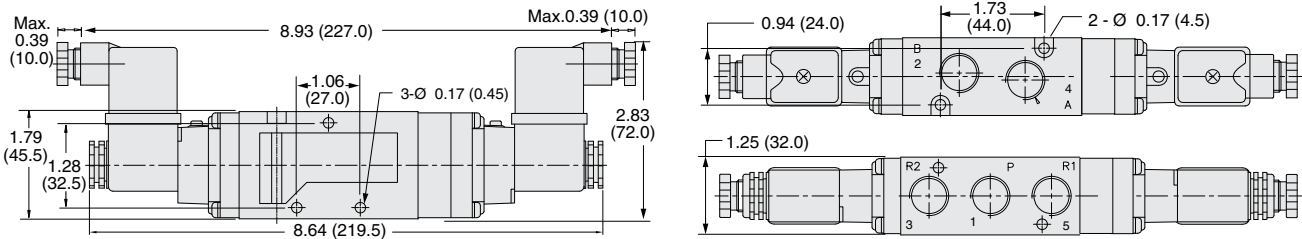

Port Size 1/2

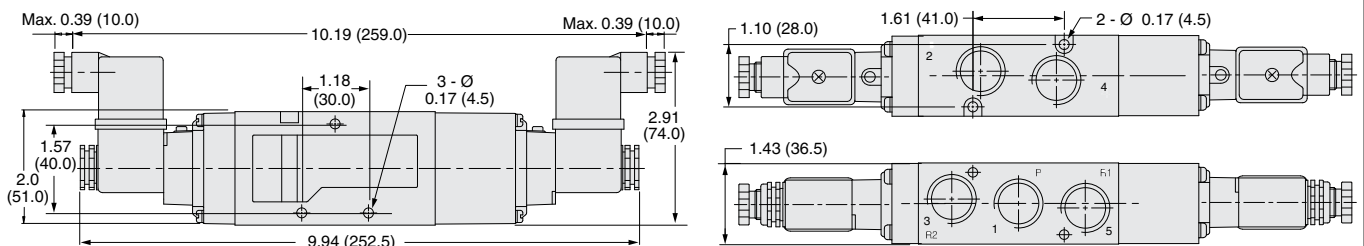

Downloadable CAD models available.

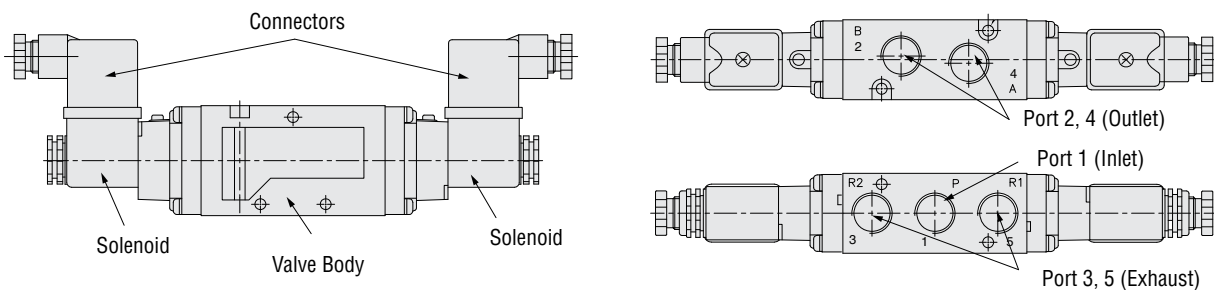

Ordering Information

3/2 Single Pilot Pressure Controlled Valves, Spring Return

MODEL NUMBER CONFIGURATOR

3-Way 2-Position Valves

95 5 3 K 1 0 00

Port Thread	
NPT	
Leave Blank	
G	D

Series

Actuation

Pressure Controlled

Valve Function	
3/2 Normally Closed	3
3/2 Normally Open	4

Air Pilot

Single Pilot

Port Size			
In-Out	Exhaust	Signal Port Thread	
1/8	1/8	10-32 UNF	1
1/4	1/4	1/8	2
3/8	3/8	1/8	3

Revision Level

Model Number examples: 9553K1000, D9553K3000.

Manifolds and accessories ordered separately. Please see manifolds and accessories page. For other options, consult ROSS.

Size		Flow C_v (NI/min)	Weight lb (kg)
Port 1, 2	Port 3	1-2	
1/8	1/8	0.9 (980)	0.26 (0.12)
1/4	1/4	1.3 (1300)	0.51 (0.23)
3/8	3/8	2.6 (2600)	0.86 (0.39)

Valve Schematics

Normally Closed

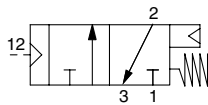

Normally Open

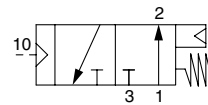

Flow Charts

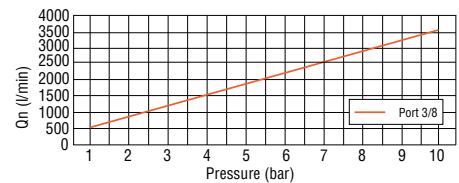
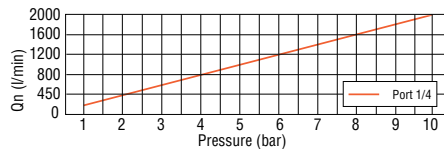
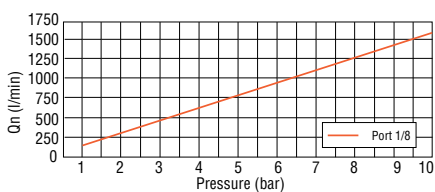

3/2 Single Pilot Pressure Controlled Valves, Spring Return

DIMENSIONS

Inches (mm)

<p>Port Size 1/8</p>		
<p>Port Size 1/4</p>		
<p>Port Size 3/8</p>		

Downloadable CAD models available.

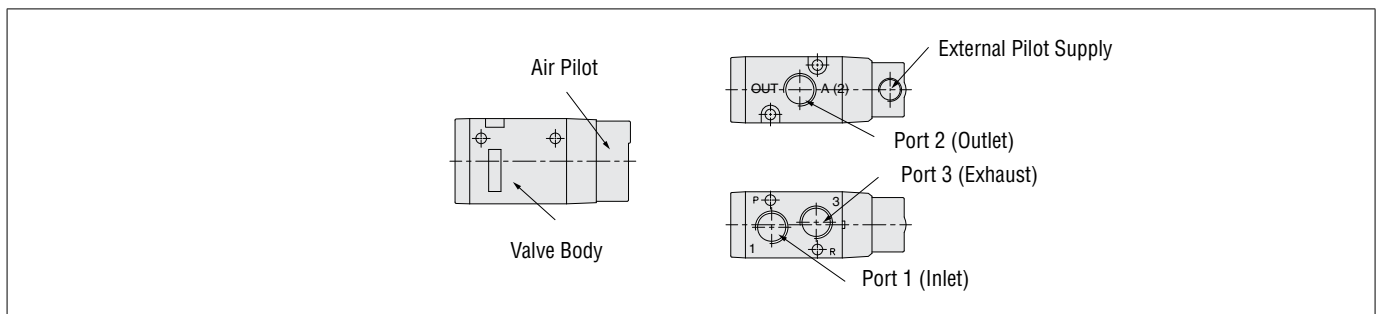

Ordering Information

5/2 Single Pilot Pressure Controlled Valves, Spring Return

MODEL NUMBER CONFIGURATOR

5-Way 2-Position Valves

95 5 6 K 1 0 01

Port Thread	
NPT	
Leave Blank	
G	D

Series

Actuation

Pressure Controlled

Valve Function

5/2

Air Pilot

Single Pilot

Port Size			
In-Out	Exhaust	Signal Port Thread	
1/8	1/8	1/8	1
1/4	1/4	1/8	2
3/8	3/8	1/8	3
1/2	1/2	1/8	4

Revision Level

Model Number examples: 9556K1001, D9556K3001.

Manifolds and accessories ordered separately. Please see manifolds and accessories page. For other options, consult ROSS.

Size		Flow C _v (NI/min)	Weight lb (kg)
Port 1, 2, 4	Port 3, 5	1-2, 1-4	
1/8	1/8	0.9 (890)	0.26 (0.12)
1/4	1/4	1.3 (1300)	0.48 (0.22)
3/8	3/8	2.6 (2600)	1.02 (0.46)
1/2	1/2	4.5 (4400)	1.39 (0.63)

Valve Schematic

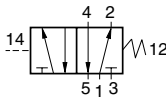

Flow Charts

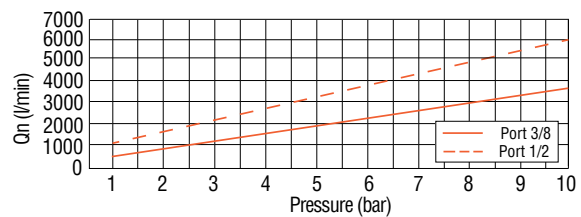
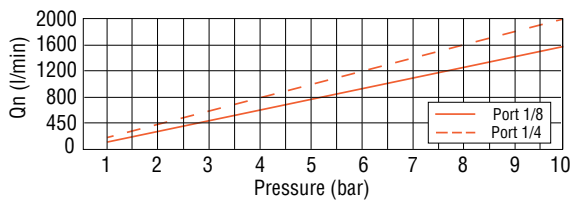

5/2 Single Pilot Pressure Controlled Valves, Spring Return

DIMENSIONS

Inches (mm)

Port Size 1/8

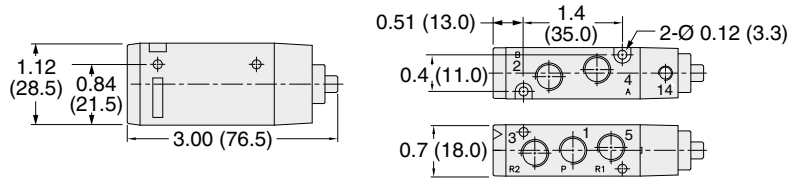

Port Size 1/4

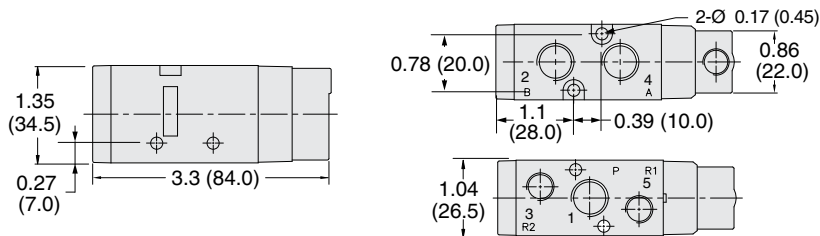

Port Size 3/4

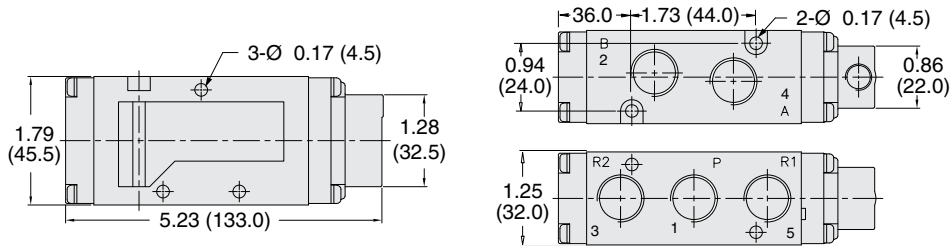

Port Size 1/2

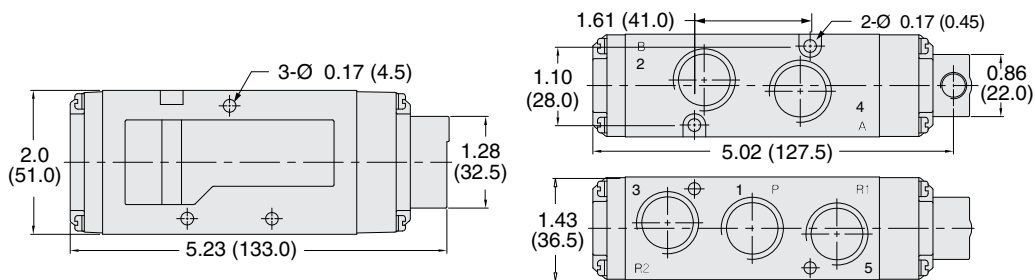

Downloadable CAD models available.

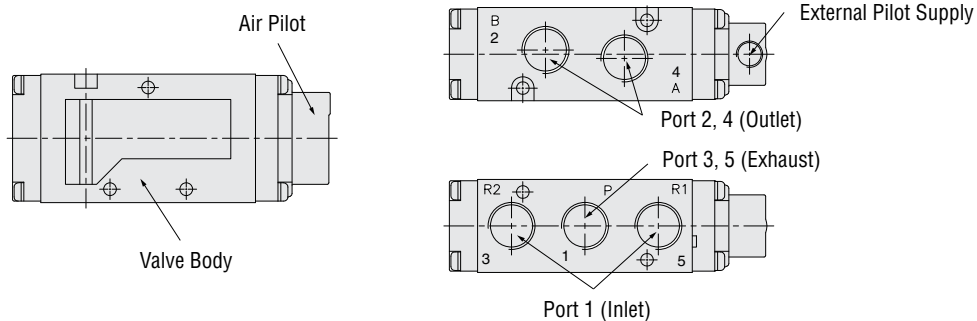

Ordering Information

5/2 Double Pilot Pressure Controlled Valves, Detented

MODEL NUMBER CONFIGURATOR

5-Way 2-Position Valves

Port Thread									
NPT									
Leave Blank									
G									
Series		95	5	6	K	1	0	02	
Actuation									Air Pilot
Pressure Controlled									Double Pilot
Valve Function									
5/2									

Port Size			
In-Out	Exhaust	Signal Port Thread	
1/8	1/8	1/8	1
1/4	1/4	1/8	2
3/8	3/8	1/8	3
1/2	1/2	1/8	4

Revision Level	

Model Number examples: 9556K1002, D9556K3004.

Manifolds and accessories ordered separately. Please see manifolds and accessories page. For other options, consult ROSS.

Size		Flow Cv (NI/min)	Weight lb (kg)
Port 1, 2, 4	Port 3, 5	1-2, 1-4	
1/8	1/8	0.9 (89)	0.32 (0.15)
1/4	1/4	1.3 (1300)	0.59 (0.27)
3/8	3/8	2.6 (2600)	1.07 (0.49)
1/2	1/2	4.5 (4400)	1.55 (0.70)

Valve Schematic

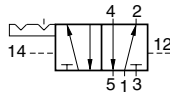

Flow Charts

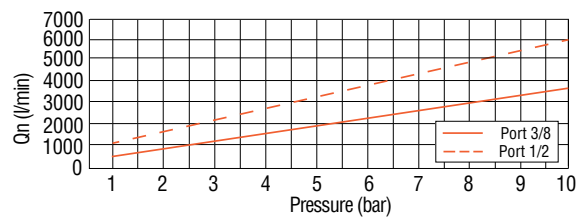
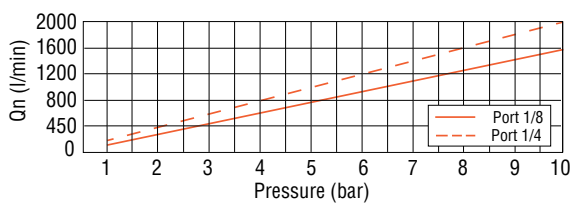

5/2 Double Pilot Pressure Controlled Valves, Detented

DIMENSIONS

Inches (mm)

Port Size 1/8

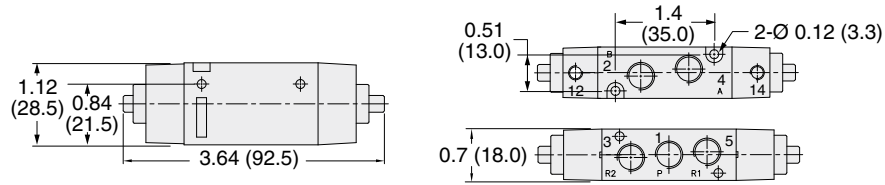

Port Size 1/4

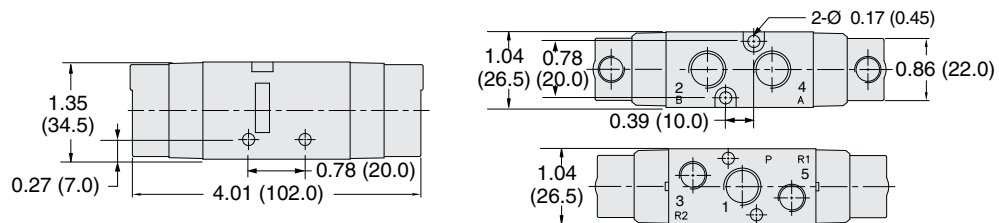

Port Size 3/4

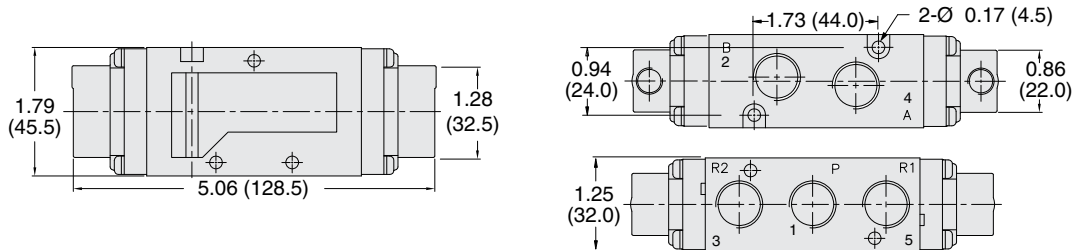

Port Size 1/2

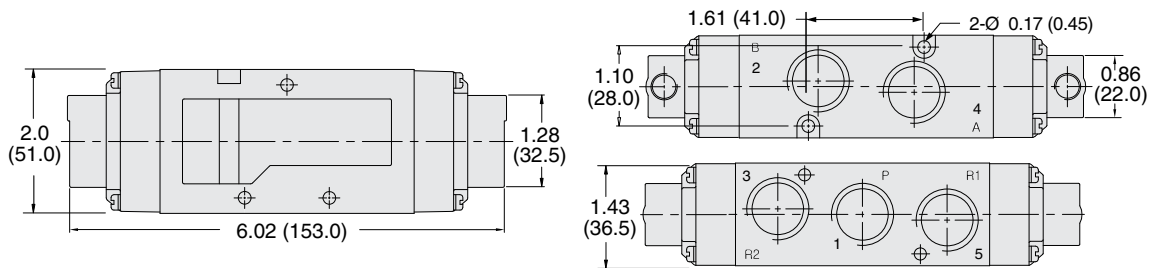

Downloadable CAD models available.

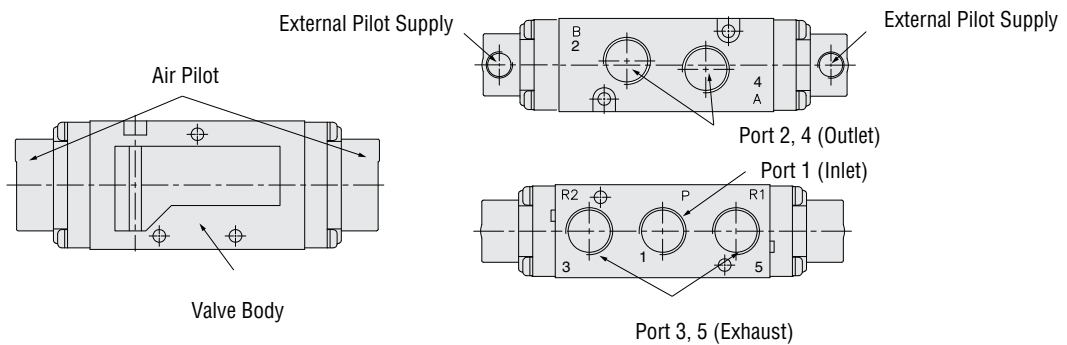

Ordering Information

5/3 Double Pilot Pressure Controlled Valves, Spring Center

MODEL NUMBER CONFIGURATOR

5-Way 3-Position Valves

	95	5	7	K	1	0	19																								
<table border="1" style="width: 100%; border-collapse: collapse;"> <tr><td>Port Thread</td><td></td></tr> <tr><td>NPT</td><td></td></tr> <tr><td>Leave Blank</td><td></td></tr> <tr><td>G</td><td>D</td></tr> </table>	Port Thread		NPT		Leave Blank		G	D																							
Port Thread																															
NPT																															
Leave Blank																															
G	D																														
<table border="1" style="width: 100%; border-collapse: collapse;"> <tr><td>Series</td><td></td></tr> </table>	Series																														
Series																															
<table border="1" style="width: 100%; border-collapse: collapse;"> <tr><td>Actuation</td><td></td></tr> <tr><td>Pressure Controlled</td><td></td></tr> </table>	Actuation		Pressure Controlled																												
Actuation																															
Pressure Controlled																															
<table border="1" style="width: 100%; border-collapse: collapse;"> <tr><td>Valve Function</td><td></td></tr> <tr><td>5/3</td><td></td></tr> </table>	Valve Function		5/3																												
Valve Function																															
5/3																															
						<table border="1" style="width: 100%; border-collapse: collapse;"> <tr><td>Center Position</td><td></td></tr> <tr><td>Power Center</td><td>19</td></tr> <tr><td>Closed Center</td><td>10</td></tr> <tr><td>Open Center</td><td>07</td></tr> </table>		Center Position		Power Center	19	Closed Center	10	Open Center	07																
Center Position																															
Power Center	19																														
Closed Center	10																														
Open Center	07																														
						<table border="1" style="width: 100%; border-collapse: collapse;"> <tr><td colspan="3">Port Size</td><td></td></tr> <tr><td>In-Out</td><td>Exhaust</td><td>Signal Port Thread</td><td></td></tr> <tr><td>1/8</td><td>1/8</td><td>10-32 UNF</td><td>1</td></tr> <tr><td>1/4</td><td>1/4</td><td>1/8</td><td>2</td></tr> <tr><td>3/8</td><td>3/8</td><td>1/8</td><td>3</td></tr> <tr><td>1/2</td><td>1/2</td><td>1/8</td><td>4</td></tr> </table>		Port Size				In-Out	Exhaust	Signal Port Thread		1/8	1/8	10-32 UNF	1	1/4	1/4	1/8	2	3/8	3/8	1/8	3	1/2	1/2	1/8	4
Port Size																															
In-Out	Exhaust	Signal Port Thread																													
1/8	1/8	10-32 UNF	1																												
1/4	1/4	1/8	2																												
3/8	3/8	1/8	3																												
1/2	1/2	1/8	4																												
						<table border="1" style="width: 100%; border-collapse: collapse;"> <tr><td>Revision Level</td><td></td></tr> </table>		Revision Level																							
Revision Level																															

Model Number examples: 9557K1019, D9557K3007.

Manifolds and accessories ordered separately. Please see manifolds and accessories page. For other options, consult ROSS.

Size		Flow C _v (NI/min)	Weight lb (kg)
Port 1, 2, 4	Port 3, 5	1-2, 1-4	
1/8	1/8	0.7 (69)	0.38 (0.17)
1/4	1/4	1.1 (1100)	0.51 (0.23)
3/8	3/8	2.2 (2200)	1.39 (0.63)
1/2	1/2	3.4 (2900)	1.98 (0.90)

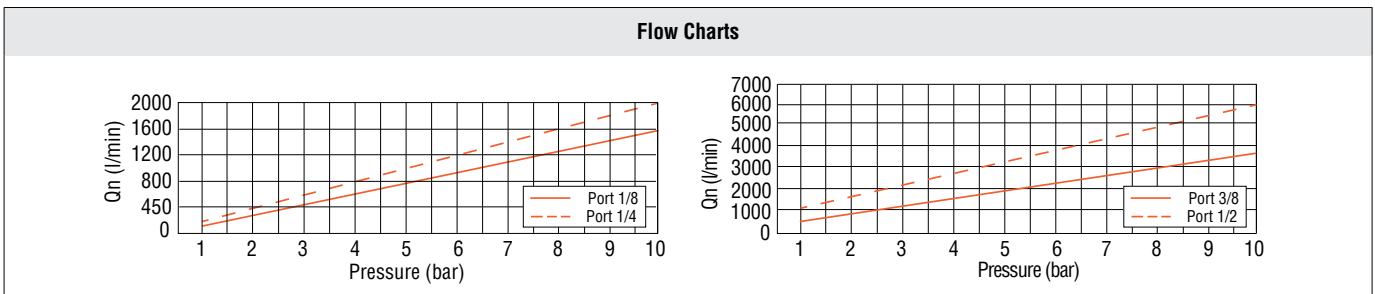
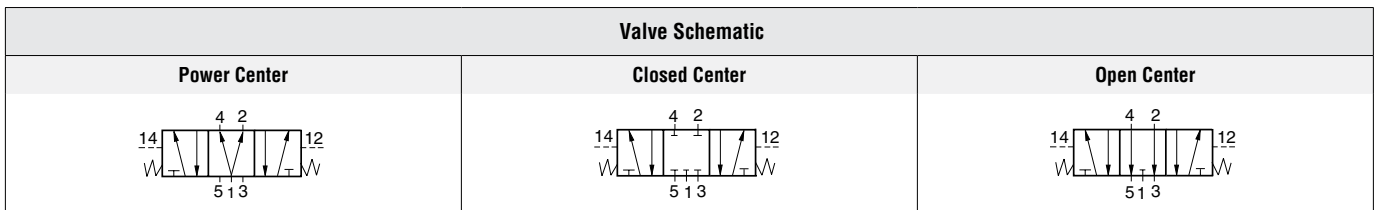

5/3 Double Pilot Pressure Controlled Valves, Spring Center

DIMENSIONS

Inches (mm)

Port Size 1/8

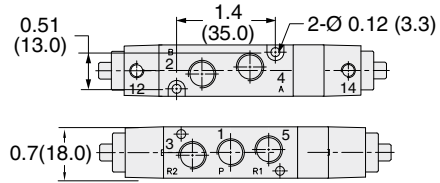
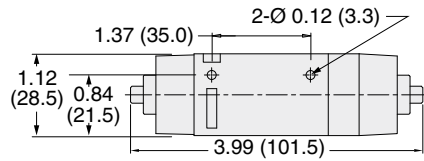

Port Size 1/4

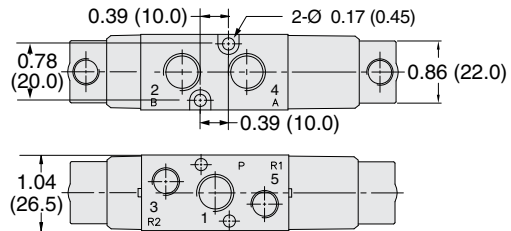
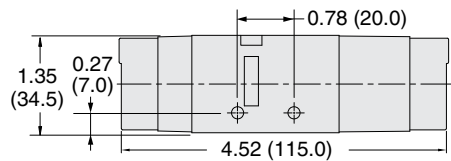

Port Size 3/4

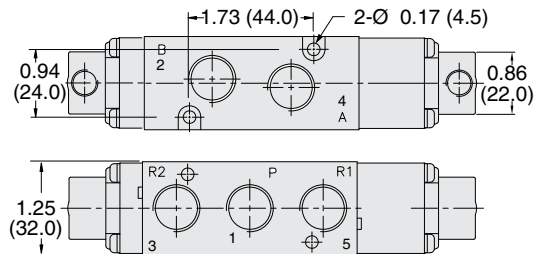
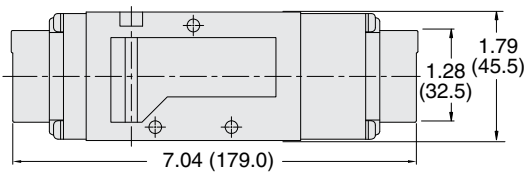

Port Size 1/2

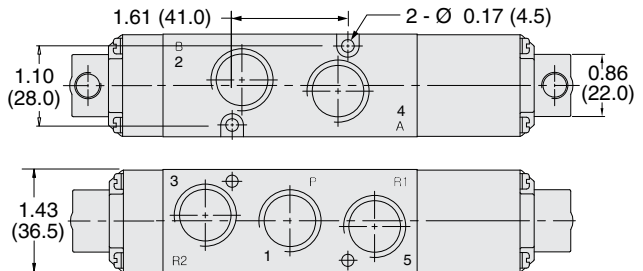
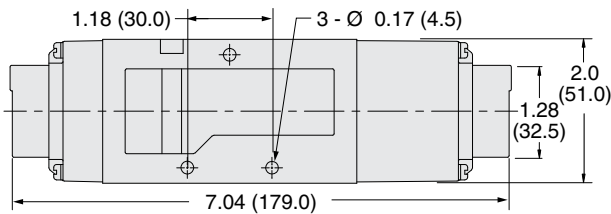

Downloadable CAD models available.

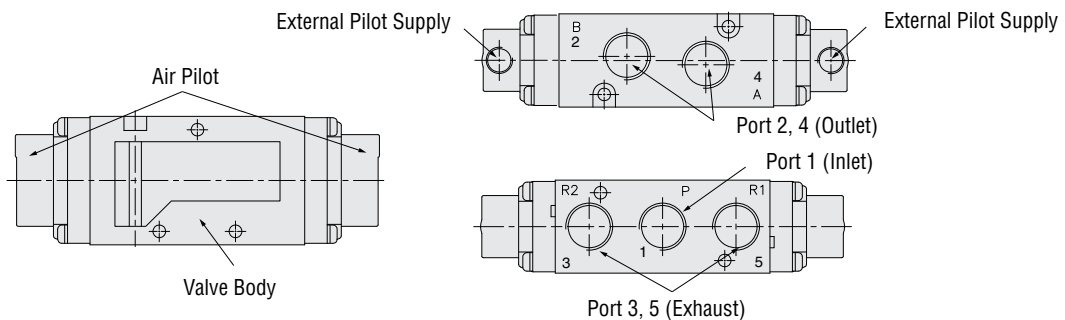

Manifold Bases for 3/2 Valves

MANIFOLD BASES

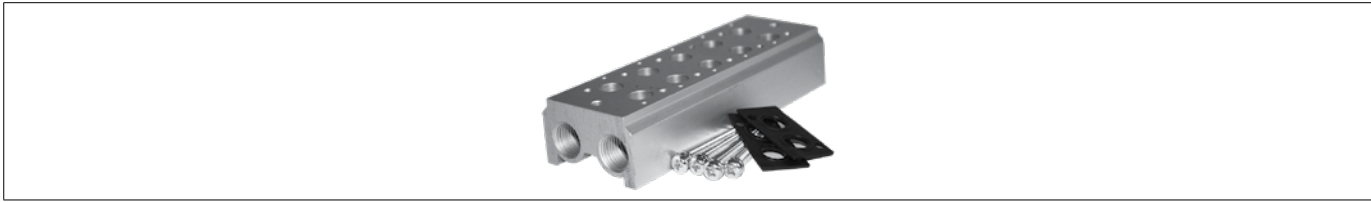
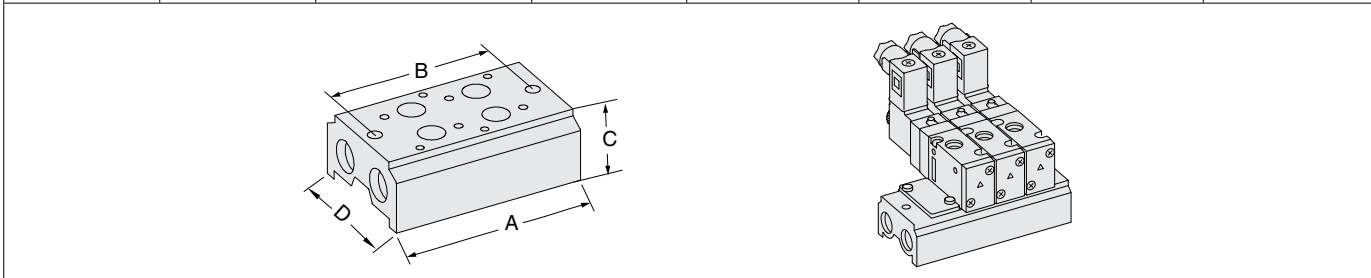

Illustration example.

Port Size		Manifold Model Number									
Valve	Base	2 Valves Unit		4 Valves Unit		6 Valves Unit		8 Valves Unit		10 Valves Unit	
1, 2, 3	1, 3	NPT Thread	G Thread	NPT Thread	G Thread	NPT Thread	G Thread	NPT Thread	G Thread	NPT Thread	G Thread
1/8	1/4	1472H91	D1472H91	1474H91	D1474H91	1476H91	D1476H91	1478H91	D1478H91	1480H91	D1480H91
1/4	1/4	1492H91	D1492H91	1494H91	D1494H91	1496H91	D1496H91	1498H91	D1498H91	1500H91	D1500H91

Port Size		Base Dimensions	Numbers of Valves Unit				
Valve	Base		Dimensions – inches (mm)				
1, 2, 3	1, 3		2	4	6	8	10
1/8	1/4	Height (C)	0.98 (25)	0.98 (25)	0.98 (25)	0.98 (25)	0.98 (25)
		Length (A)	2.32 (59)	3.82 (97)	5.31 (135)	6.81 (173)	8.31 (211)
		Length (B)	1.85 (47)	3.35 (85)	4.84 (123)	6.34 (161)	7.83 (199)
		Width (D)	1.65 (42)	1.65 (42)	1.65 (42)	1.65 (42)	1.65 (42)
1/4	1/4	Height (C)	1.06 (27)	1.06 (27)	1.06 (27)	1.06 (27)	1.06 (27)
		Length (A)	3.03 (77)	5.16 (131)	7.28 (185)	9.41 (239)	11.53 (293)
		Length (B)	2.60 (66)	4.72 (120)	6.85 (174)	8.98 (228)	11.10 (282)
		Width (D)	1.97 (50)	1.97 (50)	1.97 (50)	1.97 (50)	1.97 (50)



MANIFOLD BLANKING KITS



Manifold Gasket

Blanking Plate

Illustration example.

Blanking Kits	Valve Port Size	Kit Number	Description
	1/8	1813H77	Manifold blanking kits include blanking plate, manifold gasket and mounting bolts.
	1/4	1814H77	

MANIFOLD BASES

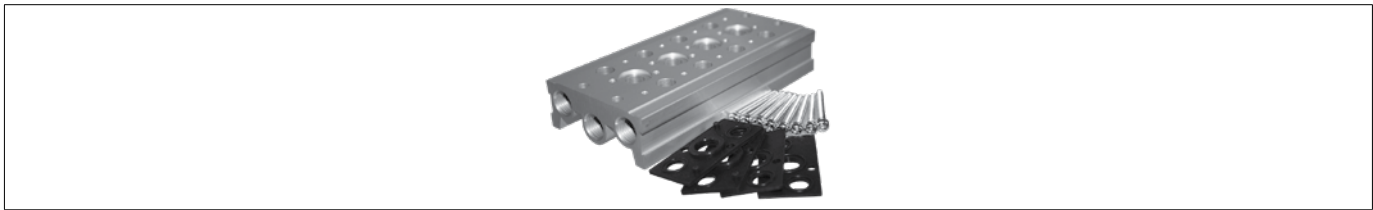

Illustration example.

Port Size			Manifold Model Number									
Valve		Base	2 Valves Unit		4 Valves Unit		6 Valves Unit		8 Valves Unit		10 Valves Unit	
1, 2, 4	3, 5	1, 3, 5	NPT Thread	G Thread	NPT Thread	G Thread	NPT Thread	G Thread	NPT Thread	G Thread	NPT Thread	G Thread
1/8	1/8	1/4	1392H91	D1392H91	1394H91	D1394H91	1396H91	D1396H91	1398H91	D1398H91	1390H91	D1390H91
1/4	1/8	1/4	1412H91	D1412H91	1414H91	D1414H91	1416H91	D1416H91	1418H91	D1418H91	1420H91	D1420H91
3/8	3/8	3/8	1432H91	D1432H91	1434H91	D1434H91	1436H91	D1436H91	1438H91	D1438H91	1440H91	D1440H91
1/2	1/2	1/2	1652H91	D1652H91	1654H91	D1654H91	1656H91	D1656H91	1658H91	D1658H91	1650H91	D1650H91

Port Size			Base Dimensions	Numbers of Valves Unit				
Valve		Base		Dimensions – inches (mm)				
1, 2, 4	3, 5	1, 3, 5		2	4	6	8	10
1/8	1/8	1/4	Height (C)	1.02 (26)	1.02 (26)	1.02 (26)	1.02 (26)	1.02 (26)
			Length (A)	2.32 (59)	3.81 (97)	5.31 (135)	6.81 (173)	8.31 (211)
			Length (B)	1.85 (47)	3.35 (85)	4.84 (123)	6.34 (161)	7.83 (199)
			Width (D)	4.33 (110)	4.33 (110)	4.33 (110)	4.33 (110)	4.33 (110)
1/4	1/8	1/4	Height (C)	1.06 (27)	1.06 (27)	1.06 (27)	1.06 (27)	1.06 (27)
			Length (A)	3.29 (83.5)	5.45 (138.5)	7.62 (193.5)	9.78 (248.5)	11.95 (303.5)
			Length (B)	2.81 (71.5)	4.98 (126.5)	7.15 (181.5)	9.31 (236.5)	7.94 (201.5)
			Width (D)	2.68 (68)	2.68 (68)	2.68 (68)	2.68 (68)	2.68 (68)
3/8	3/8	3/8	Height (C)	1.18 (30)	1.18 (30)	1.18 (30)	1.18 (30)	1.18 (30)
			Length (A)	3.66 (93)	6.26 (159)	8.86 (225)	11.46 (291)	14.05 (357)
			Length (B)	3.15 (80)	5.75 (146)	8.35 (212)	10.94 (278)	13.54 (344)
			Width (D)	3.43 (87)	3.43 (87)	3.43 (87)	3.43 (87)	3.43 (87)
1/2	1/2	1/2	Height (C)	1.32 (33.5)	1.32 (33.5)	1.32 (33.5)	1.32 (33.5)	1.32 (33.5)
			Length (A)	4.05 (103)	7.01 (178)	9.96 (253)	12.91 (328)	15.87 (403)
			Length (B)	3.46 (88)	6.42 (163)	9.37 (238)	12.32 (313)	15.27 (388)
			Width (D)	3.86 (98)	3.86 (98)	3.86 (98)	3.86 (98)	3.86 (98)

MANIFOLD BLANKING KITS

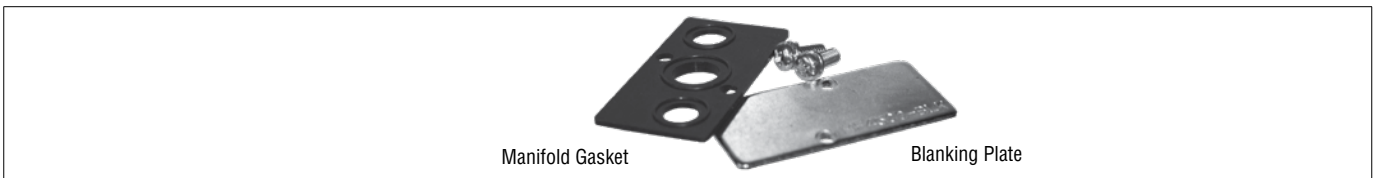

Illustration example.

Blanking Kits	Valve Port Size	Kit Number	Description
	1/8	1813H77	Manifold blanking kits include blanking plate, manifold gasket and mounting bolts.
	1/4	1814H77	
	3/8	1808H77	
	1/2	1809H77	

Accessories

EXHAUST SILENCERS



Illustration example.

Silencers	SPECIFICATIONS		Silencer Material		Pressure Range psig (bar)		Schematic	
			Aluminum		0-290 (0-20) maximum			
	Port Size	Thread Type	Flow C _v (NI/min)	Model Number		Dimensions inches (mm)		Weight lb (kg)
NPT Thread				R/Rp Thread	Length	Hex Size (D)		
1/8	Male	1.3 (1300)	5500A1003	D5500A1003	2.0 (5)	0.81 (21)	0.07 (0.03)	
1/4	Male	2.3 (2300)	5500A2003	D5500A2003	2.2 (6)	0.81 (21)		
3/8	Male	9.0 (8900)	5500A3013	D5500A3013	2.2 (6)	0.81 (21)		
1/2	Male	6.8 (6700)	5500A4003	D5500A4003	3.6 (9)	1.25 (32)	0.2 (0.1)	

CAUTIONS, WARNINGS And STANDARD WARRANTY



ROSS OPERATING VALVE, ROSS CONTROLS®, ROSS DECCO®, and AUTOMATIC VALVE INDUSTRIAL, collectively the “ROSS Group”.

PRE-INSTALLATION or SERVICE

1. Before servicing a valve or other pneumatic component, be sure all sources of energy are turned off, the entire pneumatic system is shut down and exhausted, and all power sources are locked out (ref: OSHA 1910.147, EN 1037).
2. All ROSS Group Products, including service kits and parts, should be installed and/or serviced only by persons having training and experience with pneumatic equipment. Because any product can be tampered with and/or need servicing after installation, persons responsible for the safety of others or the care of equipment must check ROSS Group Products on a regular basis and perform all necessary maintenance to ensure safe operating conditions.
3. All applicable instructions should be read and complied with before using any fluid power system to prevent harm to persons or equipment. In addition, overhauled or serviced valves must be functionally tested prior to installation and use. If you have any questions, call your nearest ROSS Group location.
4. Each ROSS Group Product should be used within its specification limits. In addition, use only ROSS Group components to repair ROSS Group Products.

WARNINGS:

Failure to follow these instructions can result in personal injury and/or property damage.

FILTRATION and LUBRICATION

1. Dirt, scale, moisture, etc., are present in virtually every air system. Although some valves are more tolerant of these contaminants than others, best performance will be realized if a filter is installed to clean the air supply, thus preventing contaminants from interfering with the proper performance of the equipment. The ROSS Group recommends a filter with a 5-micron rating for normal applications.
2. All standard ROSS Group filters and lubricators with polycarbonate plastic bowls are designed for compressed air applications only. Use the metal bowl guard, where provided, to minimize danger from high pressure fragmentation in the event of bowl failure. Do not expose these products to certain fluids, such as alcohol or liquefied petroleum gas, as they can cause bowls to rupture, creating a combustible condition and hazardous leakage. Immediately replace crazed, cracked, or deteriorated bowls.
3. Only use lubricants which are compatible with materials used in the valves and other components in the system. Normally, compatible lubricants are petroleum base oils with oxidation inhibitors, an aniline point between 180°F (82°C) and 220°F (104°C), and an ISO 32, or lighter, viscosity. Avoid oils with

phosphate type additives which can harm polyurethane components, potentially leading to valve failure which risks personal injury, and/or damage to property.

WARNINGS:

Failure to follow these instructions can result in personal injury and/or property damage.

AVOID INTAKE/EXHAUST RESTRICTION

1. Do not restrict air flow in the supply line. To do so could reduce the pressure of the supply air below minimum requirements for the valve and thereby causing erratic action.
2. Do not restrict a valve's exhaust port as this can adversely affect its operation. Exhaust silencers must be resistant to clogging and must have flow capacities at least as great as the exhaust capacities of the valves. Contamination of the silencer can result in reduced flow and increased back pressure.

WARNINGS: Failure to follow these instructions can result in personal injury and/or property damage.

SAFETY APPLICATIONS

1. Mechanical Power Presses and other potentially hazardous machinery using a pneumatically controlled clutch and brake mechanism must use a press control double valve with a monitoring device. A double valve without a self-contained monitoring device should be used only in conjunction with a control system which assures monitoring of the valve. All double valve installations involving hazardous applications should incorporate a monitoring system which inhibits further operation of the valve and machine in the event of a failure within the valve mechanism.
2. Safe Exhaust (dump) valves without a self-contained monitoring device should be used only in conjunction with a control system which assures monitoring of the valve. All Safe Exhaust valve installations should incorporate a monitoring system which inhibits further operation of the valve and machine in the event of a failure within the valve mechanism.
3. Per specifications and regulations, the ROSS L-O-X® and L-O-X® with EEZ-ON®, N06 and N16 Series operation products are defined as energy isolation devices, NOT AS EMERGENCY STOP DEVICES.

WARNINGS:

Failure to follow these instructions can result in personal injury and/or property damage.

STANDARD WARRANTY

All products sold by the ROSS Group are warranted for a one-year period [with the exception of Filters, Regulators and Lubricators (“FRLs”) which are warranted for a period of seven (7) years] from the date of purchase. All products are, during their respective warranty periods, warranted to be free of defects in material and workmanship. The ROSS Group's obligation under this warranty is limited to repair, replacement or refund of the purchase price paid for products which the ROSS Group has determined, in its sole discretion, are defective. All warranties become void if a product has been subject to misuse, misapplication, improper maintenance, modification or tampering. Products for which warranty protection is sought must be returned to the ROSS Group freight prepaid.

THE WARRANTY EXPRESSED ABOVE IS IN LIEU OF AND EXCLUSIVE OF ALL OTHER WARRANTIES AND THE ROSS GROUP EXPRESSLY DISCLAIMS ALL OTHER WARRANTIES EITHER EXPRESSED OR IMPLIED WITH RESPECT TO MERCHANTABILITY OR FITNESS FOR A PARTICULAR PURPOSE. THE ROSS GROUP MAKES NO WARRANTY WITH RESPECT TO ITS PRODUCTS MEETING THE PROVISIONS OF ANY GOVERNMENTAL OCCUPATIONAL SAFETY AND/OR HEALTH LAWS OR REGULATIONS. IN NO EVENT IS THE ROSS GROUP LIABLE TO PURCHASER, USER, THEIR EMPLOYEES OR OTHERS FOR INCIDENTAL OR CONSEQUENTIAL DAMAGES WHICH MAY RESULT FROM A BREACH OF THE WARRANTY DESCRIBED ABOVE OR THE USE OR MISUSE OF THE PRODUCTS. NO STATEMENT OF ANY REPRESENTATIVE OR EMPLOYEE OF THE ROSS GROUP MAY EXTEND THE LIABILITY OF THE ROSS GROUP AS SET FORTH HEREIN.



AMERICAS	ROSS CONTROLS	USA	Tel: +1-248-764-1800	www.rosscontrols.com
	ROSS CONTROLS CANADA Ltd.	Canada	Tel: +1-416-251-7677	www.rosscanada.com
	ROSS DO BRASIL LTDA	Brazil	Tel: +55-11-4335-2200	www.rosscontrols.com.br
EUROPE	ROSS EUROPA GmbH	Germany	Tel: +49 (0)6103-7597-100	www.rosseuropa.com
	ROSS FRANCE SAS	France	Tel: +33-(0)1-49-45-65-65	www.rossfrance.com
	ROSS PNEUMATROL Ltd.	United Kingdom	Tel: +44 (0)1254 872277	www.rossuk.co.uk
ASIA & PACIFIC	ROSS CONTROLS INDIA Pvt. Ltd.	India	Tel: +91-44-2624-9040	www.rosscontrolsindia.com
	ROSS CONTROLS (CHINA) Ltd.	China	Tel: +86-21-6915-7961	www.rosscontrolschina.com
	ROSS ASIA K.K.	Japan	Tel: +81-42-778-7251	www.rossasia.co.jp
	AUTOMATIC VALVE INDUSTRIAL LLC	USA	Tel: +1-248-474-6700	www.automaticvalve.com
	ROSS DECCO COMPANY	USA	Tel: +1-248-764-1800	www.rossdecco.com
	ROSS PNEUMATROL Ltd.	United Kingdom	Tel: +44 (0)1254 872277	www.pneumatrol.com
	manufactIS GmbH	Germany	Tel: +49 (0)2013-16843-0	www.manufactis.net

Full-Service Global Locations

There are ROSS Distributors Throughout the World

To meet your requirements across the globe, ROSS distributors are located throughout the world. Through ROSS or its distributors, guidance is available for the selection of ROSS products, both for those using fluid power components for the first time and those designing complex systems.

Other literature is available for engineering, maintenance, and service requirements.

If you need products or specifications not shown in this catalog, please visit ROSS' website, contact ROSS or your ROSS distributor. The ROSS Support Team will be happy to assist you in selecting the best product for your application.