

Mold clamping system

hydraulic clamp, air clamp, Pascal control unit, solenoid valve unit, operation panel & control box, die setter, octagonal locate-ring, easy ejector rod, ball lock ejector rod

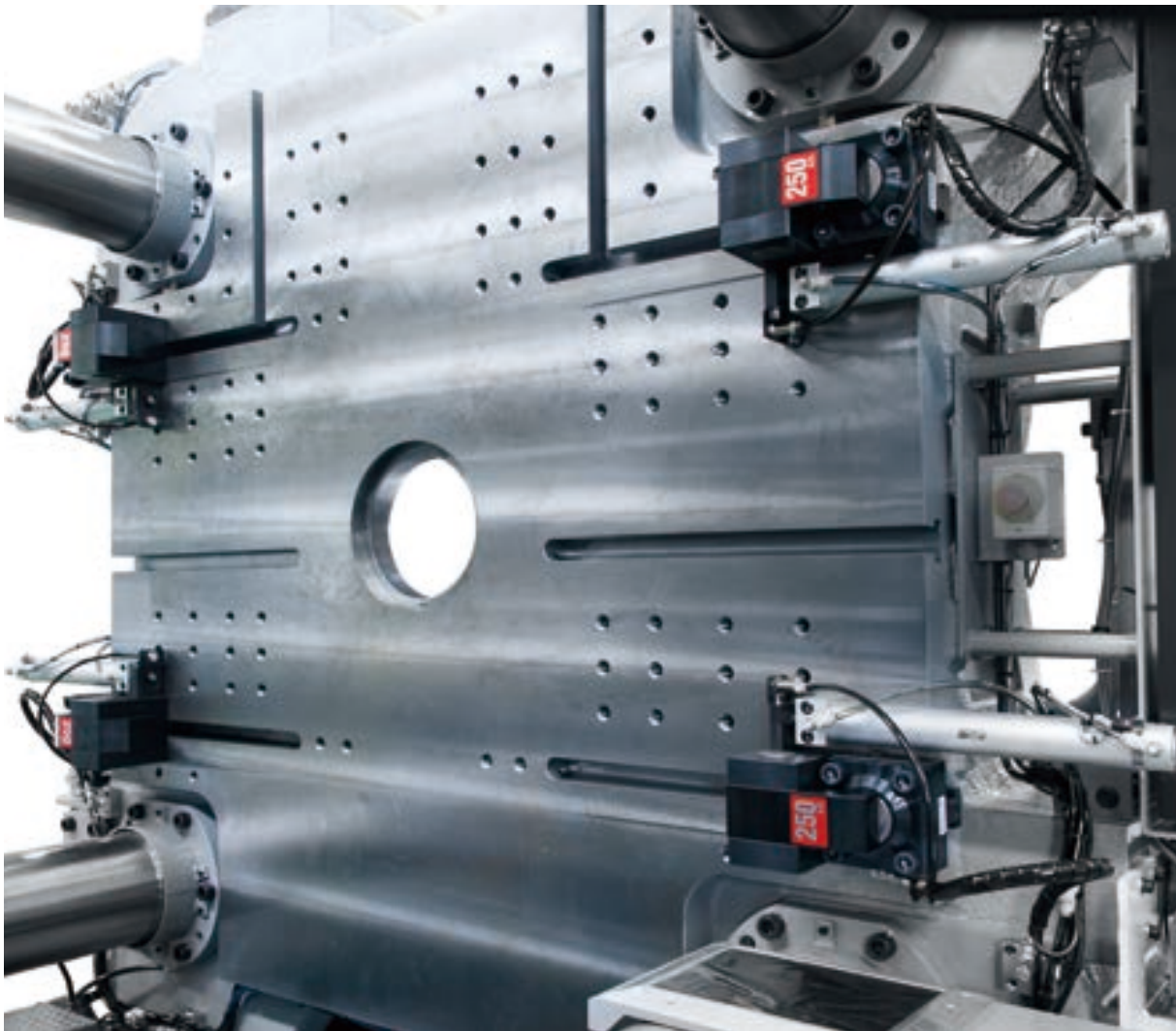

Pascal Mold clamping system

Hydraulic clamp

model **TYA / TYB / TYJ**



T-slotted manual slide type of clamp.

Standard type

model **TYA** page → 28

Long stroke type 15mm

model **TYB** page → 29

Long stroke type 10mm

model **TYJ** page → 30

model **TME**



page → 43

Bolted type of clamp for small and medium size IMM.

model **TYC-Z / TYC-R**



page → 35

Automatic slidable clamp with an air cylinder. It enables to shorten the mold change time.

model **TYA-M**



page → 39

Manual slide type of clamp with a side block (T-slotted block). It enables the clamp to slide it manually even if machine platens do not have T-slots.

model **TKB**



page → 47

Bolted type of clamp for medium and large size IMM.

Control system

Control unit

It is an air-driven hydraulic control unit of the electrical control (solenoid operation), combined with Pascal pump and Pascal non leak valve unit.

Non-leak valve unit

It is a non leak valve unit to control a hydraulic clamp. It is used in case of utilizing hydraulic pressure source from machine pump.

model **HCS**
(For small and medium-sized IMM)



page → 75

model **HCM**
(For medium and large-sized IMM)



page → 77

model **HCP**
(For medium and large-sized IMM)



page → 79

model **HCE**
(For large sized IMM)



* Refer to another separate catalogue for details.

model **VSE**



page → 81

model **VSL**
(For large volume on circuit)



page → 82

Positioning device

Die setter

model **MDL**



page → 87

This is an elevating positioning block. It enables to perform the horizontal and vertical positioning surely and easily.

Octagonal locate ring

model **MCL**



page → 105

Locate ring adopting an octagonal tapered cone enabling rotation to be restricted.

Easy ejector rod

model **MEJ**



page → 117

Innovative style of ejector rod having a strong magnet on both of fixed and movable rod makes the rod change quicker and easier.

Ball lock ejector rod

model **MEL**



page → 123

The ejector rod can be installed and removed at one-touch operation owing to the ball lock structure.

Accessory

Pascal Mold clamping system

Air clamp

model **TLC**



page → 51

T-slotted manual slide type of clamp.

model **TLC-Z / TLC-R**



page → 55

Automatic slidable clamp with an air cylinder. It enables to shorten the mold change time.

model **TLA-M**



page → 59

Manual slide type of clamp with a side block (T-slotted block). It enables the clamp to slide it manually even if machine platens do not have T-slots.

model **TLA**



page → 63

Bolted type of clamp.

Solenoid valve unit

It is a valve unit combined with solenoid valve and pressure switch. It is used for the control of air clamp.

model **GSC**



page → 83

Operation panel & Control box

It is a operation panel and control box for hydraulic and air clamp. It displays the state of clamp interlock clearly.

Operation panel

model **ESTE**



page → 85

Control box

model **ECTL**



page → 86

Operation panel ELC-B

It is an economical clamping system that limits the specifications of clamp and streamlines the operation control platen.

model **ELC-B**



page → 125

Other products page → 127

Auto coupler



C & C coupler



Multi-coupler



Mold changer



Mold rotator

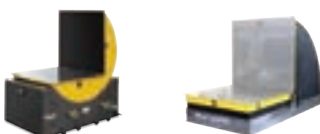

model **SMR**

Robot tool changer



N2 gas spring



model **SMF**



Pascal Mold clamping system

Nowadays the needs of market is diversifying and the world economy is fluctuating so much. In the production lines of various industries, it is one of our assignments to produce the required quantity (small lot) in a short delivery time, to realize the stockless production and to attempt the more efficient management. At the same time, in the production line, the more secure and comfortable work environment has been required due to varieties of changes in work environment. That is to say, it is a theme that the production lines will have to accomplish ensuring the introduction of single set up or mold clamping system so that we can overcome the severe competition in the global market, on both aspects of management and labors.



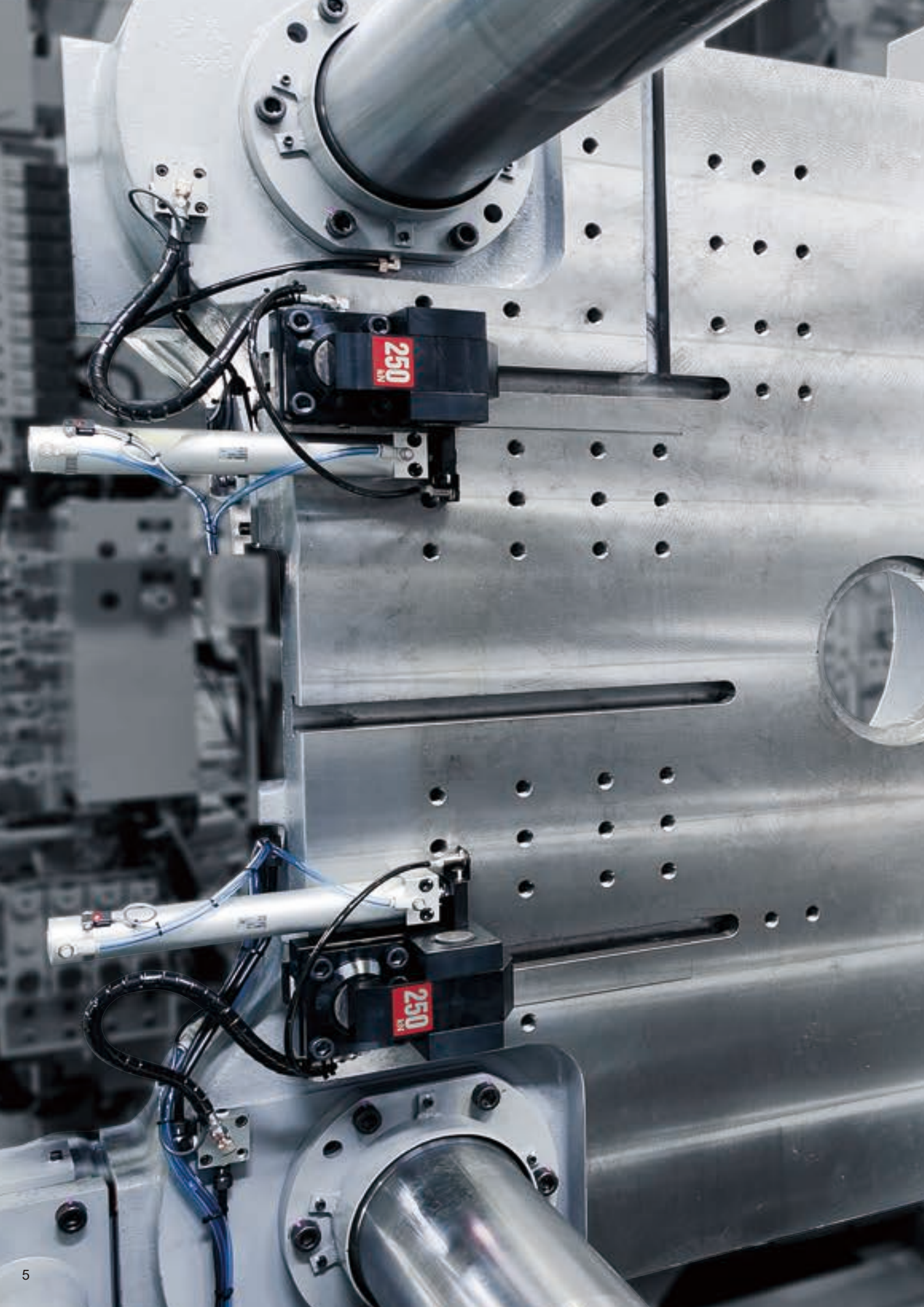



Hydraulic clamp,
automatic slidable type
TYC250Z

16,000kN (1,600ton) IMM

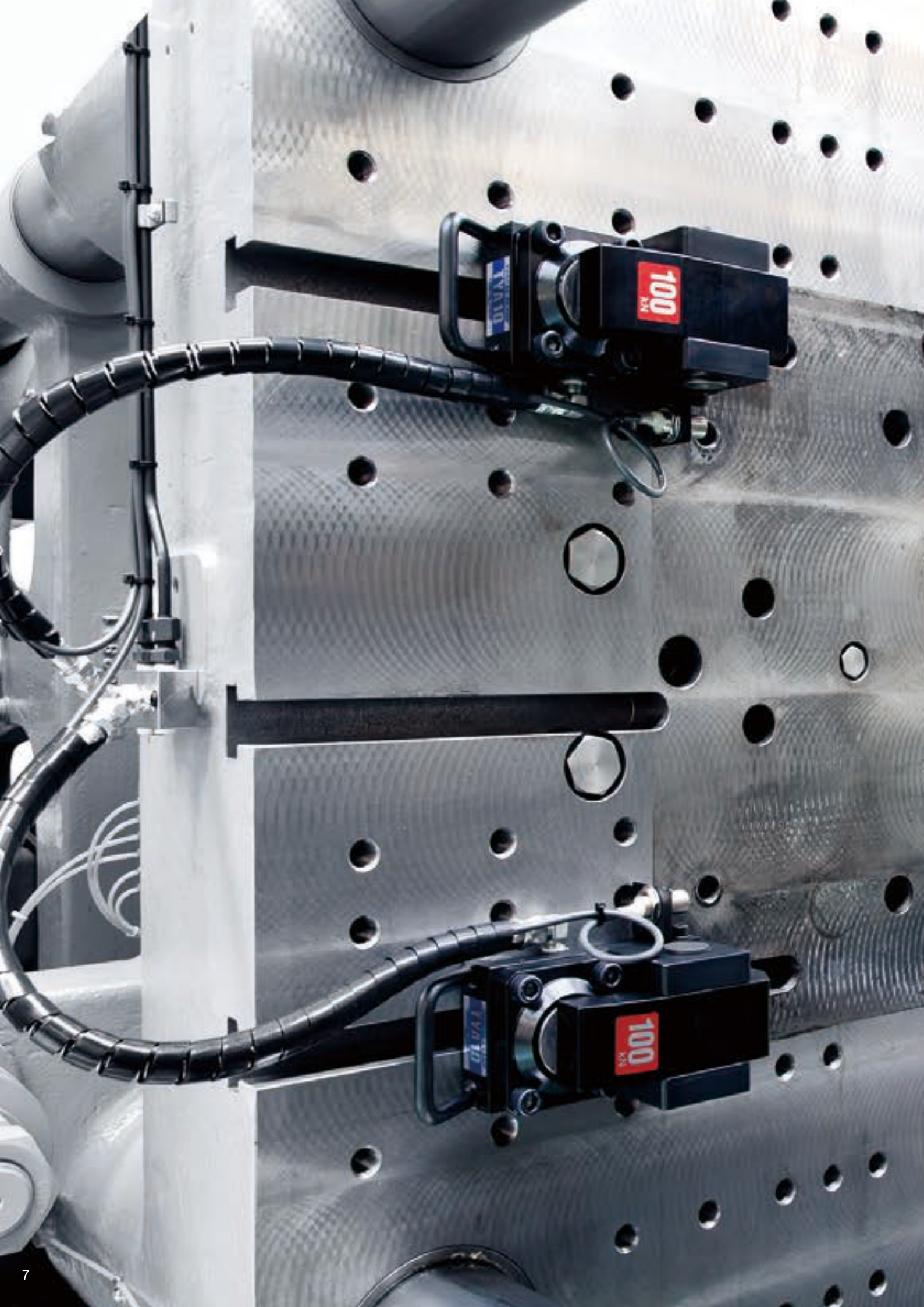

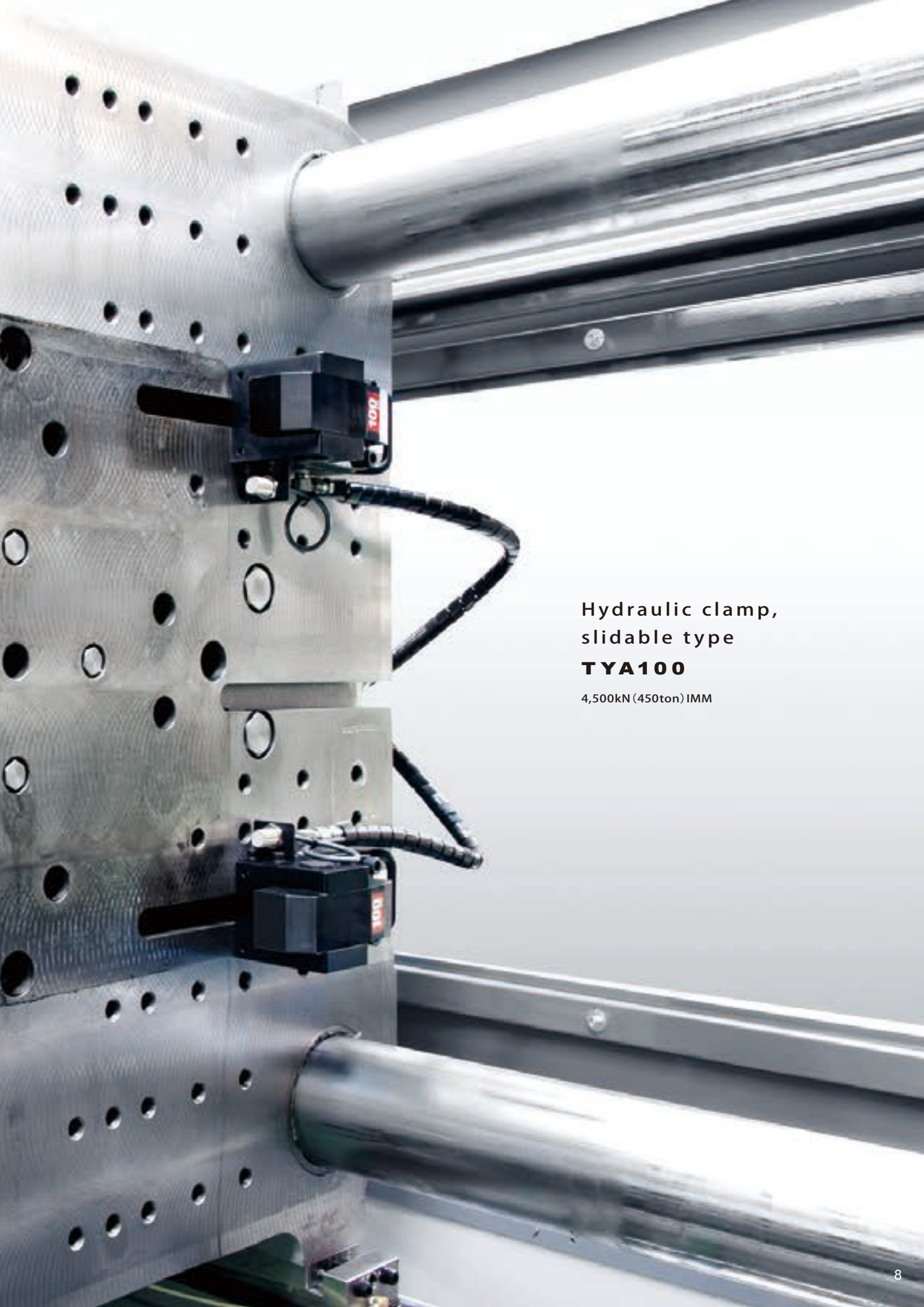

Hydraulic clamp,
slidable type

TYA100

4,500kN (450ton) IMM

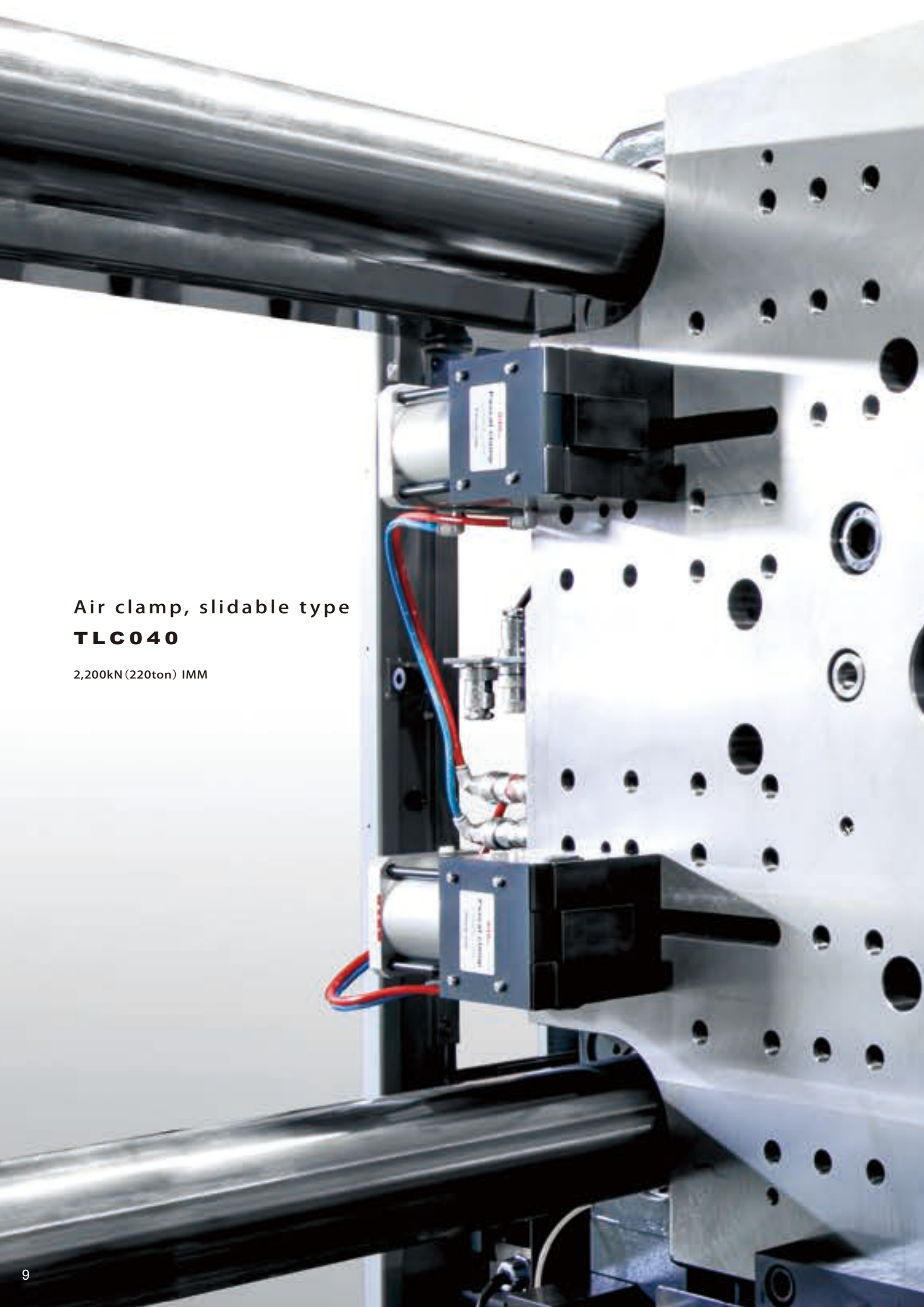

Air clamp, slidable type
TLC040

2,200kN (220ton) IMM

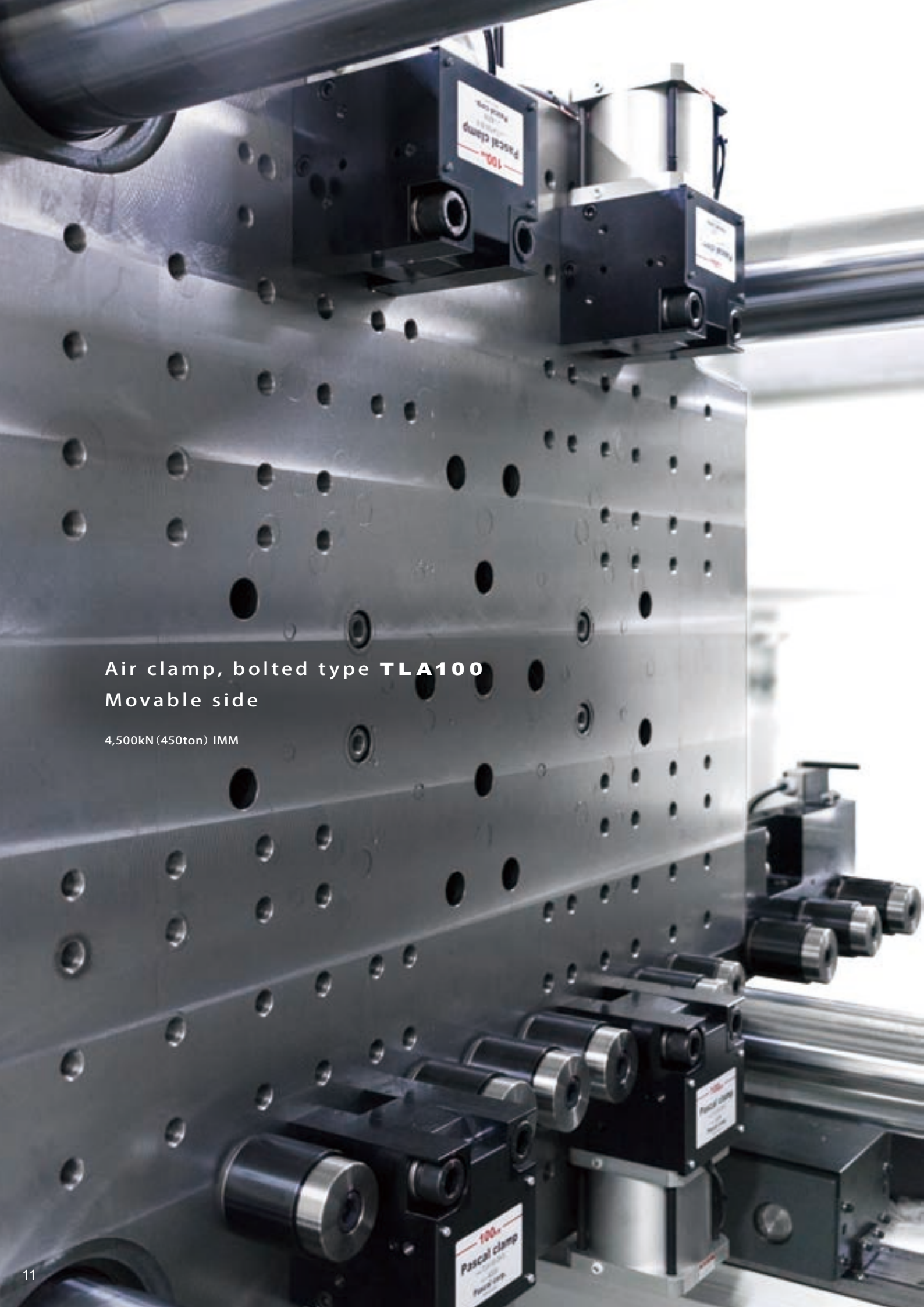
The image shows a close-up of a large industrial machine. A prominent feature is a large, dark grey metal plate with a regular grid of circular holes. Several hydraulic clamps, labeled 'Pascal clamp 100', are mounted on the machine. These clamps are black and silver, with some having pneumatic cylinders attached. The machine is set in a bright, industrial environment.

Air clamp, bolted type TLA100
Movable side

4,500kN (450ton) IMM



Air clamp, bolted type **TLA100**
Fixed side

4,500kN (450ton) IMM

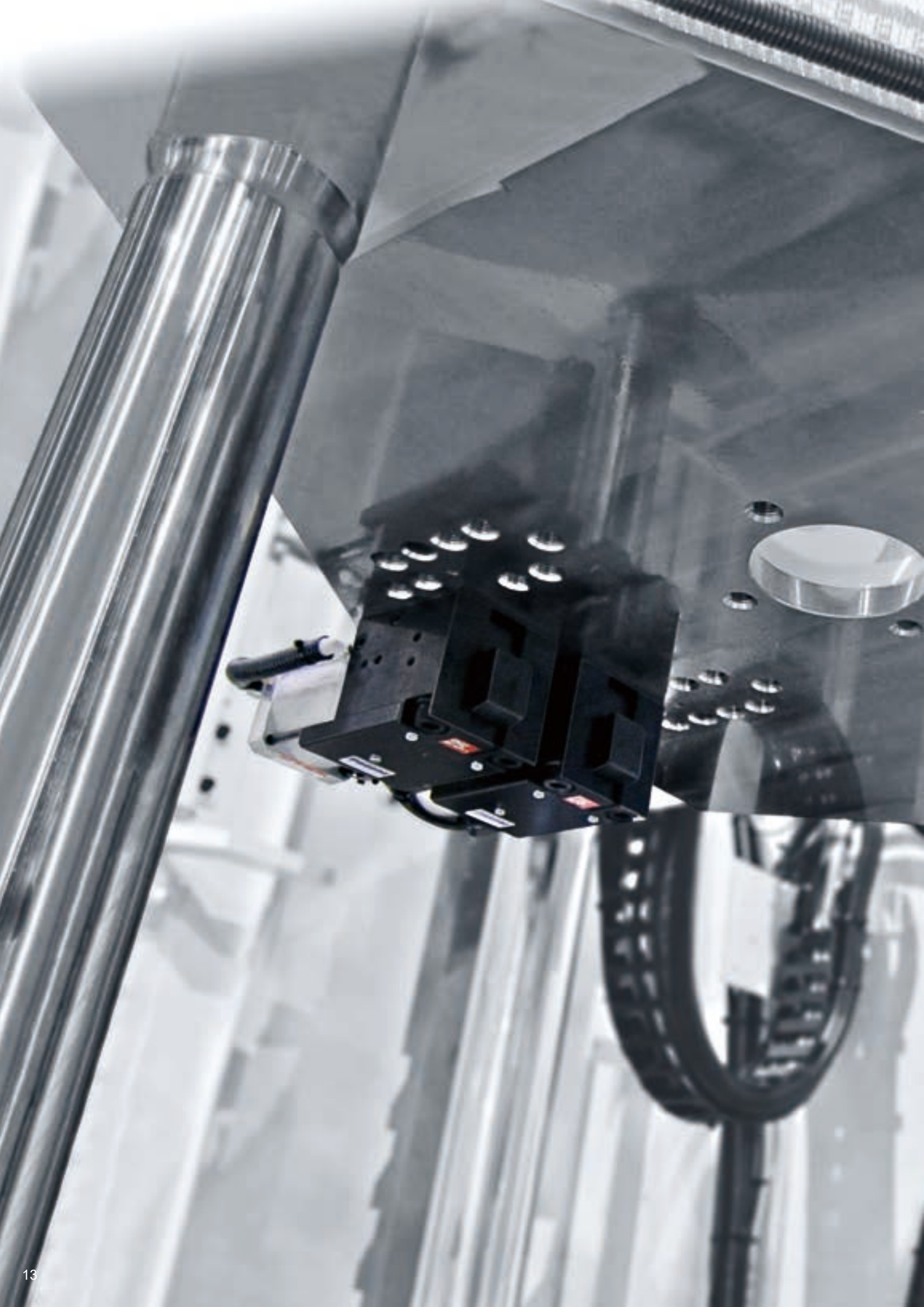

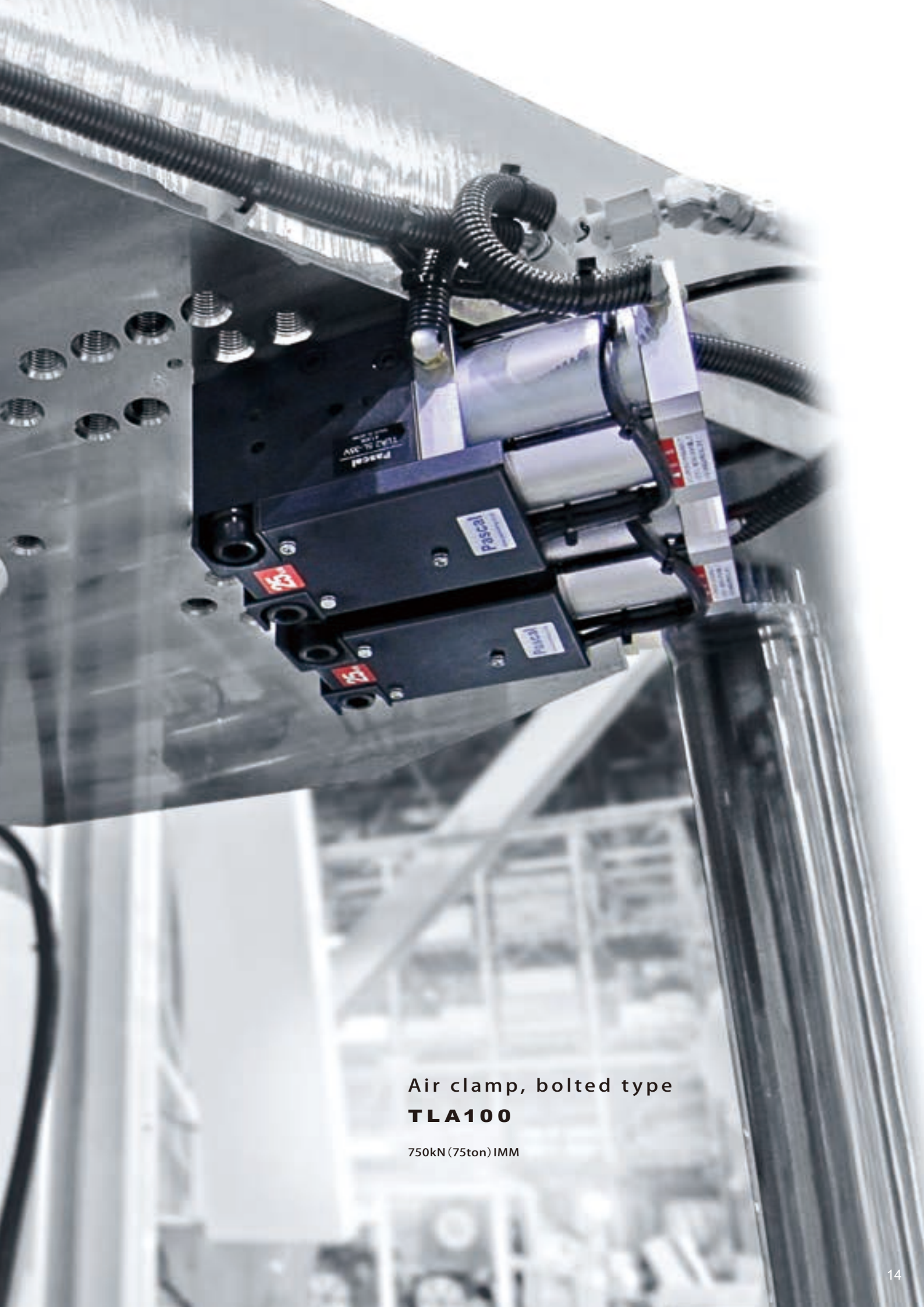

Air clamp, bolted type
TLA100

750kN (75ton) IMM



Air clamp, bolted type **TLA100** & Mold die changer

4,500kN (450ton) IMM

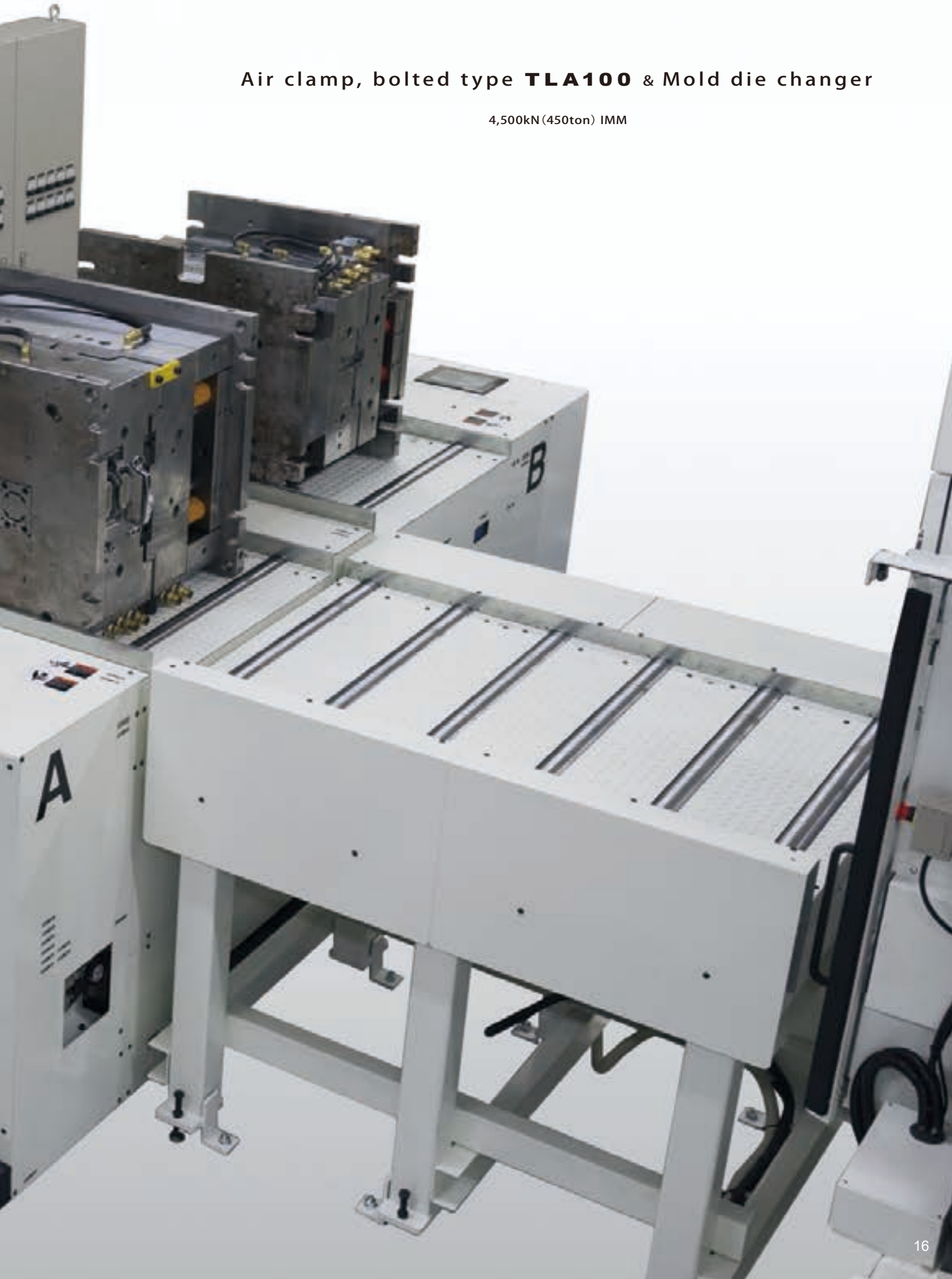



A

MAX. DIE WEGT
300 kg

安全操作
1
警告

B

MAX. DIE WEGT
300 kg

Air clamp, bolted type **TLA010** & Mold die changer

500kN (50ton) IMM

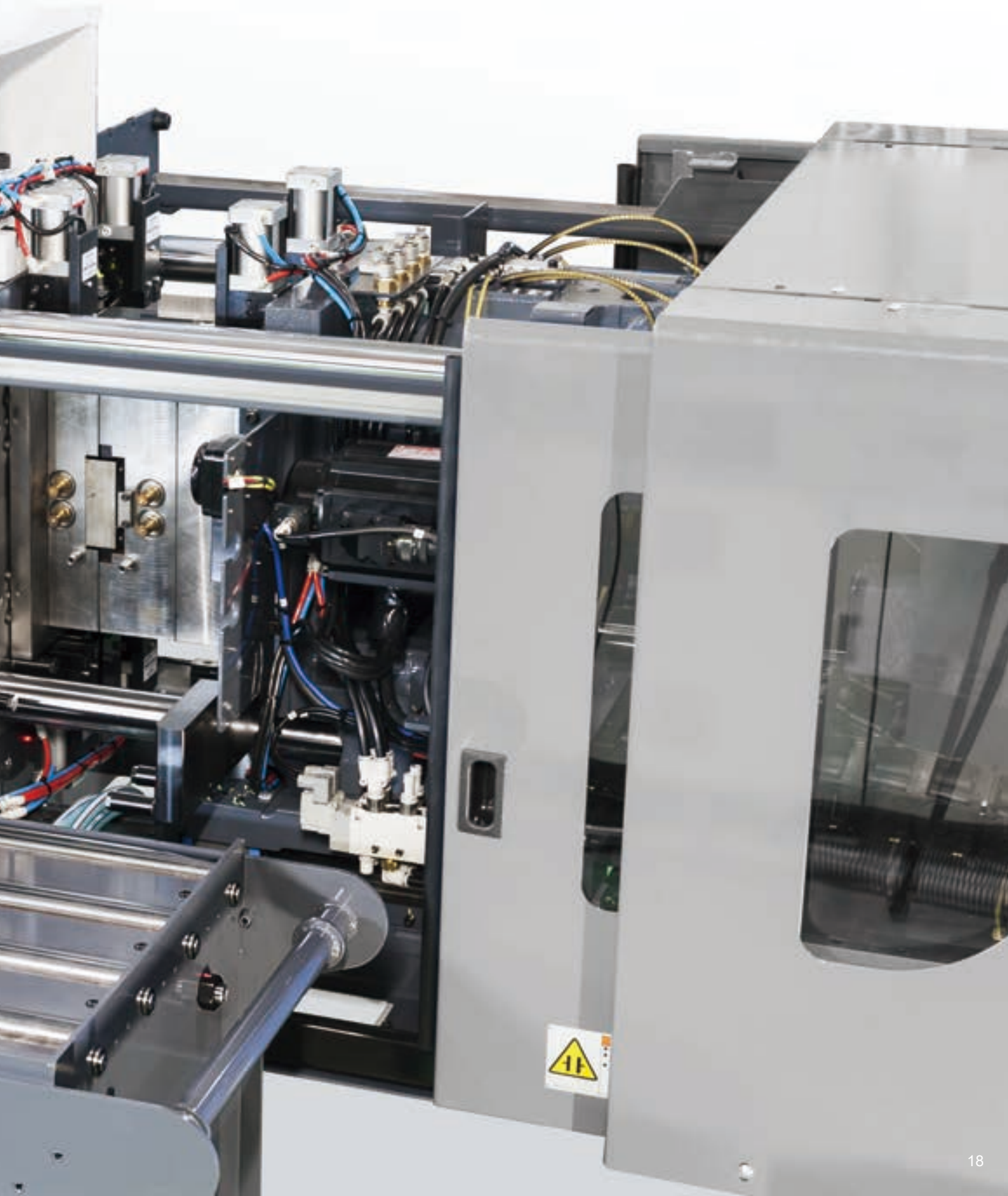

The reduction of non-productive time (Set up time)

by means of the automation of mold clamp.

For a typical introduction minutes with the medium minutes and reduce 30% of bers of operators and work

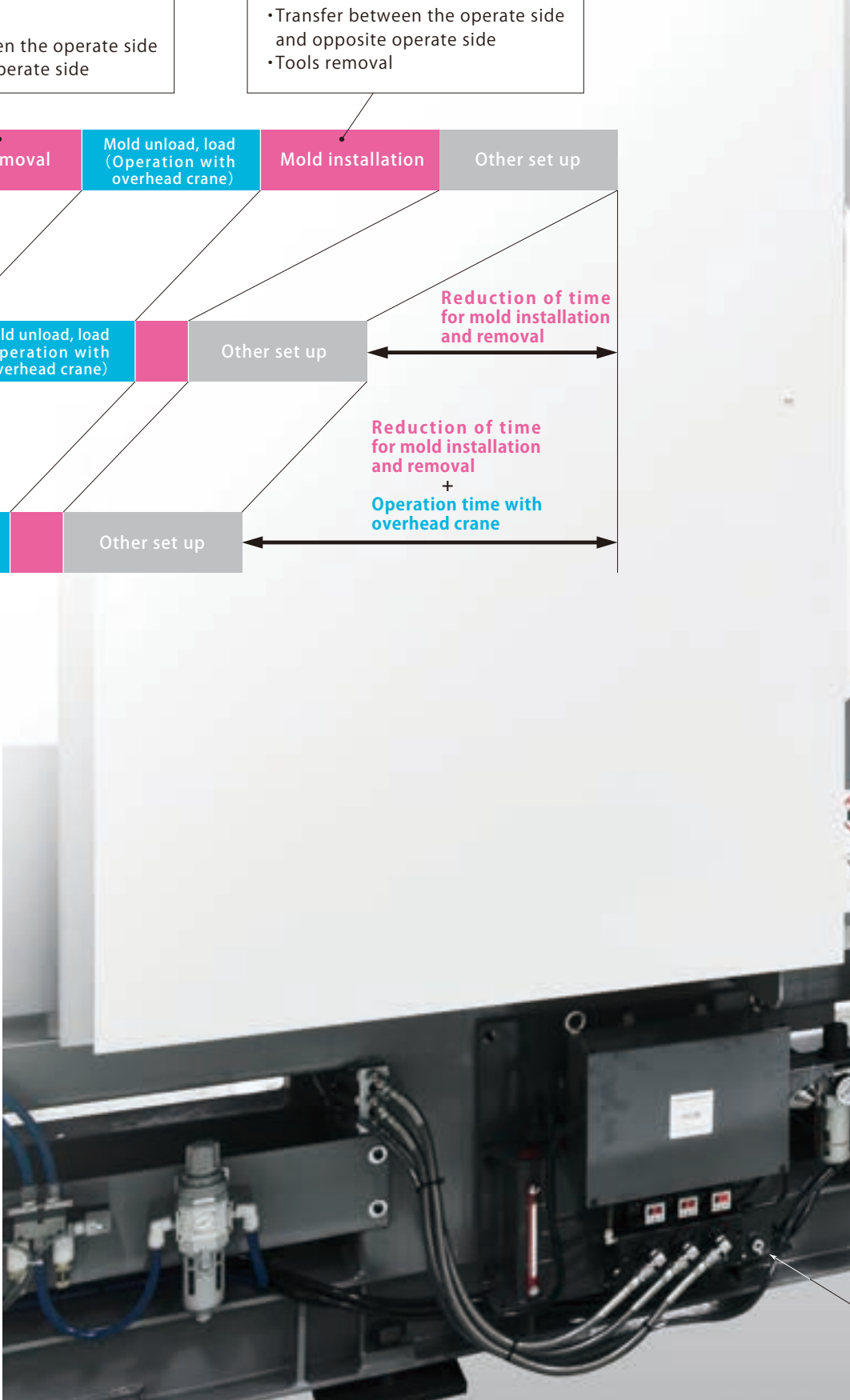
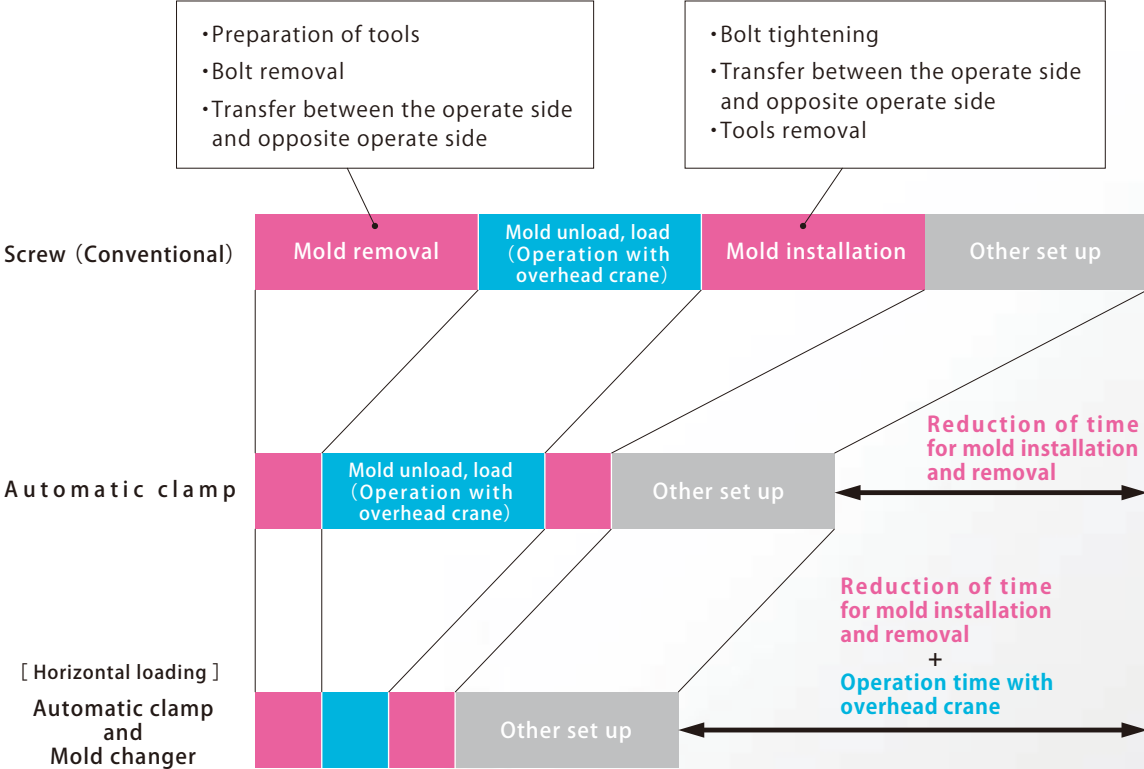

example, introducing the mold clamping system enables to shorten the mold change time from 60 minutes to 30 and large sized IMM. Introduction of the Mold changer also enables to shorten the mold change time drastically to 5 time in the production line where the mold is changed five times per day. In addition, it enables to reduce the num-
burden.

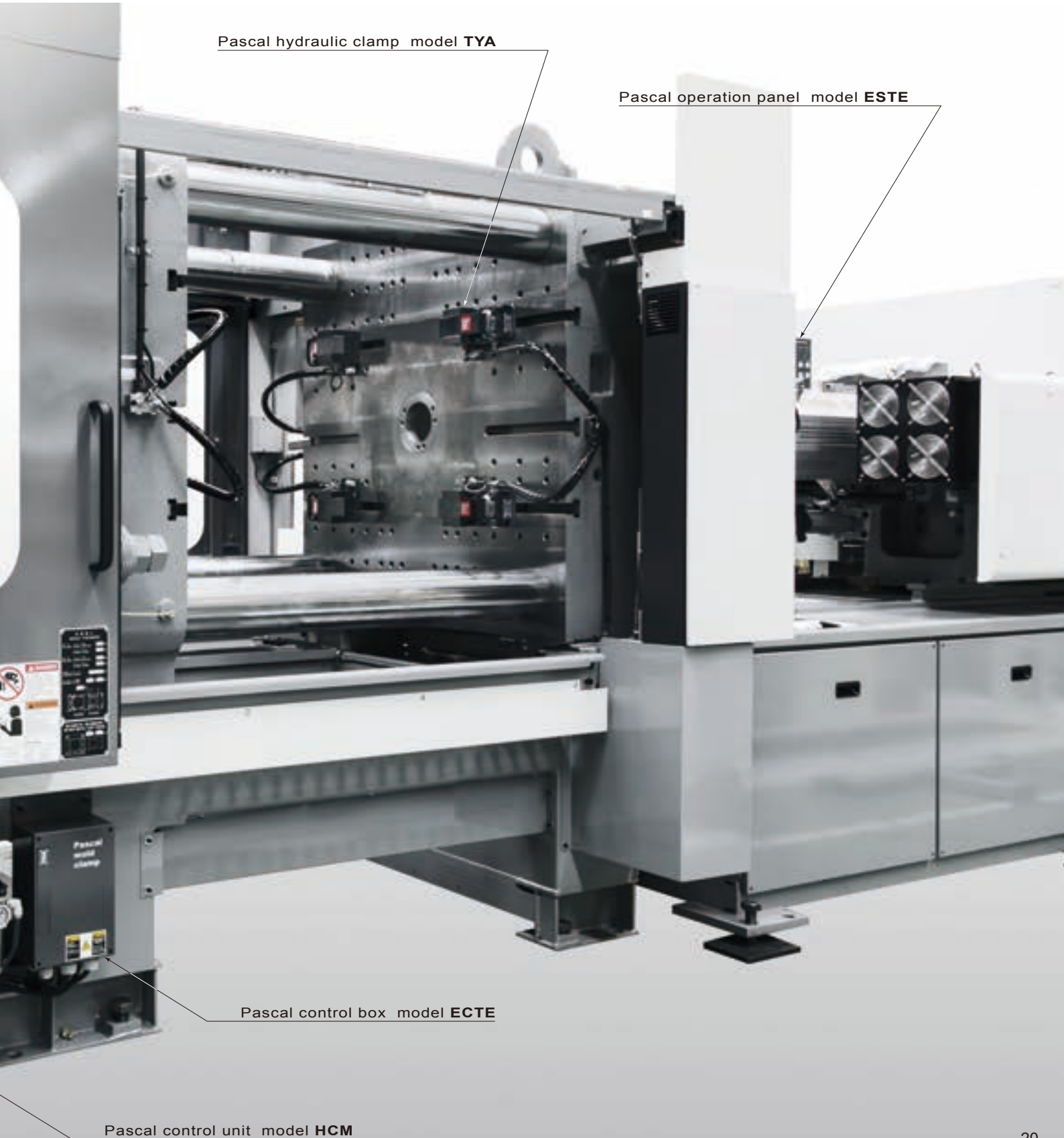

Pascal hydraulic clamp model **TYA**

Pascal operation panel model **ESTE**

Pascal control box model **ECTE**

Pascal control unit model **HCM**

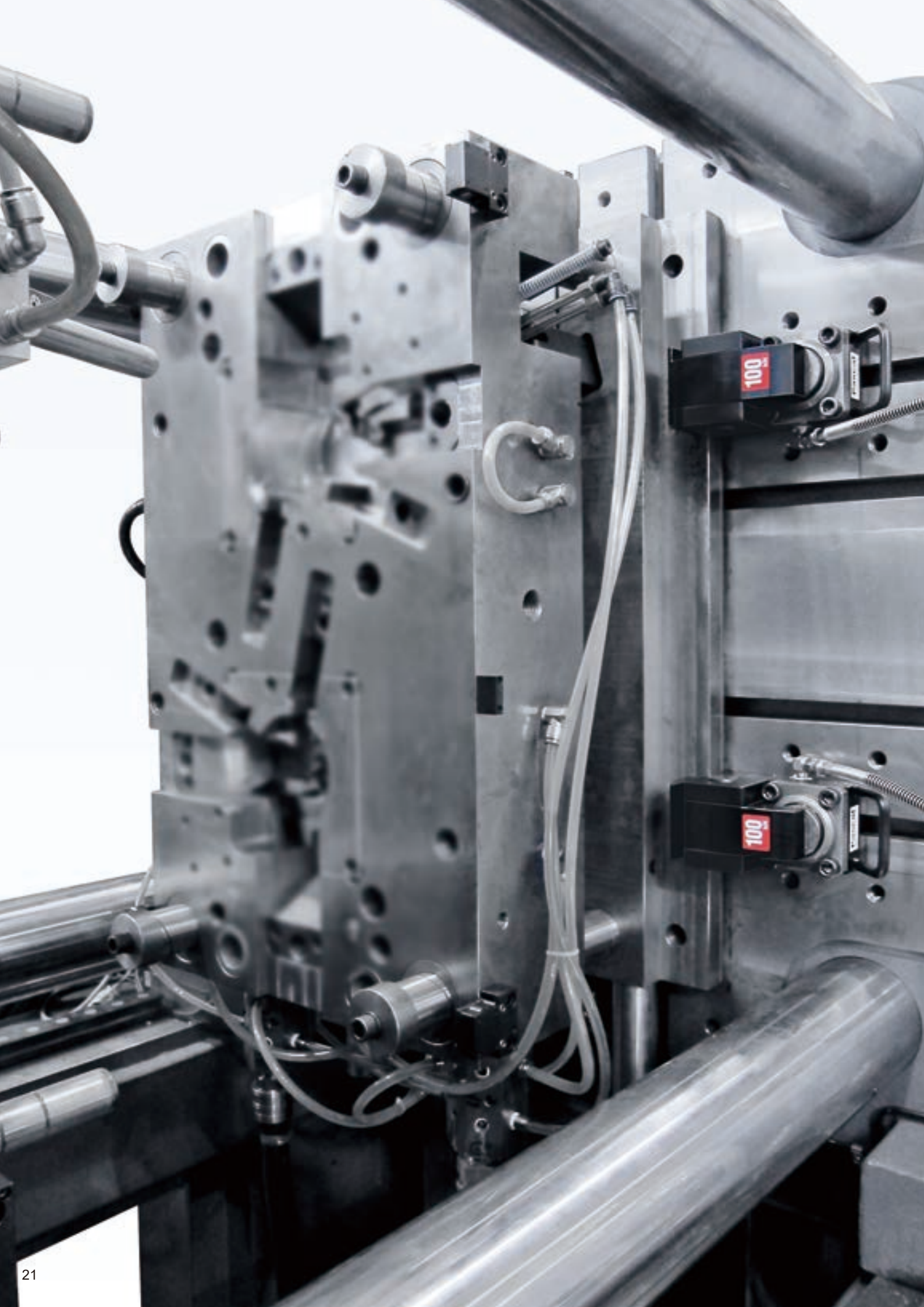

IMM vertical loading

Slidable type

Hydraulic model **TYA** page → 28
 model **TYB** page → 29
 model **TYJ** page → 30

Air model **TLC** page → 55

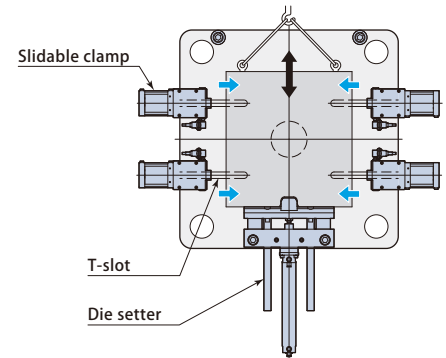

Mold plate thickness	Mold plate width	T-slot
Unified	Not unified	With T-slot

- Refer to page → 68, regarding the unification of mold plate thickness.

Automatic slidable type

Hydraulic model **TYC-Z/R** page → 35

Air model **TLC-Z/R** page → 59

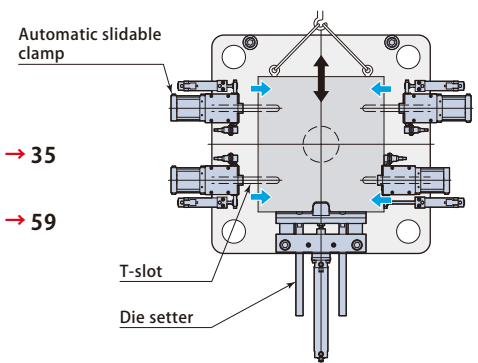

Mold plate thickness	Mold plate width	T-slot
Unified	Not unified	Without T-slot

- Refer to page → 68, regarding the unification of mold plate thickness.

T-slot-less slidable type

Hydraulic model **TYA-M** page → 39

Air model **TLA-M** page → 63

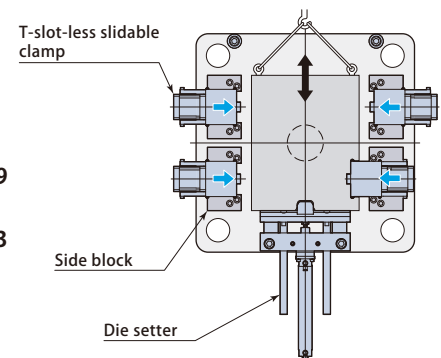

Mold plate thickness	Mold plate width	T-slot
Unified		—

Bolted type

For small and medium-sized IMM

Hydraulic model **TME** page → 43

For medium and large-sized IMM

Hydraulic model **TKB** page → 47

Air model **TLA** page → 67

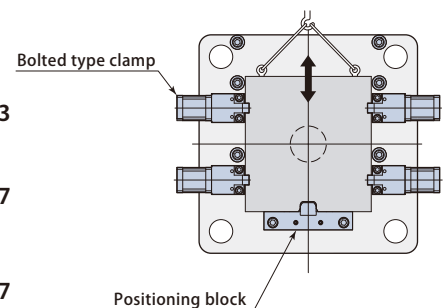

Mold plate thickness	Mold plate width	T-slot
Not unified		—

Mag clamp

It clamps mold instantly with strong everlasting magnet (neodymium magnet, alnico magnet). It is unnecessary to unify the "thickness" and "width" of mold plate.



* It is not mentioned in this catalogue. Contact Pascal for the details.

IMM horizontal loading

Mold plate thickness	Mold plate width	T-slot
Unified		—

Mold plate thickness	Mold plate width	T-slot
Not unified		—

Bolted type clamp

For small and medium-sized IMM

Hydraulic model **TME** page → 43

For medium and large-sized IMM

Hydraulic model **TKB** page → 47

Air model **TLA** page → 67

Mag clamp

The introduction of automatic clamp by IMM horizontal loading needs the unification of "thickness" and "width" of mold plate.

In case that it is not unified, it can be applied with the mag clamp.

* It is not mentioned in this catalogue. Contact Pascal for the details.

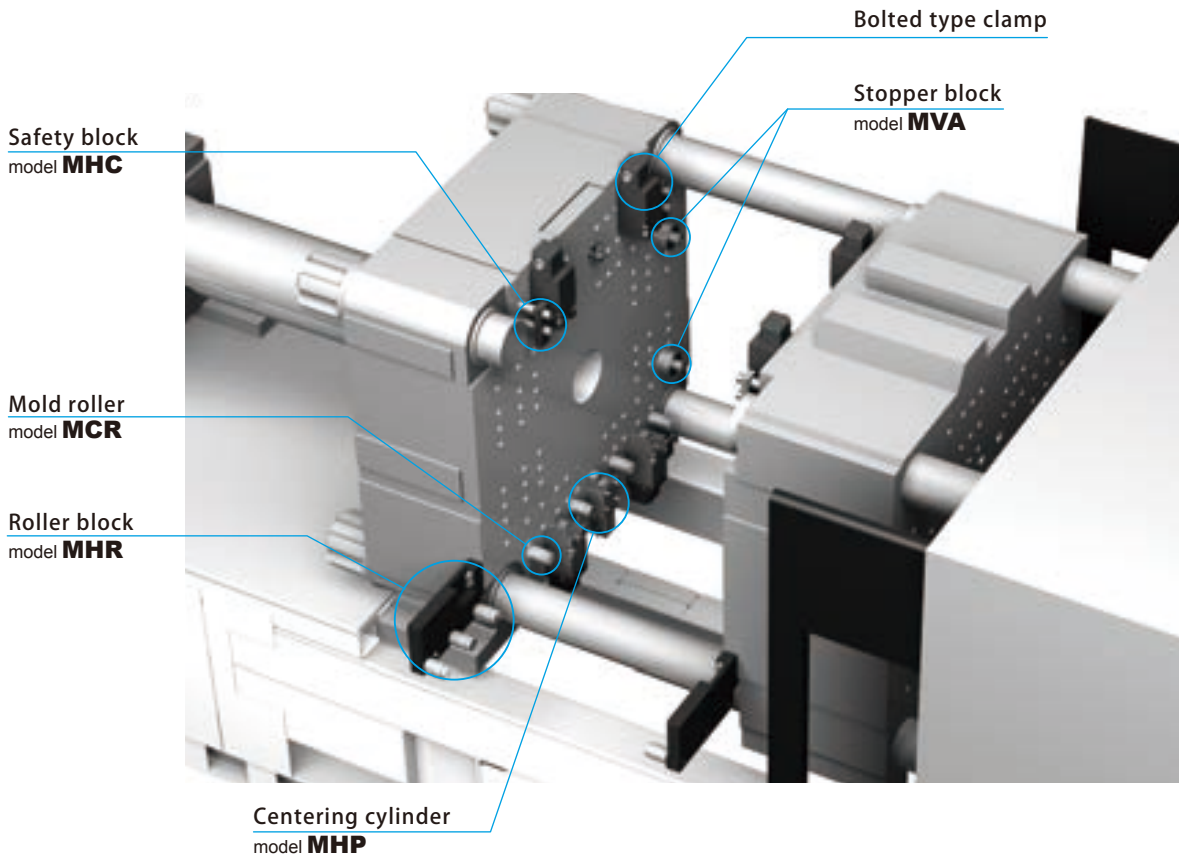

Selecting table for mold roller, centering cylinder, stopper block and safety block.

IMM Mold clamping force kN	~500	~1000	~2000	~3500	~4500	~5500	~6500	~8500	~10000	~13000	~20000	~25000	~30000
Mold roller	MCR020K	MCR040K	MCR060K	MCR080K		MCR100K		MCR120K	MCR160K	MCR180K			
Centering cylinder	MHP1		MHP2			MHP3			MHP4				
Stopper block	MVA030	MVA040	MVA060		MVA080			MVA100					
Safety block	MHC08	MHC12	MHC16	MHC20	MHC24			MHC30					

Selection of mold clamping system

For small and medium-sized IMM

Hydraulic model **TME**

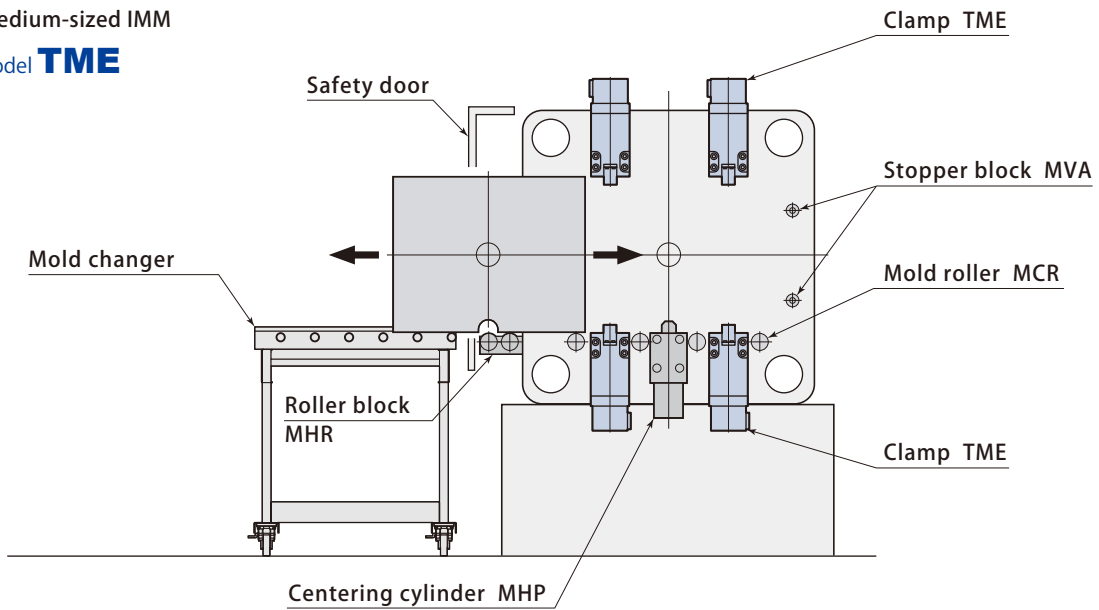

For medium and large-sized IMM

Hydraulic model **TKB**

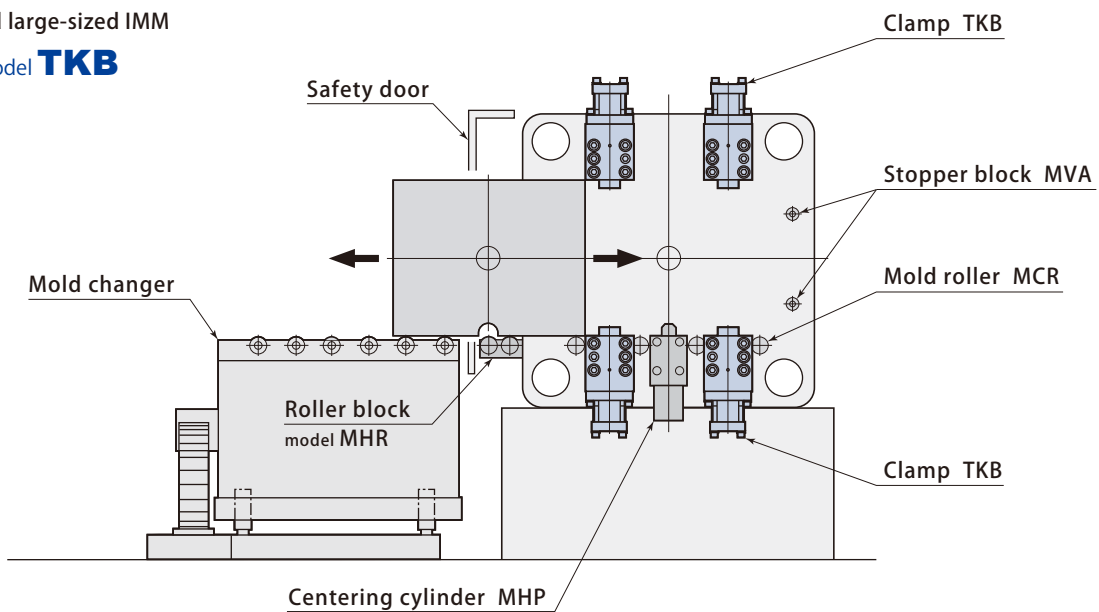

For small, medium and large-sized IMM

Air model **TLA**

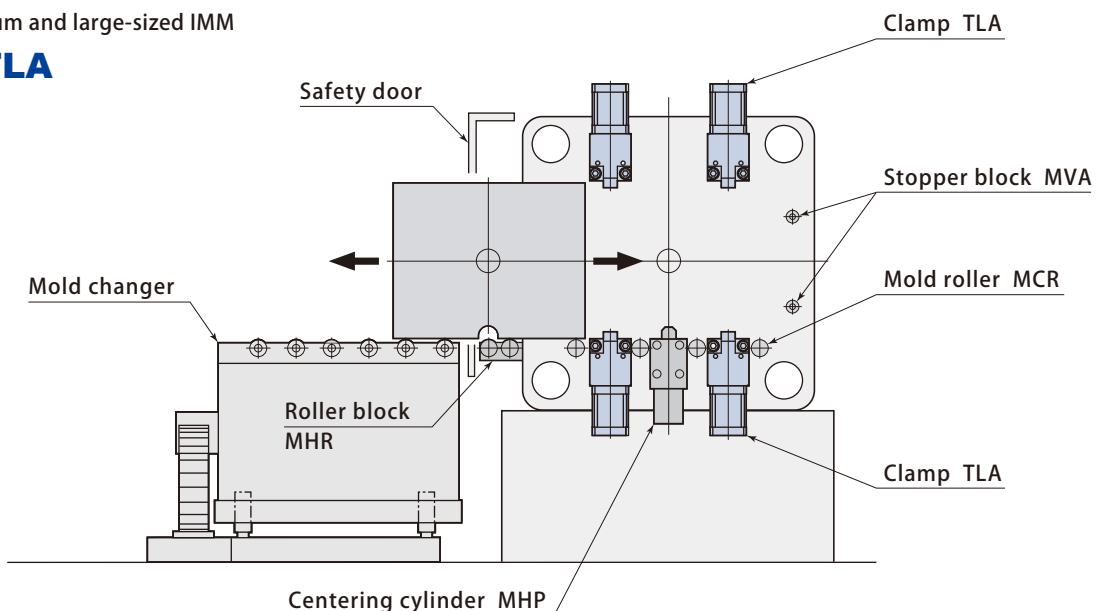

Selection of mold clamping system

Selection of mold clamping system

Hydraulic

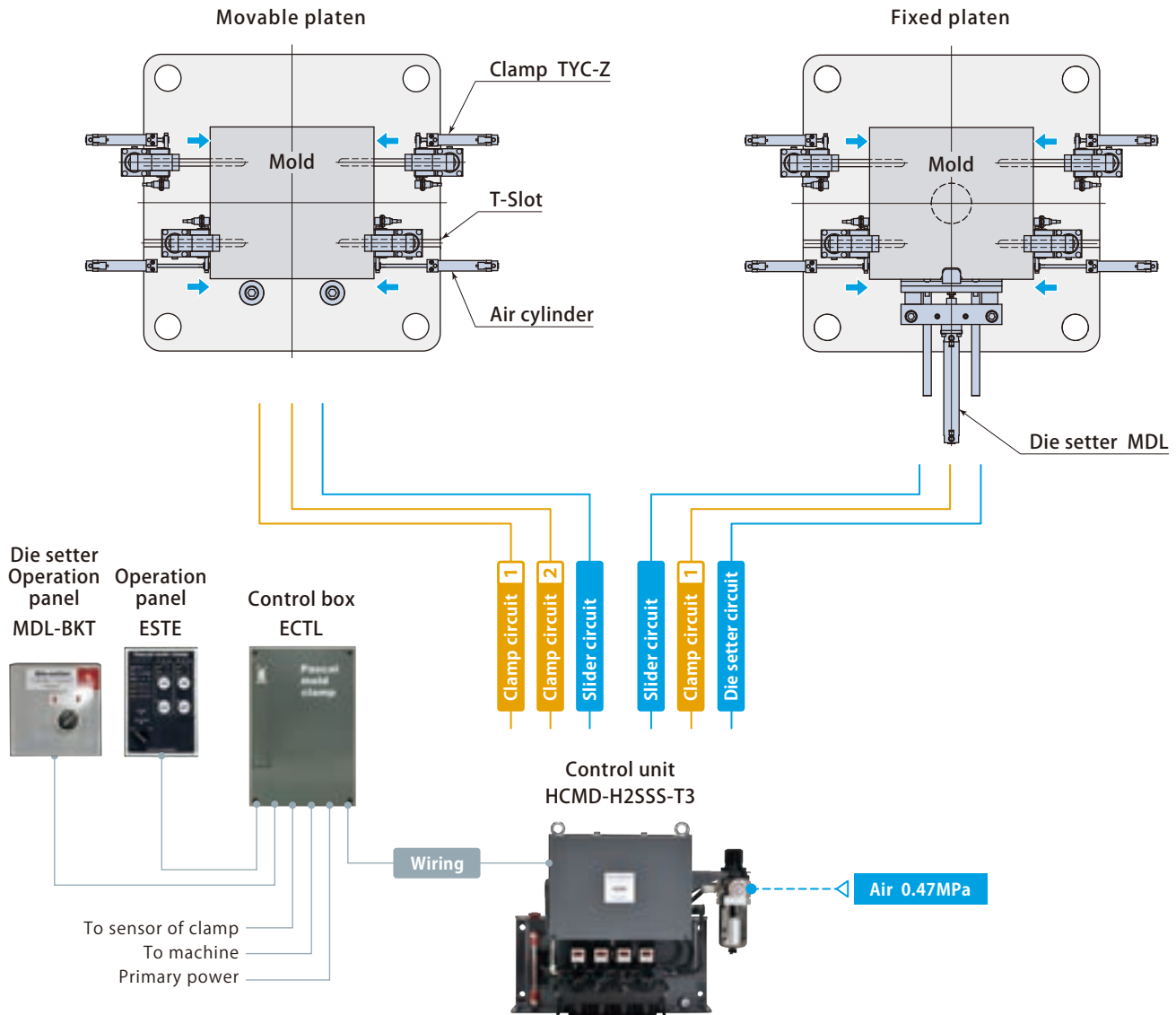

Selecting table for hydraulic clamp and control unit

IMM	Mold clamping force kN	~500	~1000	~1500	~2000	~3500	~5500	~6500	~8500	~13000	~30000	~35000
	Mold opening force kN	40	80	100	160	250	400	640(400)	640	1000	1600	2000
TYA TYB TYJ TYA-M	Hydraulic clamp (Fixed platen/ movable platen each 4)	TYA010 TYA010M	TYA020 TYA020M	TYA040 TYB040 TYA040M	TYA063 TYB063 TYJ063 TYA063M	TYA100 TYB100 TYJ100 TYA100M	TYA160 TYB160 TYJ160 TYA160M	TYA250 TYB250 TYJ250				
	Control unit	HCMD-H2SSS						HCMD-H22SSS				
TYC-Z	Hydraulic clamp (Fixed platen/ movable platen each 4)		TYC020Z	TYC040Z	TYC063Z	TYC100Z	TYC160Z	TYC250Z				
	Control unit	HCMD-H2SSS-T3						HCMD-H22SSS-T3				
TYC-R	Hydraulic clamp (Fixed platen/ movable platen each 4)		TYC020R	TYC040R	TYC063R	TYC100R	TYC160R	TYC250R				
	Control unit	HCMD-H2SSS-T2						HCMD-H22SSS-T2				
TME TKB	Hydraulic clamp (Fixed platen/ movable platen each 4)	TME010	TME025	TME040	TME063	TME100	TME160 (TME100)	TME160 (TKB160)	TKB250	TKB400	TKB500	
	Control unit	HCMD-H3CSSS			HCMD-H33CSSS		HCEF-3-H3CSSS *					

● The clamping force shall be determined based on the machine mold opening force. Contact Pascal for further assistance if the actual opening force is greater than the values shown in the above table.

● Regarding Control unit, refer to **page → 75**, Die setter **page → 87**, Operation panel **page → 85**, and Control box **page → 86**.

* It is not mentioned in this catalogue. Contact Pascal for the details.

Air

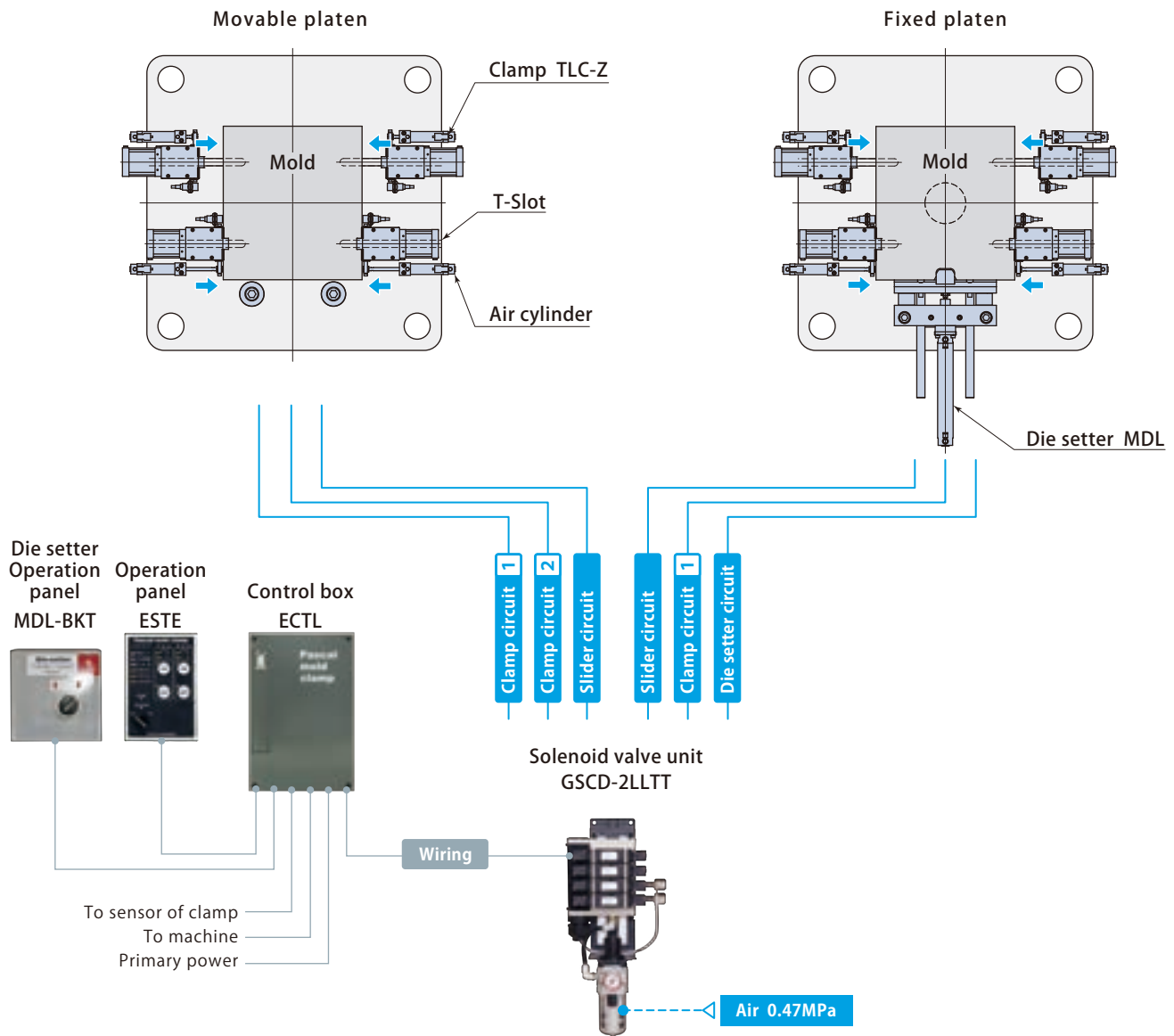

Selecting table for air clamp and solenoid valve unit

IMM	Mold clamping force kN	~500	~800	~1250	~2000	~3500	~5500	~6500	~8500
	Mold opening force kN	40	64	100	160	250	400	640	1000
TLC TLA-M	Air clamp (Fixed platen/ movable platen each 4)	TLC010 TLA010M	TLC016 TLA016M	TLC025 TLA025M	TLC040 TLA040M	TLC063 TLA063M	TLC100	TLC160	
	Solenoid valve unit	GSCD-1LL					GSCD-2LL		
TLC-Z	Air clamp (Fixed platen/ movable platen each 4)	TLC010Z	TLC016Z	TLC025Z	TLC040Z	TLC063Z	TLC100Z	TLC160Z	
	Solenoid valve unit	GSCD-1LLTT					GSCD-2LLTT		
TLC-R	Air clamp (Fixed platen/ movable platen each 4)	TLC010R	TLC016R	TLC025R	TLC040R	TLC063R	TLC100R	TLC160R	
	Solenoid valve unit	GSCD-1LLTT					GSCD-2LLTT		
TLA	Air clamp (Fixed platen/ movable platen each 4)	TLA010	TLA016	TLA025	TLA040	TLA063	TLA100	TLA160	TLA250
	Solenoid valve unit	GSCD-1LL					GSCD-2LL		

- The clamping force shall be determined based on the machine mold opening force. Contact Pascal for further assistance if the actual opening force is greater than the values shown in the above table.
- Regarding Solenoid valve unit, refer to **page → 83**, Die setter **page → 87**, Operation panel **page → 85**, and Control box **page → 86**.

T-slotted slidable clamp with compact body and large clamping stroke, equipped with a strong clamping force and high rigidity to resist shock.

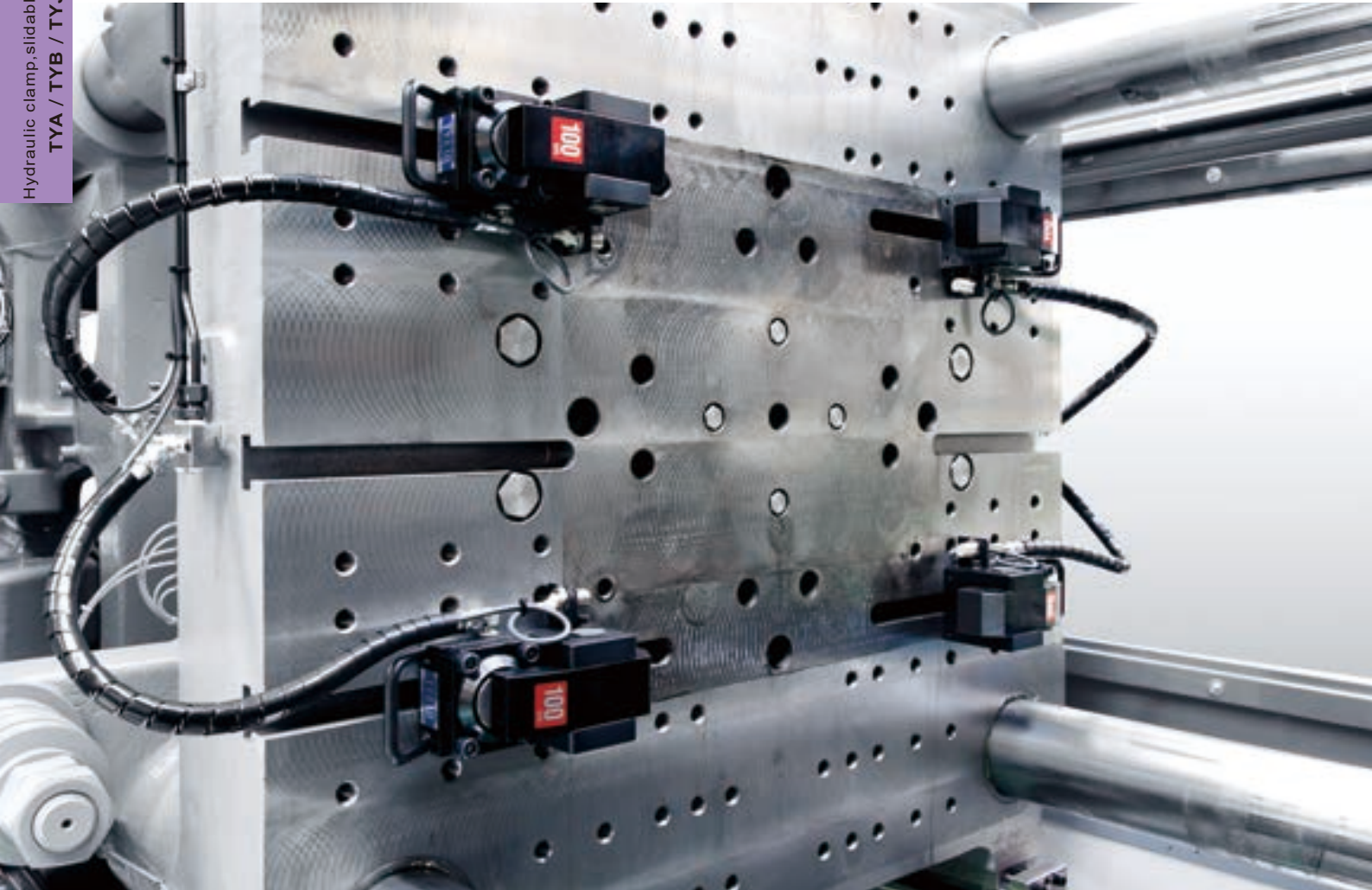

4,500kN (450ton) IMM vertical loading Hydraulic clamp, slidable type TYA



model **TYA**

Standard type

page → 28



model **TYB**

Long stroke type

The **max. 5mm** (in case of using a lever spacer, **max. 15mm**) of dimensional variation can be absorbed.

page → 29



model **TYJ**

Long stroke type

The **max. 10mm** of dimensional variation can be absorbed.

page → 30

• Standard type



model **TYA**

■ Model designation **TYA 020**

■ Option

Refer to page → 34

1 Clamping force

Hydraulic clamp, slidable type TYA

TYA & Die setter

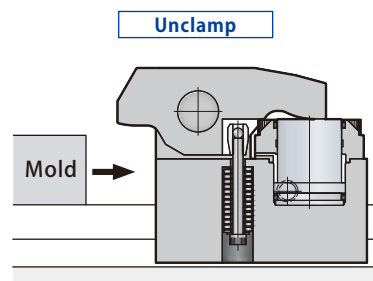
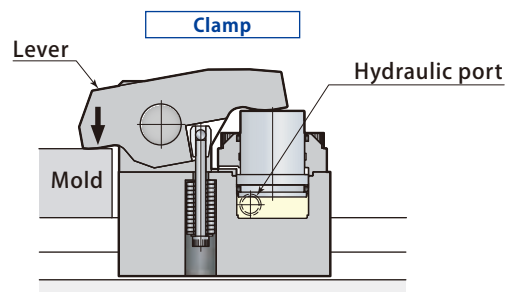
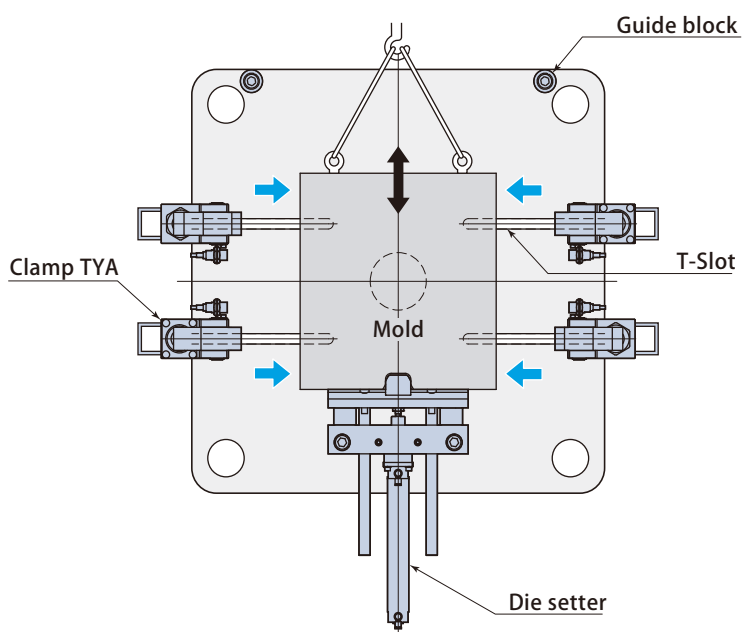

It is mounted on the T-slot and slid manually.

1 Specifications

Model		TYA010	TYA020	TYA040	TYA063	TYA100	TYA160	TYA250
Clamping force (at 24.5 MPa)	kN	9.8	19.6	39.2	61.7	98	156	245
Full stroke	mm	6	7	7	8	8	8	8
Clamping stroke	mm	3	4	4	4	4	4	4
Safety stroke	mm	3	3	3	4	4	4	4
Cylinder capacity (at full stroke)	cm ³	2.4	6.3	13.2	22.3	37	61	93
Proof pressure	MPa	36.7						
Working hydraulic pressure	MPa	24.5						
Operating temperature	°C	0 ~ 70 (5 ~ 120 by heat proof type)						
Weight	kg	1	3	4.5	9	15	25	35

- Safety stroke and clamping stroke shown above are subject to change depending on dimensions of mold and T-slot.
- Weight varies according to the dimension of clamp T-leg and mold plate thickness h.
- Refer to page → 67 for the details of cutout dimensions on mold.

- Long stroke type
- The max. **5mm** (in case of using a lever spacer, max. **15mm**) of dimensional variation can be absorbed.



model **TYB**

■ Model designation **TYB 040**

■ Option

Refer to page → 34

1 Clamping force

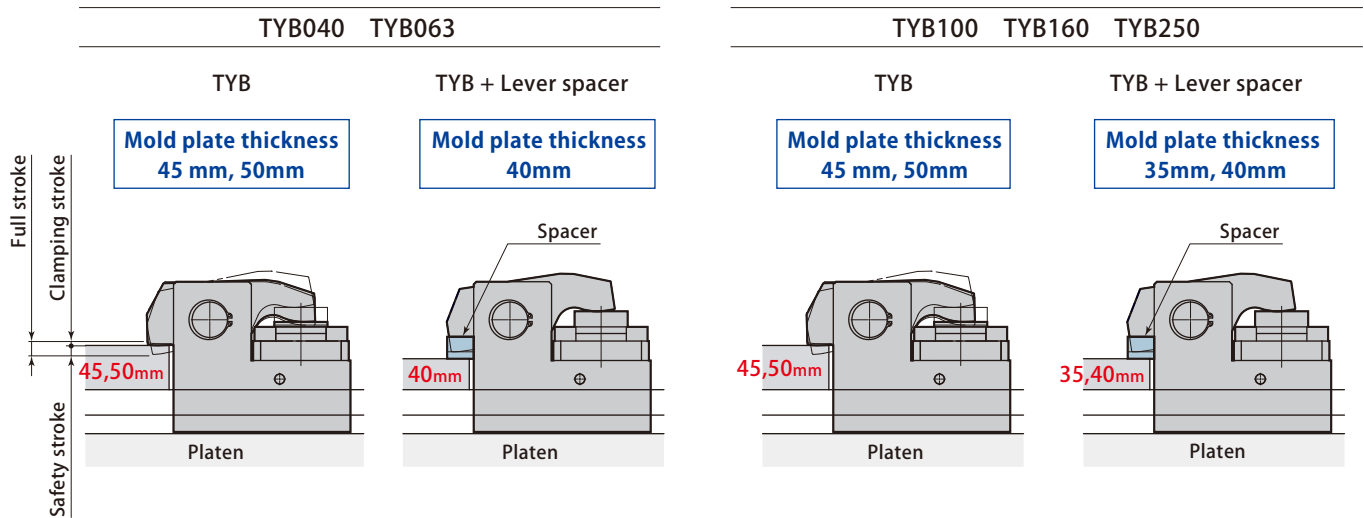

TYB + Lever spacer

- In case that the dimensional variation of mold plate thickness is over -10mm, add the lever spacer.

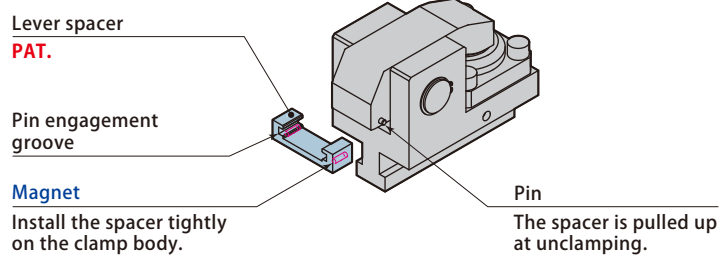

1 Specifications

Model		TYB040	TYB063	TYB100	TYB160	TYB250
Clamping force (at 24.5 MPa)	kN	39.2	61.7	98.0	156	245
Full stroke	mm	10	10	12	12	12
Clamping stroke	mm	4	4	4	4	4
Safety stroke	mm	6	6	8	8	8
Cylinder capacity (at full stroke)	cm ³	16.5	26.1	47.2	78.2	130
Proof pressure	MPa	36.7				
Working hydraulic pressure	MPa	24.5				
Operating temperature	°C	0 ~ 70 (5 ~ 120 by heat proof type)				
Weight	kg	4.5	9	15	25	45

- Safety stroke and clamping stroke shown above are subject to change depending on dimensions of mold and T-slot.
- Weight varies according to the dimension of clamp T-leg and mold plate thickness h.

- Long stroke type
- **The max.10mm** lever stroke can accommodate dimensional variation of clamping height.



model **TYJ PAT.**

■ Model designation **TYJ 063**

■ Option

Refer to page → 34

1 Clamping force

Hydraulic clamp, long stroke slidable type TYJ

Mold plate thickness 50mm

Mold plate thickness 45mm

Mold plate thickness 40mm

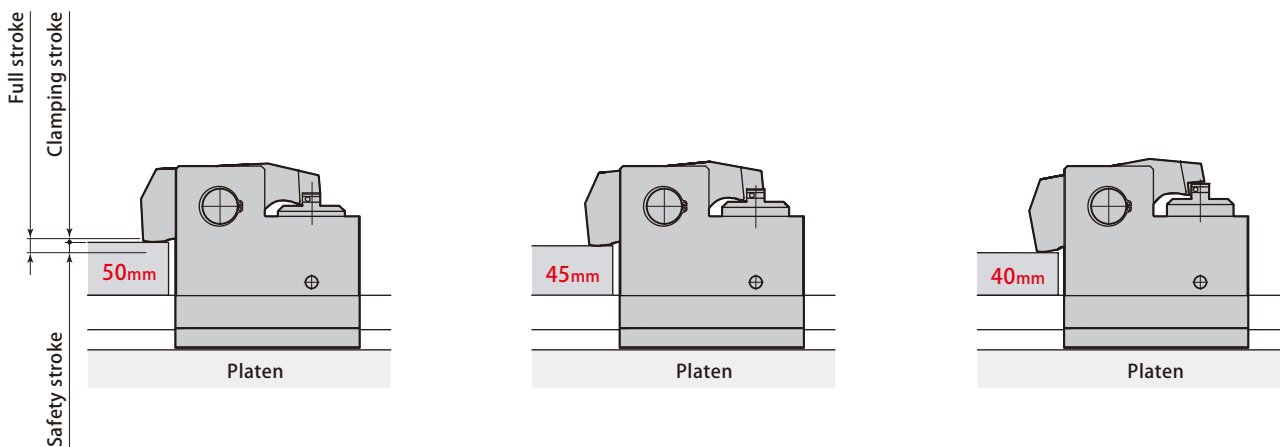

1 Specifications

Model		TYJ063	TYJ100	TYJ160	TYJ250
Clamping force (at 24.5 MPa)	kN	61.7	98	156	245
Full stroke	mm	14	15	16	16
Clamping stroke	mm	1	1	2	2
Safety stroke	mm	13	14	14	14
Cylinder capacity (at full stroke)	cm ³	34	58	97	167
Proof pressure	MPa	30.8			
Working hydraulic pressure	MPa	24.5			
Operating temperature	°C	0 ~ 70 (5 ~ 120 by heat proof type)			
Weight	kg	9	15	25	45

- Safety stroke and clamping stroke shown above are subject to change depending on dimensions of mold and T-slot.
- Weight varies according to the dimension of clamp T-leg and mold plate thickness h.

Dimensions

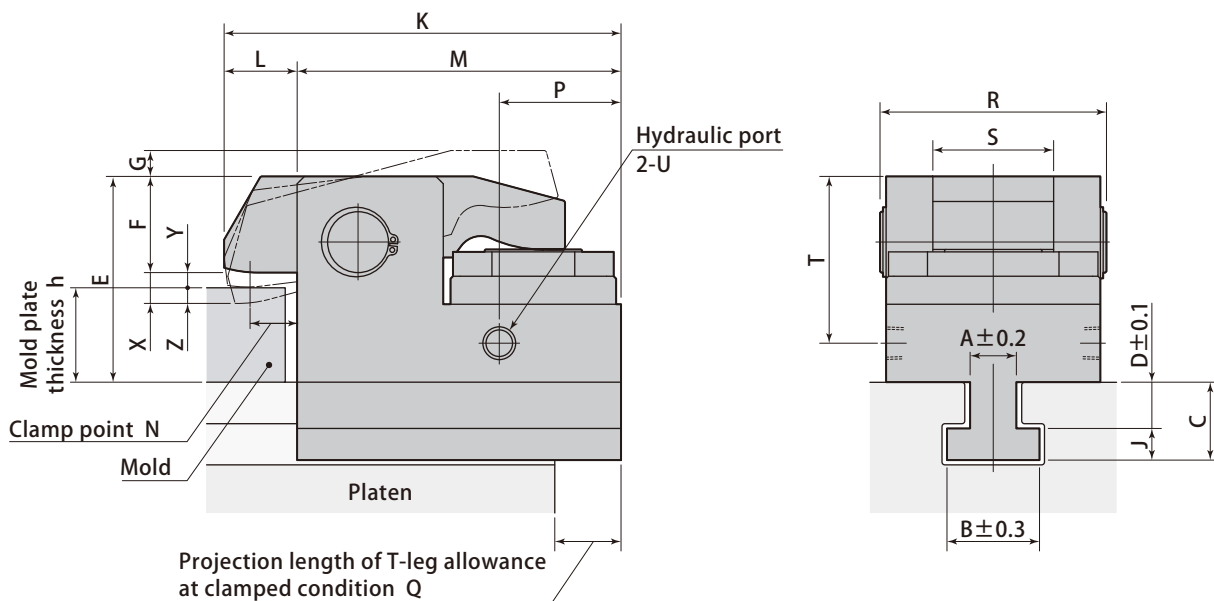

T-slot dimension and mold plate thickness

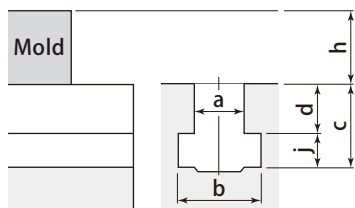

- Specify T-slot dimensions (a, b, c, d, j) and mold plate thickness (h).
- For "d" dimension of T-slot
For retrofit : Specify to 0.1 mm
For new machine : Machining tolerance shall be ±0.2 mm
- Dimensions (A, B, C, D, J) shall be determined according to T-slot dimensions.

mm

Model	TYA010	TYA020	TYA040	TYA063	TYA100	TYA160	TYA250
Height of lever F	16.5(25 ≤ h)	17.5(32.5 ≤ h)	27.5(38 ≤ h)	29.5(48 ≤ h)	45 (58 ≤ h)	60 (68 ≤ h)	76 (88 ≤ h)
range of h inside the brackets	21.5(20 ≤ h < 25)	22.5(27.5 ≤ h < 32.5)	32.5(33 ≤ h < 38)	39.5(38 ≤ h < 48)	55(48 ≤ h < 58)	70(58 ≤ h < 68)	86(78 ≤ h < 88)
	26.5(15 ≤ h < 20)	27.5(22.5 ≤ h < 27.5)	37.5(28 ≤ h < 33)	49.5(28 ≤ h < 38)	65(38 ≤ h < 48)	80(48 ≤ h < 58)	96(68 ≤ h < 78)
Max. G	6	10	10	10	11	12	13
K	73	101	143	163	195	230	270
L	15	18	23	30	30	30	30
M	58	83	120	133	165	200	240
N	10	12.5	16	20	20	20	20
P	31	41	32.5	36	62	80	90
Projection length of T-leg allowance at clamped condition Q	18	22	32	36	45	55	69
R	46.4	57.6	73	93	104	125	155
S	20	28	40	50	55	60	72
T	34.5	43	57.5	68.5	97	120	156
Hydraulic port U	Rc1/8	Rc1/4	Rc1/4	Rc1/4	Rc1/4	Rc1/4	Rc1/4
Min. E	44.5	54	69.5	81.5	107	132	168
Full stroke X	6	7	7	8	8	8	8
Clamping stroke Y	3	4	4	4	4	4	4
Safety stroke Z	3	3	3	4	4	4	4
Min. j	8	9.5	11.5	15	17	20	23
h (Min. ~ Max.)	15 ~ 50	22.5 ~ 50	28 ~ 50	28 ~ 60	38 ~ 70	48 ~ 80	68 ~ 80
Min. a	10	12.5	15	19	23	27	32
Min. C	15	25.5	32.5	35.5	32	34	30

- When newly machining T-slot, it is recommended to apply the dimensions specified on [page → 67](#).
- Height of lever F varies according to the dimension of h.
- In case of smaller than the minimum h dimension or the minimum C dimension, it is **Clamp lever low distance type**.
- In case of larger than the maximum h dimension, it is **Clamp lever high distance type**.
- Depending on T-slot dimension, TYA can be used more than maximum Q. Contact Pascal for the details.

Dimensions

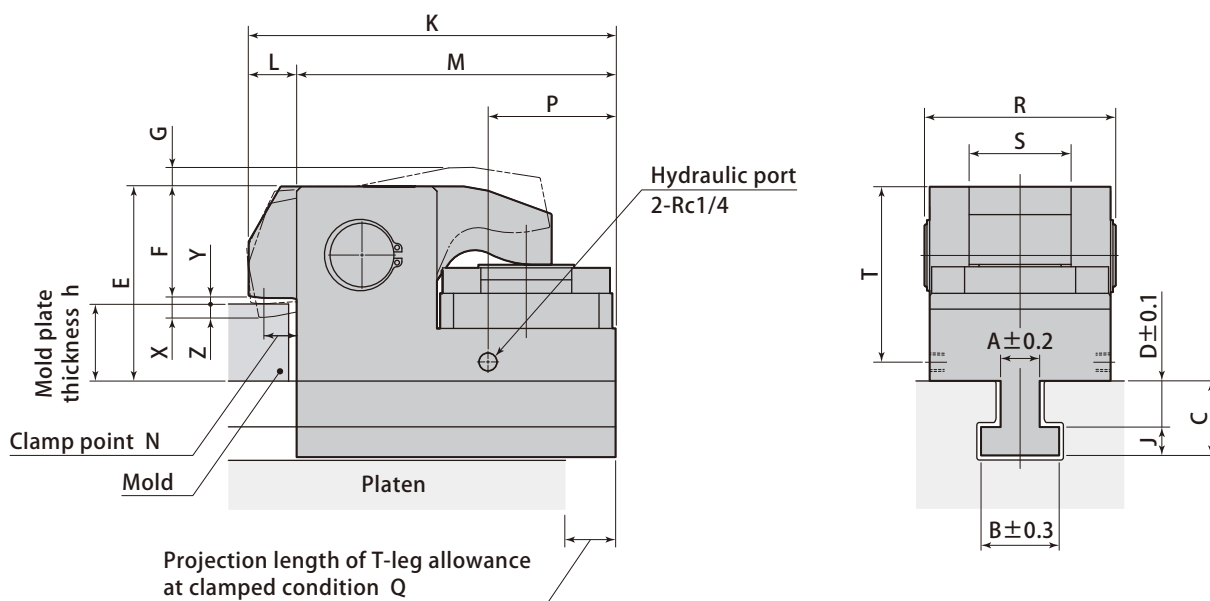

T-slot dimension and mold plate thickness

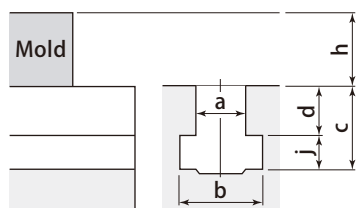

- Specify T-slot dimensions (a, b, c, d, j) and mold plate thickness (h).
- For "d" dimension of T-slot
For retrofit : Specify to 0.1 mm
For new machine : Machining tolerance shall be ± 0.2 mm
- Dimensions (A, B, C, D, J) shall be determined according to T-slot dimensions.

Model	TYB040	TYB063	TYB100	TYB160	TYB250
Height of lever F range of h inside the brackets	27.5 ($45 \leq h$)	29.5 ($50 \leq h$)	45 ($58 \leq h$)	60 ($58 \leq h$)	106 ($58 \leq h$)
	32.5 ($40 \leq h < 45$)	39.5 ($40 \leq h < 50$)	55 ($48 \leq h < 58$)	70 ($48 \leq h < 58$)	116 ($48 \leq h < 58$)
	37.5 ($35 \leq h < 40$)	49.5 ($30 \leq h < 40$)	65 ($38 \leq h < 48$)	80 ($38 \leq h < 48$)	126 ($38 \leq h < 48$)
Max. G	10	10	11	12	16
K	143	163	195	230	280
L	23	30	30	30	35
M	120	133	165	200	245
N	16	20	20	20	20
P	32.5	38	62	80	95
Projection length of T-leg allowance at clamped condition Q	32	36	45	55	65
R	73	93	104	125	155
S	40	50	55	60	72
T	64.5	71.5	94.5	110	156
Min. E	76.5	83.5	107	122	168
Full stroke X	10	10	12	12	12
Clamping stroke Y	4	4	4	4	4
Safety stroke Z	6	6	8	8	8
Min. j	11.5	15	17	20	27
h (Min. ~ Max.)	35 ~ 50	30 ~ 60	38 ~ 70	38 ~ 70	38 ~ 70
Min. a	15	19	23	27	32
Min. C	17.1	23.1	27	39	35

● When newly machining T-slot, it is recommended to apply the dimensions specified on **page → 67**. ● Height of lever F varies according to the dimension of h. ● In case of smaller than the minimum h dimension or the minimum C dimension, it is **Clamp lever low distance type**. ● In case of larger than the maximum h dimension, it is **Clamp lever high distance type**. ● Depending on T-slot dimension, TYA can be used more than maximum Q. Contact Pascal for the details.

Dimensions

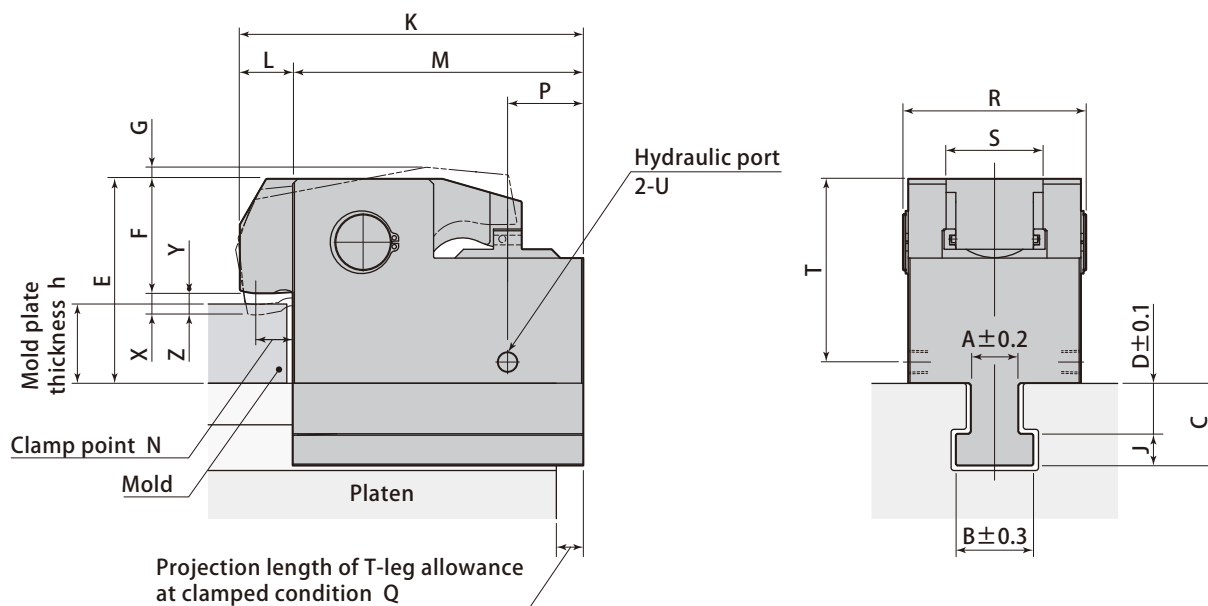

T-slot dimension and mold plate thickness

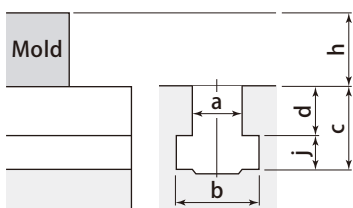

- Specify T-slot dimensions (a, b, c, d, j) and mold plate thickness (h).
- For "d" dimension of T-slot
For retrofit : Specify to 0.1 mm
For new machine : Machining tolerance shall be ±0.2 mm
- Dimensions (A, B, C, D, J) shall be determined according to T-slot dimensions.

Model	TYJ063	TYJ100	TYJ160	TYJ250
Height of lever F range of h inside the brackets	39.5 (50 ≤ h)	55 (60 ≤ h)	70 (60 ≤ h)	96 (65 ≤ h)
	49.5 (40 ≤ h < 50)	65 (50 ≤ h < 60)	80 (50 ≤ h < 60)	106 (55 ≤ h < 65)
	59.5 (30 ≤ h < 40)	75 (40 ≤ h < 50)	90 (40 ≤ h < 50)	116 (45 ≤ h < 55)
Max. G	10	10	11	15
K	163	195	232	275
L	30	30	32	35
M	133	165	200	240
N	18	20	20	22
P	34	43	53	63
Projection length of T-leg allowance at clamped condition Q	34	43	53	63
R	93	104	125	155
S	50	55	60	72
T	78.5	104	120	146
Hydraulic port U	Rc1/4	Rc1/4	Rc1/4	Rc1/4
Min. E	90.5	116	132	163
Full stroke X	14	15	16	16
Clamping stroke Y	1	1	2	2
Safety stroke Z	13	14	14	14
Min. j	15	17	20	27
h (Min. ~ Max.)	30 ~ 60	40 ~ 70	40 ~ 80	45 ~ 85
Min. a	19	23	27	32

mm

- When newly machining T-slot, it is recommended to apply the dimensions specified on **page → 67**.
- Height of lever F varies according to the dimension of h.
- In case of smaller than the minimum h dimension, it is **Clamp lever low distance type**.
- In case of larger than the maximum h dimension, it is **Clamp lever high distance type**.
- Depending on T-slot dimension, TYA can be used more than maximum Q. Contact Pascal for the details.

TYA / TYB / TYJ

G With handle TYA□-G

Only TYA040 ~ 250.
It does not correspond to TYA010 and TYA020.

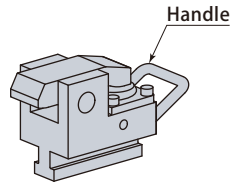

E With mold detection proximity switch

TYA□E0, E1, E2, E3

It prevents clamp misplace.

TYA□E0 : DC24V 2-Wire
TYA□E1 : DC24V 3-Wire (NPN)
TYA□E2 : AC100V 2-Wire
TYA□E3 : DC24V 3-Wire (PNP)

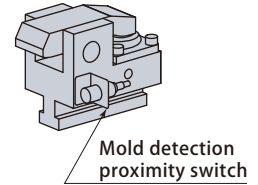

W Wide lever type TYA□-W

It is applied with cut out in the mold.

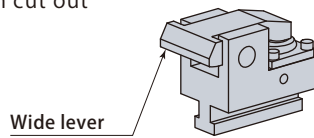

S1 S2 Body strengthened TYA□-S1, TYA□-S2

It is applied under condition that the T-slot dimension is under standard and the strength is insufficient.

TYA□-S1 : S45C
TYA□-S2 : SCM435

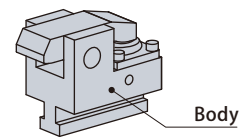

V Heat proof type TYA□-V

It is applied under condition that the mold and its surroundings are in high temperature.

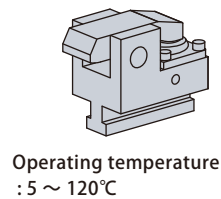

T Low distance clamp type TYA□-T

It is applied under condition that the mold plate thickness is thinner than standard.

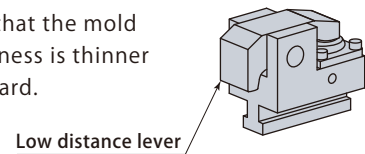

J Rear piping type TYA□-J

It is applied under condition that there is interference on clamp side and it can not be connected with side hydraulic port (standard specification).

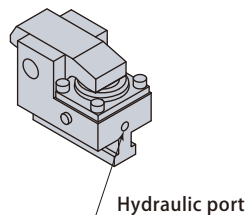

N NPT port TYA□-N

It is applied under condition that hydraulic port is connected with NPT thread.

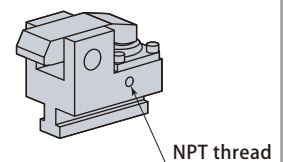

L With lock TYA□-L

It can fix the clamp installed on the position out of reach, such as the opposite operation side.

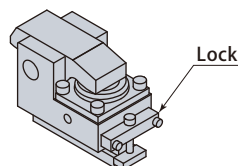

U With mold detection and backward end detection proximity switches

TYA□U0, U1, U2, U3

They prevent clamp misplace at time of mold changing.

TYA□U0 : DC24V 2-Wire
TYA□U1 : DC24V 3-Wire (NPN)
TYA□U2 : AC100V 2-Wire
TYA□U3 : DC24V 3-Wire (PNP)

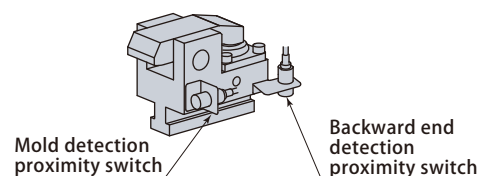

* Option model No. is available for TYB and TYJ.

Automatic slidable clamp with air cylinder. It enables to shorten the mold change time.

Hydraulic clamp, automatic slidable type **TYC-Z/R**

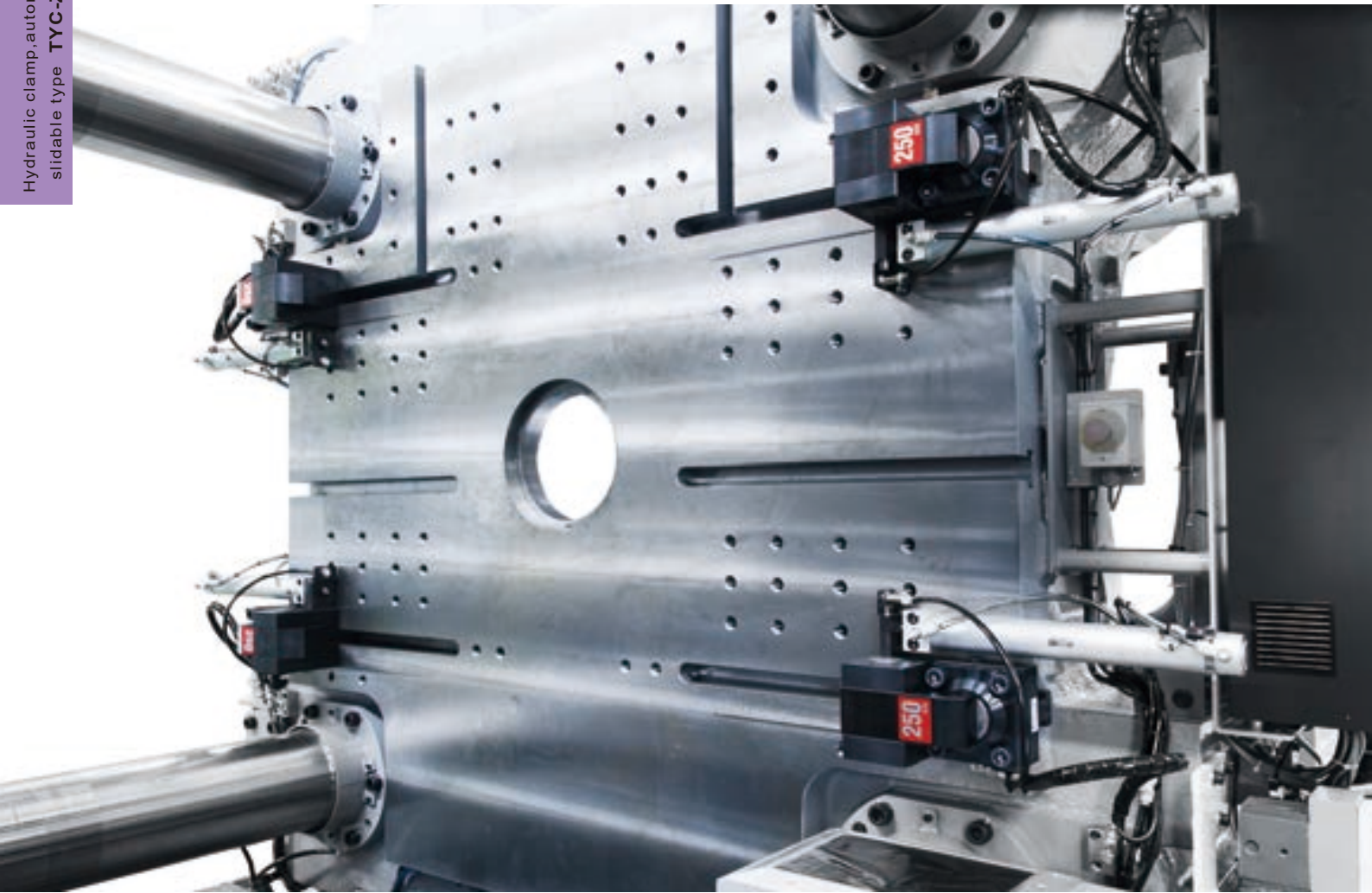

16,000kN (1,600ton) IMM vertical loading Hydraulic clamp, automatic slidable type TYC-Z



model **TYC-Z/R**

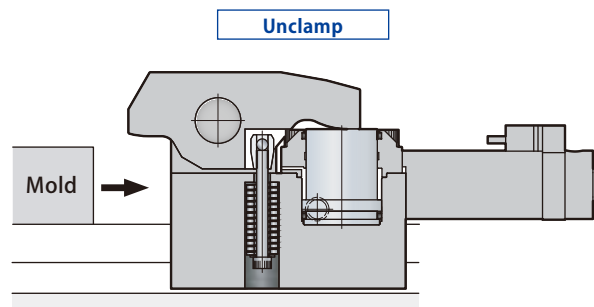
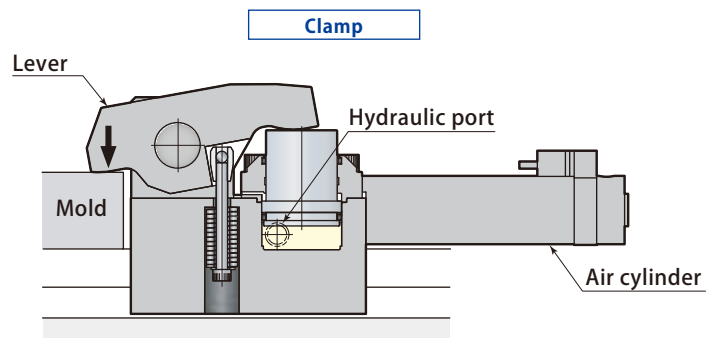

It slides automatically with an air cylinder.

TYC-Z & Die setter

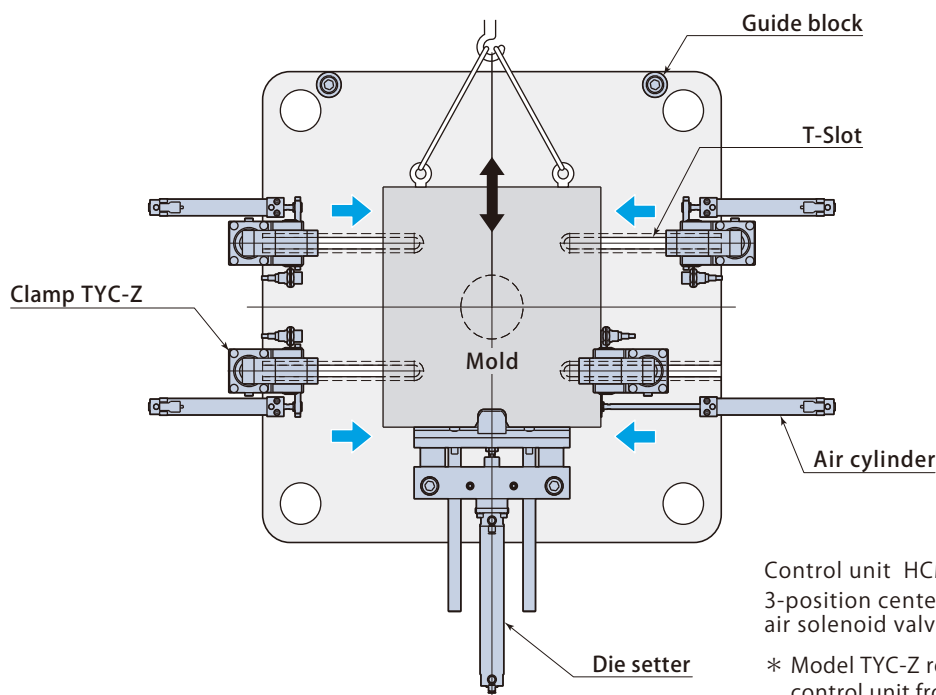

Control unit HCM-T3:
3-position center exhaust
air solenoid valve equipped

* Model TYC-Z requires a different
control unit from that of TYC-R.

■ Model designation **TYC040R0L-075**

- 1 Clamping force
- 6 Slide direction
Z :Horizontal **R** :Vertical
- 2 Proximity switch symbol
page → 38
- 3 Air cylinder position
- 5 Sliding stroke (mm)
* Indicated in 3 digits

3 Air cylinder position

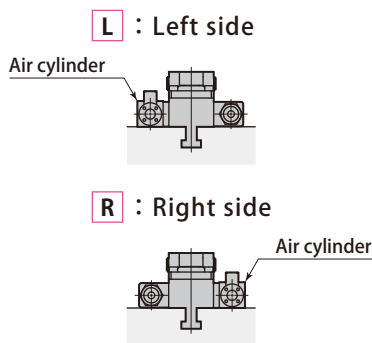

■ Option

- J** Rear piping type
- S1** Body strengthened (S45C)
- S2** Body strengthened (SCM435)
- T** Low distance clamp type
- V** Heat proof type
- W** Wide lever type
- Long stroke slidable type hydraulic clamp**
model **TYB-Z/R** model **TYJ-Z/R**

1 5 Specifications

Model		TYC020Z	TYC040Z	TYC063Z	TYC100Z	TYC160Z	TYC250Z
		TYC020R	TYC040R	TYC063R	TYC100R	TYC160R	TYC250R
Clamping force (at 24.5 MPa)	kN	19.6	39.2	61.7	98	156	245
Full stroke	mm	7	7	8	8	8	8
Clamping stroke	mm	4	4	4	4	4	4
Safety stroke	mm	3	3	4	4	4	4
Standard sliding stroke * 1	mm	50, 75, 100, 125, 150		50, 75, 100, 125, 150, 200	50, 75, 100, 125, 150, 200, 250, 300		
Slider driving air pressure	MPa	0.39 ~ 0.54					
Clamp sliding speed	mm/s	30 ~ 80 (Adjusted by speed controller)					
Proof pressure	MPa	20.5					
Working hydraulic pressure	MPa	24.5					
Operating temperature	°C	0 ~ 70 (5 ~ 120 by heat proof type *2)					
Weight	kg	3.5	5	10	16	26	38

● Weight varies according to the dimension of clamp T-leg and mold plate thickness h. ● Refer to page → 67 for the details of cutout dimensions on mold. * 1 Contact Pascal for the sliding stroke which is not mentioned above.

* 2 Proximity switch and auto switch will not become a heat proof type.

Hydraulic clamp, automatic slidable type **TYC-Z/R**

Dimensions

● The drawings indicate : air cylinder position **R** (Right).

Unclamp

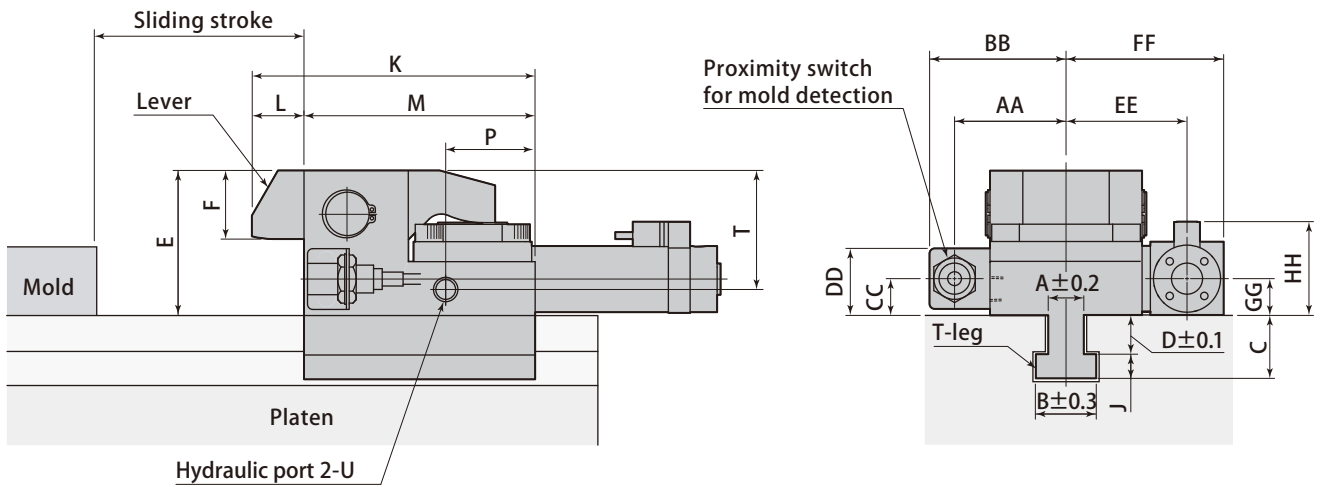
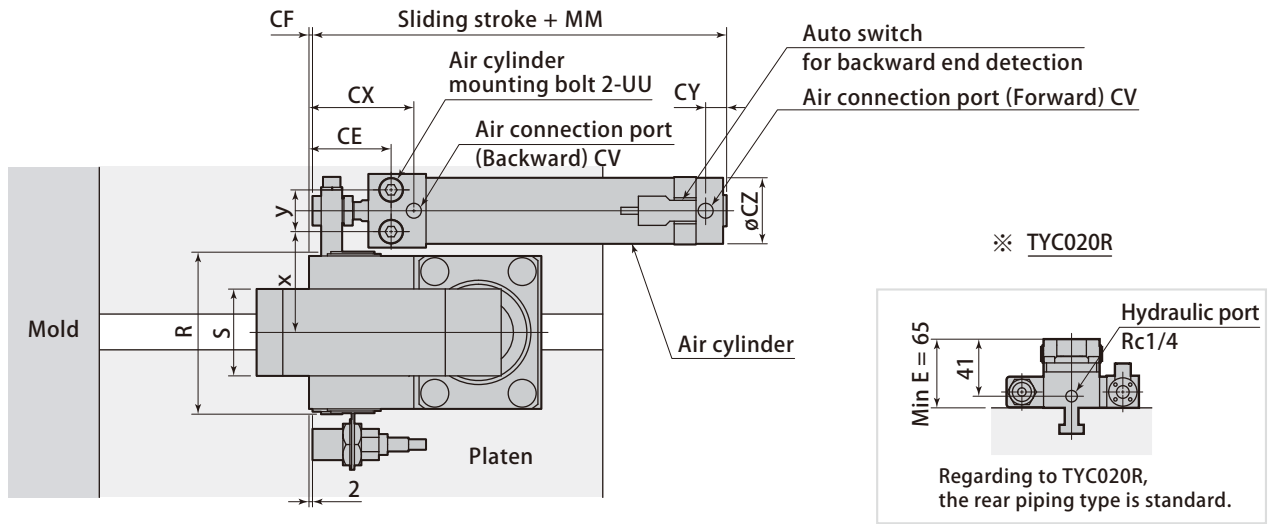

Clamp

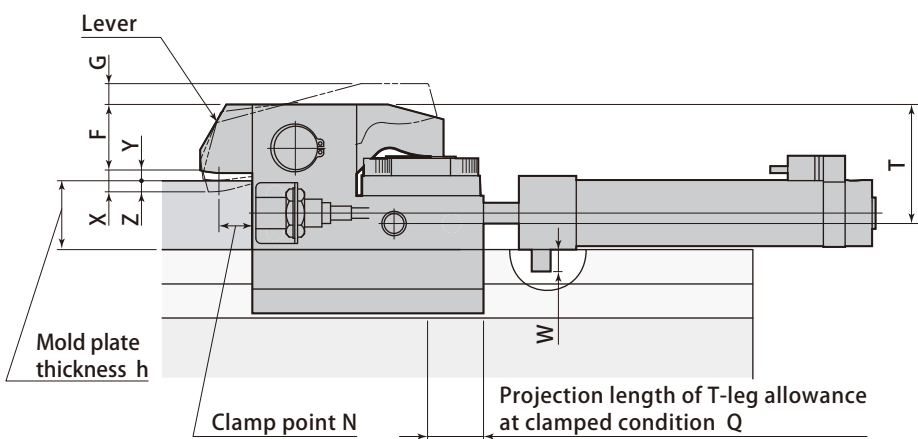

T-slot dimension and mold plate thickness

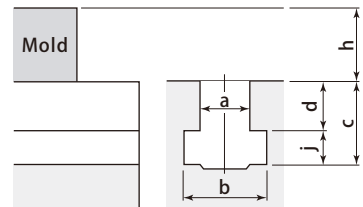

- Specify T-slot dimensions (a, b, c, d, j) and mold plate thickness (h).
- For "d" dimension of T-slot
For retrofit : Specify to 0.1 mm
For new machine : Machining tolerance shall be ±0.2 mm
- Dimensions (A, B, C, D, J) shall be determined according to T-slot dimensions.

Model	TYC020Z	TYC040Z	TYC063Z	TYC100Z	TYC160Z	TYC250Z
	TYC020R	TYC040R	TYC063R	TYC100R	TYC160R	TYC250R
AA	47	54.5	64.5	74	84	98.5
BB	61.5	69	79	89	99	113.5
CC	15	15	21	26	26	32
CE	42.5	42.5	47	57	57	71
CF	2.5	2.5	2	2	2	9
Air connection port CV	Rc1/8	Rc1/8	Rc1/8	Rc1/8	Rc1/8	Rc1/4
CX	51.5	51.5	60	71	71	87
CY	12	12	12	12	12	14
CZ	26	26	38	47	47	58
DD	29.5	29.5	38.5	51	51	63
Min. E	—	69.5	81.5	107	132	168
EE	48.5	56	70	81	91	116
Height of lever F range of h inside the brackets	17.5(32.5≤h)	27.5(38≤h)	29.5(48≤h)	45(58≤h)	60(68≤h)	76(88≤h)
	22.5(27.5≤h<32.5)	32.5(33≤h<38)	39.5(38≤h<48)	55(48≤h<58)	70(58≤h<68)	86(78≤h<88)
	27.5(22.5≤h<27.5)	37.5(28≤h<33)	49.5(28≤h<38)	65(38≤h<48)	80(48≤h<58)	96(68≤h<78)
FF	64.6	72.1	89.5	109	119	153
Max. G	10	10	10	11	12	13
GG	15	15	21	26	26	32
HH	42	42	54	63	63	74
K	101	143	163	195	230	270
L	18	23	30	30	30	30
M	83	120	133	165	200	240
Standard sliding stroke	50, 75, 100, 125, 150		50, 75, 100, 125, 150, 200	50, 75, 100, 125, 150, 200, 250, 300		
MM	108.5	108.5	119	137	137	164
N	12.5	16	20	20	20	20
P	—	32.5	36	62	80	90
Projection length of T-leg allowance at clamped condition Q	22	32	36	45	55	69
R	57.6	73	93	104	125	155
S	28	40	50	55	60	72
T	—	57.5	68.5	97	120	156
Hydraulic port U	—	Rc1/4	Rc1/4	Rc1/4	Rc1/4	Rc1/4
UU	M5	M5	M8	M10	M10	M12
W	9.5	9.5	9.6	12.6	12.6	17
x	39.5	47	58	65	75	95.5
y	18	18	24	32	32	41
Full stroke X	7	7	8	8	8	8
Clamping stroke Y	4	4	4	4	4	4
Safety stroke Z	3	3	4	4	4	4
Min. a	12.5	15	19	23	27	32
Min. j	9.5	11.5	15	17	20	23
h (Min. ~ Max.)	22.5 ~ 50	28 ~ 50	28 ~ 60	38 ~ 70	48 ~ 80	68 ~ 80

Hydraulic clamp, automatic slidable type TYC-Z/R

- When newly machining T-slot, it is recommended to apply the dimensions specified on **page → 67**.
- Height of lever F varies according to the dimension of h.
- In case of smaller than the minimum h dimension, it is **Clamp lever low distance type**.
- In case of larger than the maximum h dimension, it is **Clamp lever high distance type**.
- The position of hydraulic port is subject to change.
- Body height E is subject to change.
- Contact Pascal for the sliding stroke which is not mentioned above.

2 Proximity switch (OMRON)

Proximity switch symbol	0	1	2	3
Switch model	2-Wire DC	3-Wire DC	2-Wire AC	3-Wire DC
	E2E-X7D1-N	E2E-X5E1	E2E-X5Y1	E2E-X5F1
Supply voltage V	DC10 ~ 30	DC10 ~ 40	AC20 ~ 264	DC10 ~ 40
Leakage current mA	0.8 and under	No	1.7 and under	No
Current consumption mA	No	13 and under	No	13 and under
Control output (Switching capacity) mA	3 ~ 100	200	5 ~ 300	200

- Operating temperature : 0 ~ 70°C
- Insulation vinyl cable length : 5m (Oil proof type, 0.5mm²)
- When using Pascal control box, 3-wire DC type (1) shall be delivered.

Auto switch (SMC)

Switch model	D-B54L		
Load voltage V	DC24	AC100	AC200
Range of load current mA	5 ~ 50	5 ~ 25	5 ~ 12.5

- Operating temperature : 0 ~ 70°C
- Insulation vinyl cable length : 3m (Oil proof type, 0.3mm²)

TYA-M

Hydraulic clamp, T-slot-less slidable type

It enables the clamp to slide it manually even if machine platens do not have T-slots.

Hydraulic clamp, T-slot-less slidable type TYA-M

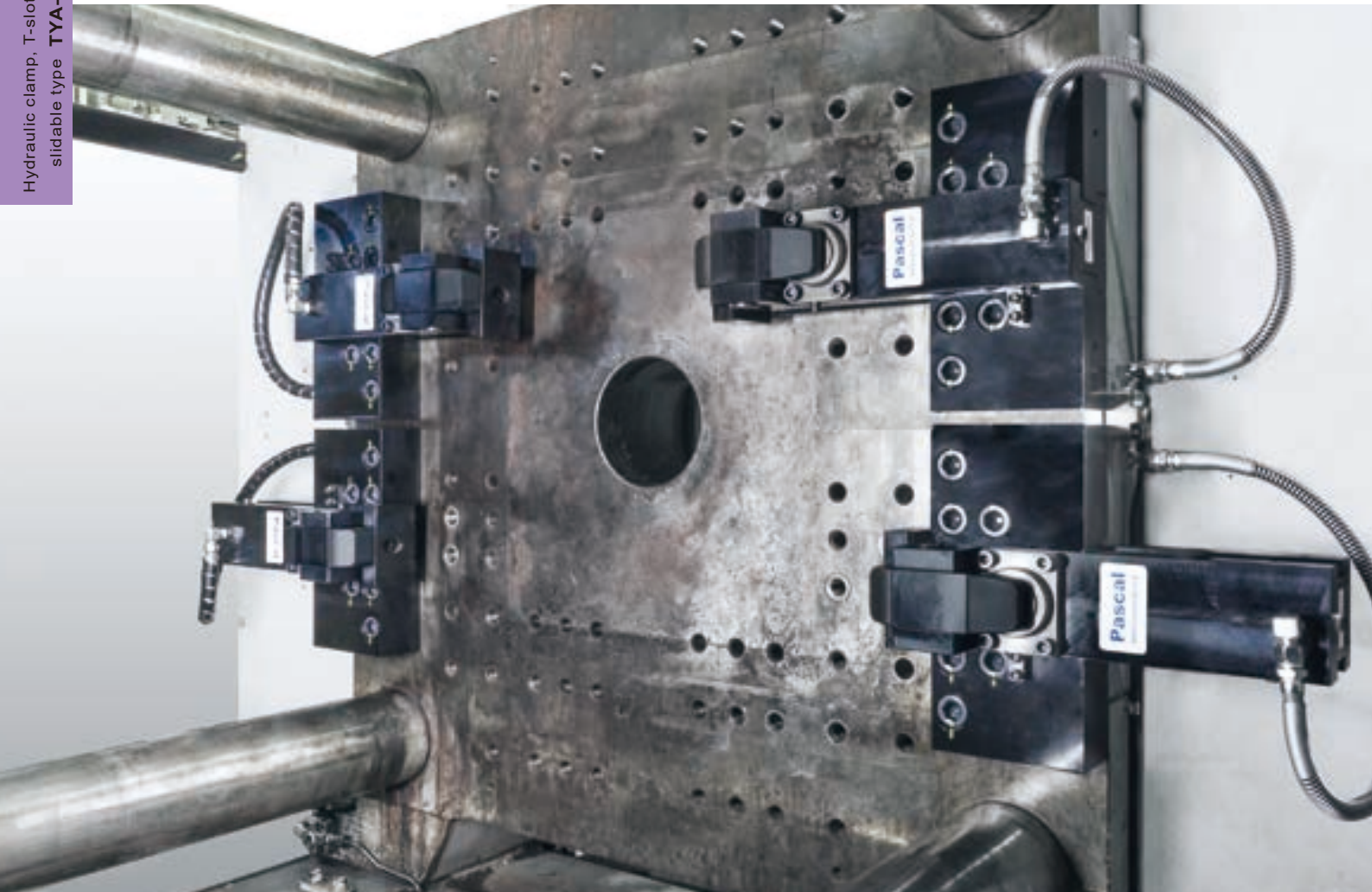

3,500kN (350ton) IMM vertical loading Hydraulic clamp, T-slot-less slidable type TYA-M



model **TYA-M**

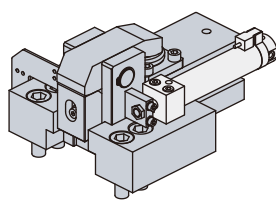

There is also an automatic slidable model with an air cylinder. Please contact Pascal for the details.

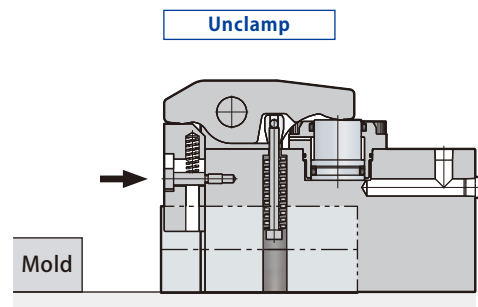
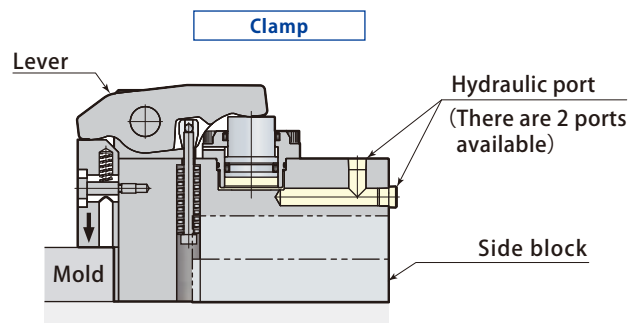

Forward and backward of the clamp itself is manual.

TYA-M & Die setter

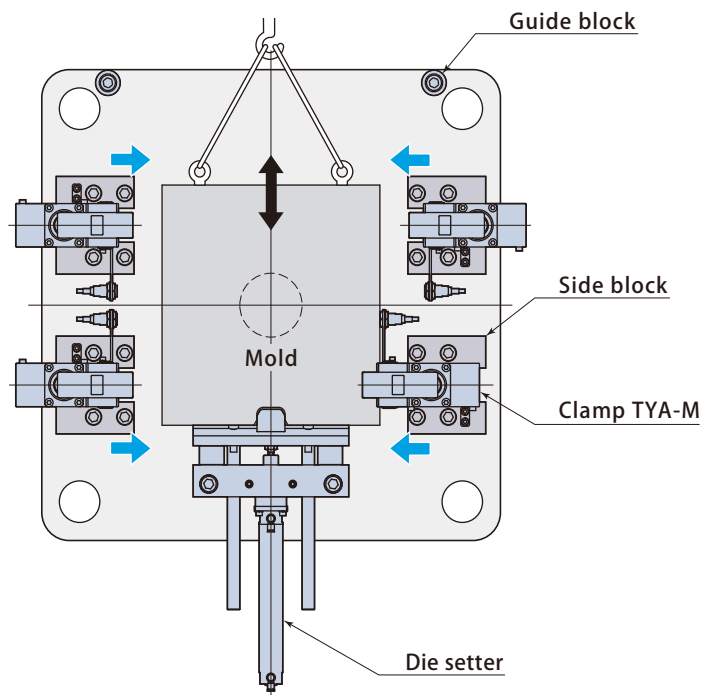

■ Model designation **TYA 040M**

1 Clamping force

■ Option

- 0 ~ 3 With mold detection proximity switch
- G With handle
- S1 Body strengthened (S45C)
- S2 Body strengthened (SCM435)
- V Heat proof type
- T Low distance clamp type
- W Wide lever type

1 Specifications

Model		TYA010M	TYA020M	TYA040M	TYA063M	TYA100M	TYA160M
Clamping force (at 24.5 MPa)	kN	9.8	19.6	39.2	61.7	98	156
Full stroke	mm	6	7	7	8	8	8
Clamping stroke	mm	3	4	4	4	4	4
Safety stroke	mm	3	3	3	4	4	4
Cylinder capacity (at full stroke)	cm ³	2.4	6.3	13.2	22.3	37	61
Standard sliding stroke	mm	12	38	50	50	65	75
Proof pressure	MPa	20.5					
Working hydraulic pressure	MPa	24.5					
Operating temperature	°C	0 ~ 70 (5 ~ 120 by heat proof type)					

- Safety stroke and clamping stroke are subject to change depending on dimensions of mold.
- Weight varies according to the dimension of clamp T-leg and side block.
- Refer to **page → 67** for the details of cutout dimensions on mold.
- If the value of sliding stroke exceeds the above table, please contact Pascal later.

Dimensions

Unclamp

Side block mounting bolt 4-UU

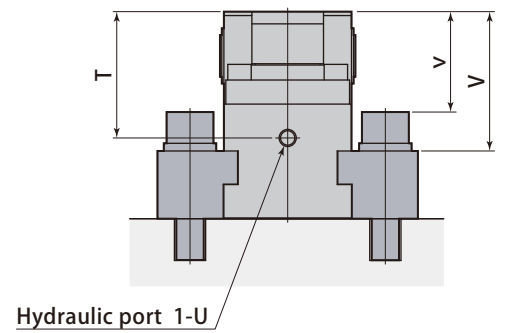
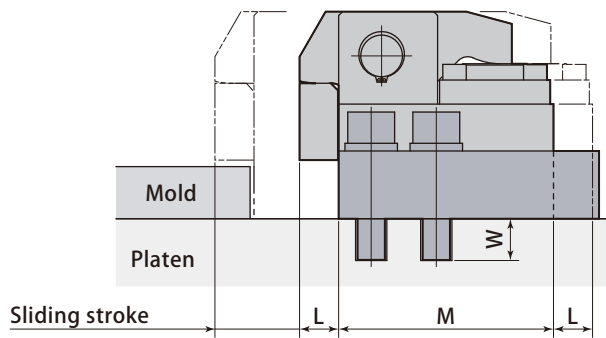
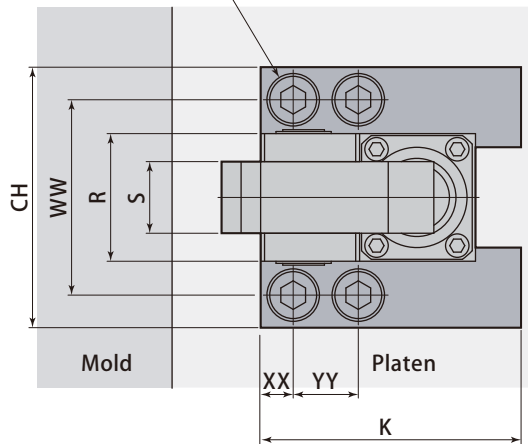

Regarding to TYA-M,
the rear piping type is standard.

Clamp

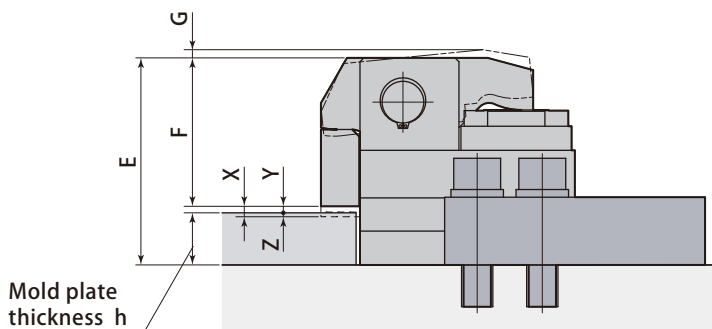

Model	TYA010M	TYA020M	TYA040M	TYA063M	TYA100M	TYA160M
CH	105	130	130	160	200	230
E (Case of standard h dimension)	63.5	86.5	106.5	123.5	159	197
F (Case of standard h dimension)	40.5	52.5	72.5	84.5	115	153
Max. G	6	10	10	10	11	12
K	70	100	135	150	200	240
L	15	18	23	30	30	30
M	63	83	120	133	165	200
R	43	53	68	88	98	118
S	20	28	40	50	55	60
T	40.5	54	68	79	97	120
Hydraulic port U	Rc1/8	Rc1/4	Rc1/4	Rc1/4	Rc1/4	Rc1/4
UU	M16 *	M16	M16	M20	M24	M30
v	26	34.5	49.5	56.4	77.1	94.5
V	45.5	54.5	69.5	81.5	107	132
W	23.5	24	24	32.9	32.1	49.1
WW	75	100	100	125	150	175
XX	23	25	25	25	25	30
YY	25	50	50	50	50	60
Standard sliding stroke	12	38	50	50	65	75
Full stroke X	6	7	7	8	8	8
Clamping stroke Y	3	4	4	4	4	4
Safety stroke Z	3	3	3	4	4	4
Standard h	20	30	30	35	40	40

- The above table is reference value. ● CH, K, WW, XX, YY varies according to the installed position of clamp.
- The dimension varies in case of **specification of mold detection prox.switch**. Please contact Pascal later.
- * TYA010M utilizes the square spring washer.

It is the clamp with safety and high reliability, which does not lose holding force because of the strong spring even at time of zero hydraulic pressure.

Hydraulic clamp, bolted type TME

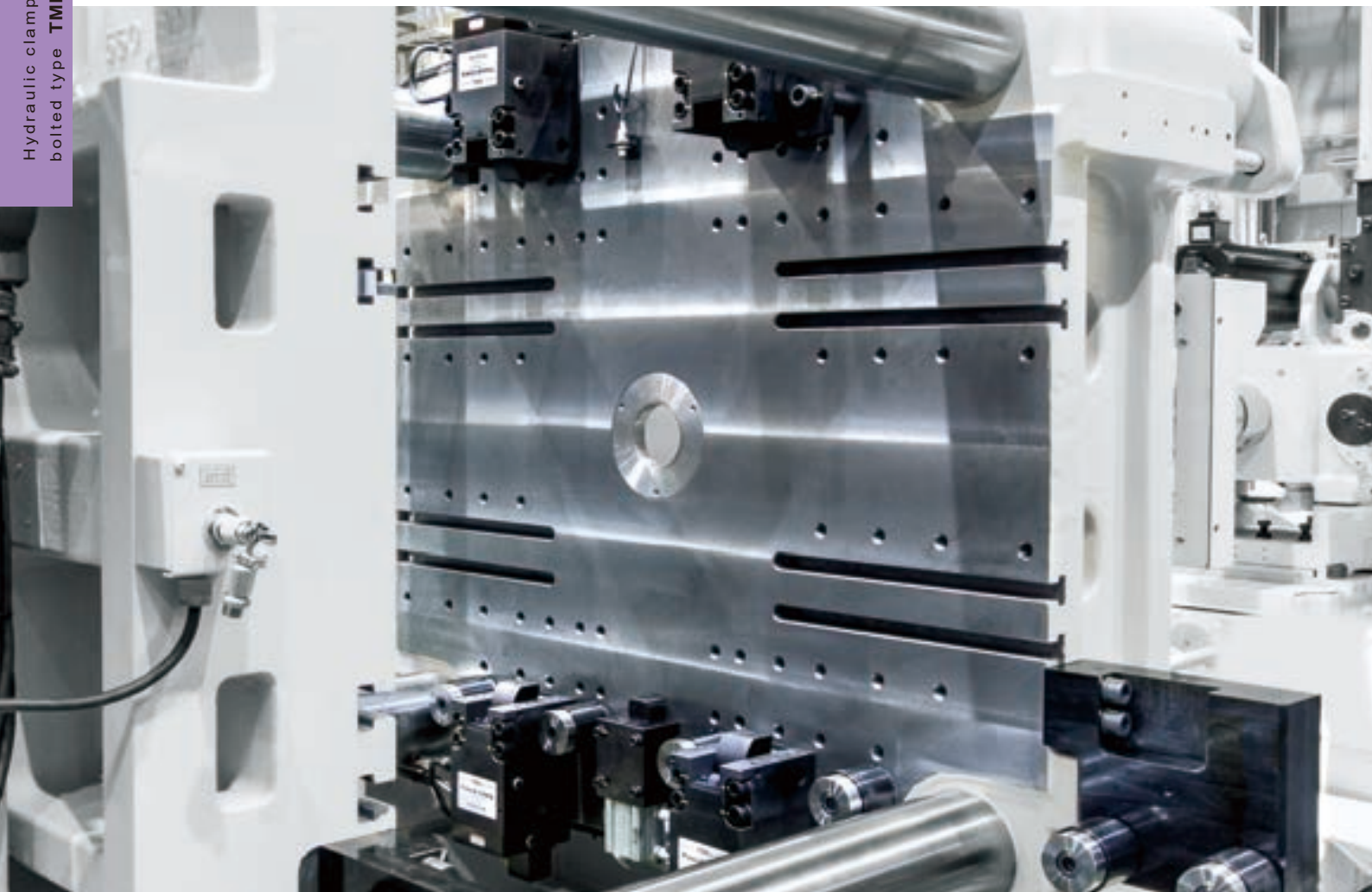

5,500kN (550ton) IMM horizontal loading Hydraulic clamp, bolted type TME



model TME

Clamp

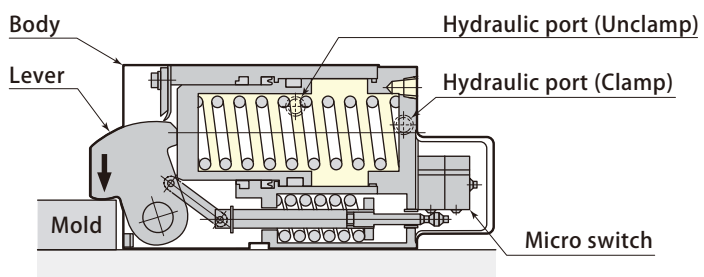

Unclamp

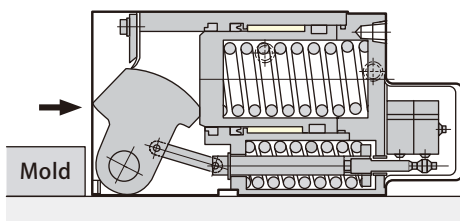

At time of unclamping, the lever is retracted back in the body and it does not interfere in loading/unloading the mold.

TME & Positioning block

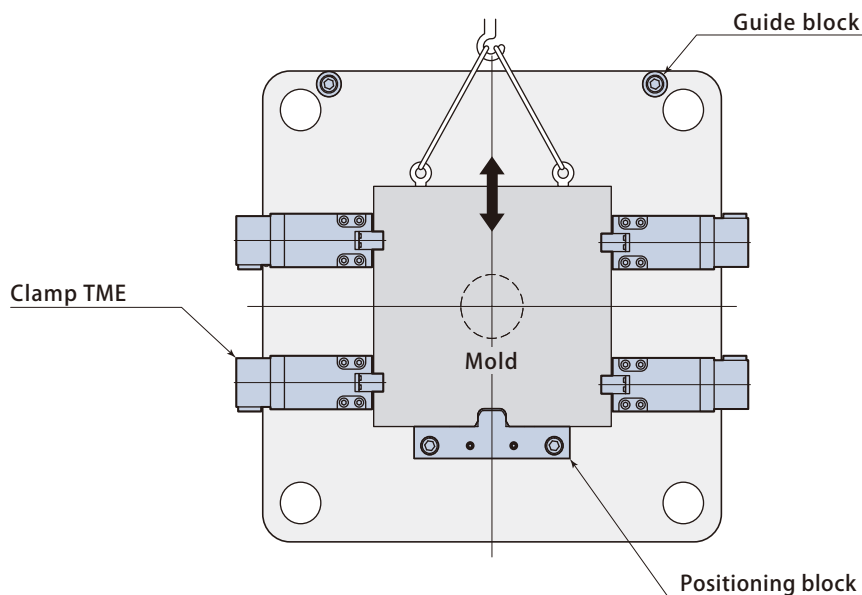

■ Model designation ■ Option

TME 025 —

- S Low distance clamp type
- V Heat proof type

- 1 Holding force
- 4 Mold plate thickness h dimension(mm) **page → 46**

Hydraulic and air pressure circuit

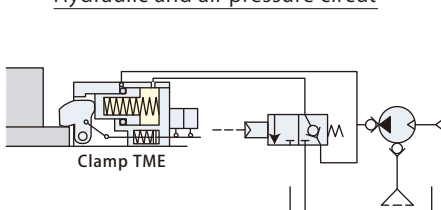

Working hydraulic pressure 15.6 MPa with Pascal non-leak valve

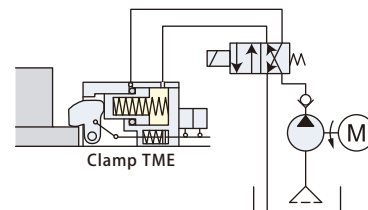

Working hydraulic pressure 13.7 MPa with commercially available valve

1 Specifications

Model		TME010	TME025	TME040	TME063	TME100	TME160	
Holding force	At working hydraulic pressure	kN	9.8	24.5	39.2	61.7	98	156
	At no hydraulic pressure (0MPa)	kN	0.49	0.98	1.56	2.45	3.92	5.88
Clamping force	At working hydraulic pressure	kN	9.8	24.5	39.2	61.7	98	156
Full stroke		mm	3.5	4	4	4	4.5	4.5
Clamping stroke		mm	2	2	2	2	2	2
Safety stroke		mm	1.5	2	2	2	2.5	2.5
Cylinder capacity	Clamp	cm ³	15	41	92	163	298	470
	Unclamp	cm ³	6	11	28	48	87	143
Proof pressure		MPa	20.5					
Working hydraulic pressure (with Pascal non-leak valve)		MPa	15.6					
Working hydraulic pressure (with commercially available valve)		MPa	13.7					
Operating temperature		°C	0 ~ 70					
Weight		kg	3	6	9	15.5	30	55

- The hydraulic pressure required to unclamp is 2.9MPa.
- Refer to **page → 67** for the details of cutout dimensions on mold.

Dimensions

TME 025 ~ 160 -

Mold plate thickness h dimension (mm)

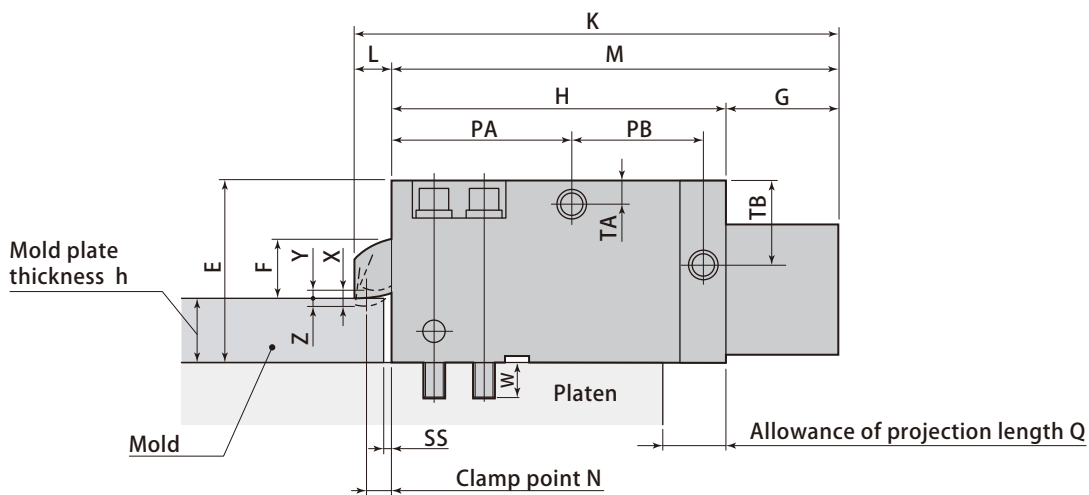
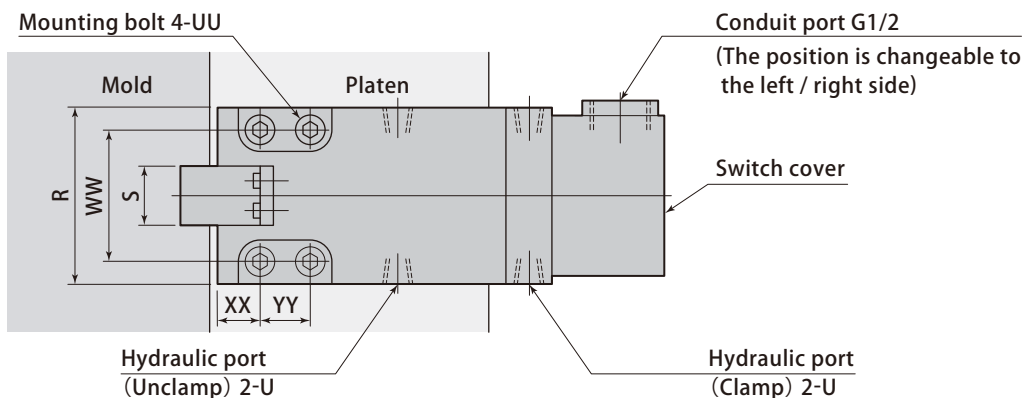

(Position installed of switch cover : left)

TME 010 L -

Mold plate thickness h dimension (mm)

(Position installed of switch cover : right)

TME 010 R -

Mold plate thickness h dimension (mm)

Append of position installed of switch cover only for TME010

Position installed of switch cover left : L right : R

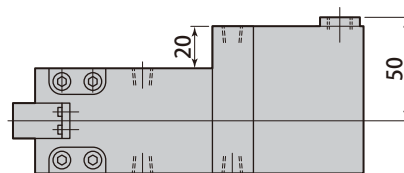
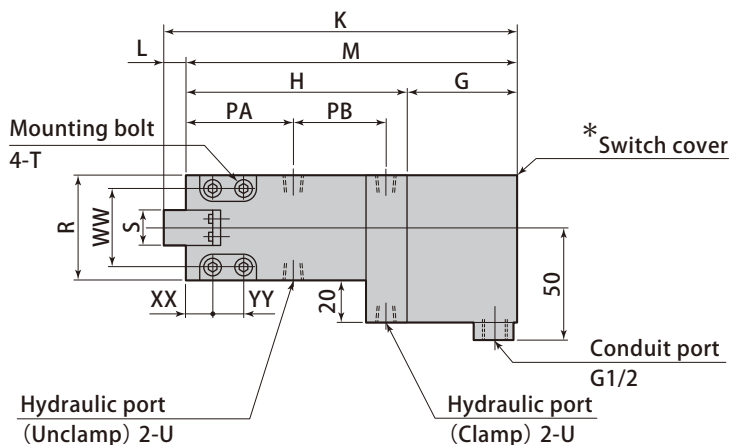

* The form of TME010 differs according to the position installed of switch cover.

	mm					
Model	TME010	TME025	TME040	TME063	TME100	TME160
Min. E	62	86	106	125	152	177
Height of lever F	21	30	39	43	57	78
G	59.5	59.5	59.5	59.5	64	68.5
H	121.5	149.5	180	197	238.5	285
K	132.5	165.5	199	218	263.5	317
L	11	16	19	21	25	32
M	181	209	239.5	256.5	302.5	353.5
N	9	12	14	15	19	20
PA	55.5	74	89	99	121	156.5
PB	56	65.5	80	86	100	108.5
Allowance of projection length Q	24	29	36	39	47	57
R	52	78	88	108	135	182
S	18	27	35	45	55	72
TA	11	15	20	24	30.5	38.5
TB	23.5	31	39	48	61	62
Hydraulic port U	Rc1/8	Rc1/4	Rc1/4	Rc1/4	Rc3/8	Rc3/8
SS	2	3	3	3	3	3
UU	M8	M10	M12	M14	M18	M24
W	17	19	22	24.5	31.4	37
WW	38	58	68	84	106	135
XX	12	17	20	22	30	40
YY	18	22	26	30	36	50
Full stroke X	3.5	4	4	4	4.5	4.5
Clamping stroke Y	2	2	2	2	2	2
Safety stroke Z	1.5	2	2	2	2.5	2.5
4 Min. h *	20	30 (25)	30 (25)	35 (30)	40 (35)	40

* The values in parentheses are for special specification.

Micro switch specifications (OMRON)

Micro switch model	Z-15GD-B	
Rated voltage	V	AC250 DC30
Rated current (Resistance load)	A	15 6

Bolted type of clamp for medium and large size IMM with lever-piston isolation structure.

Hydraulic clamp,
bolted type **TKB**

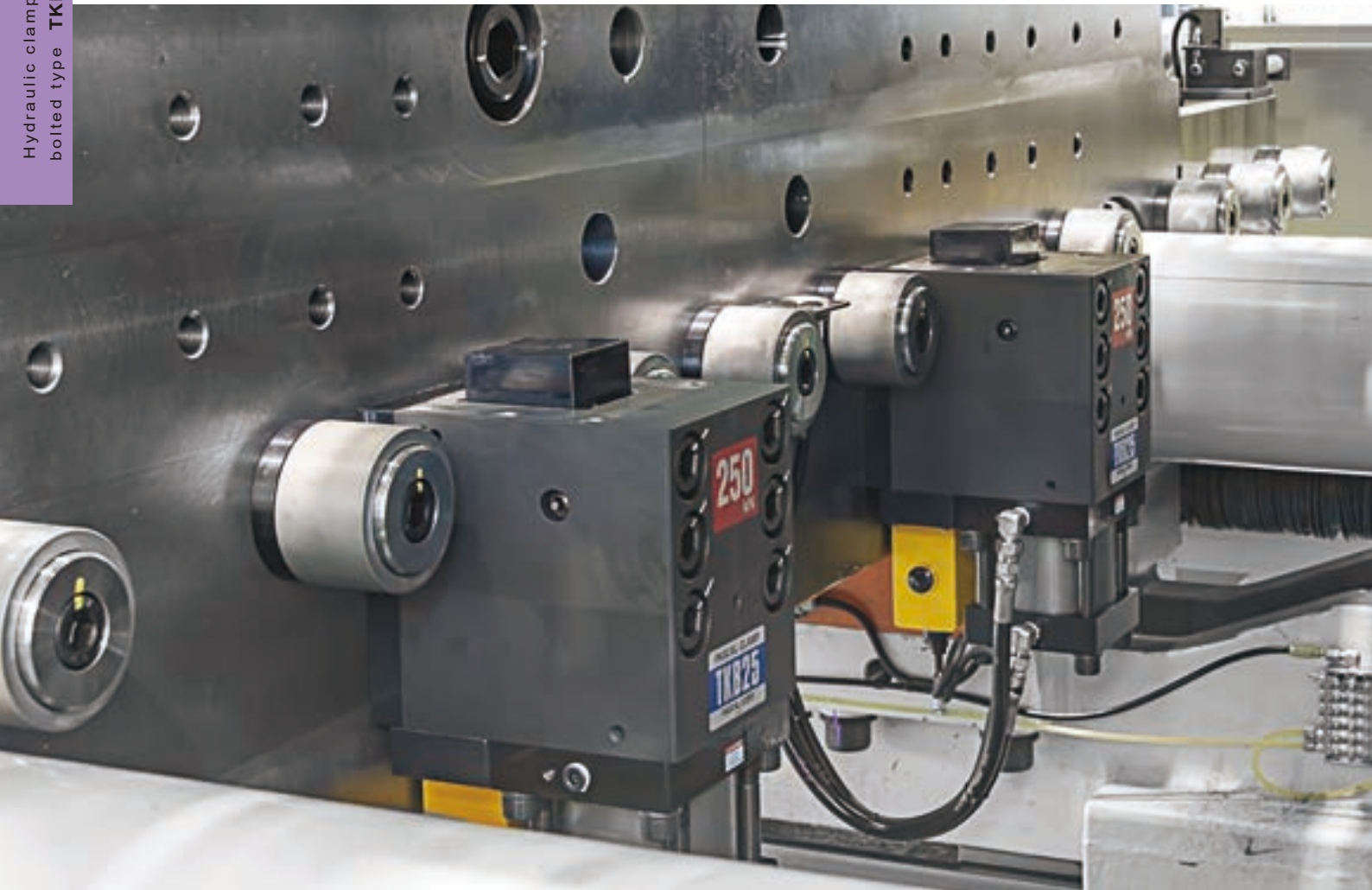

16,000kN (1,600ton) IMM horizontal loading Hydraulic clamp, bolted type TKB



model **TKB**



There is also an automatic slidable model with an air cylinder.
Contact Pascal for the details.

Clamp

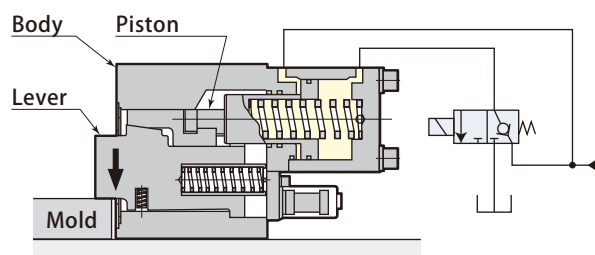

Unclamp

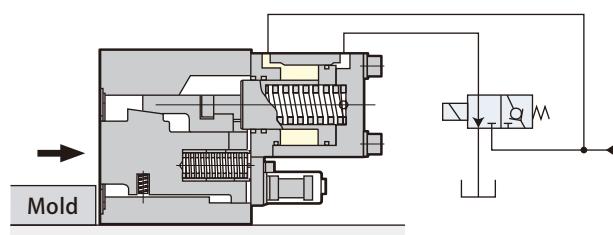

At time of unclamping, the lever is retracted back in the body and it does not interfere in loading/unloading the mold.

TKB & Positioning block

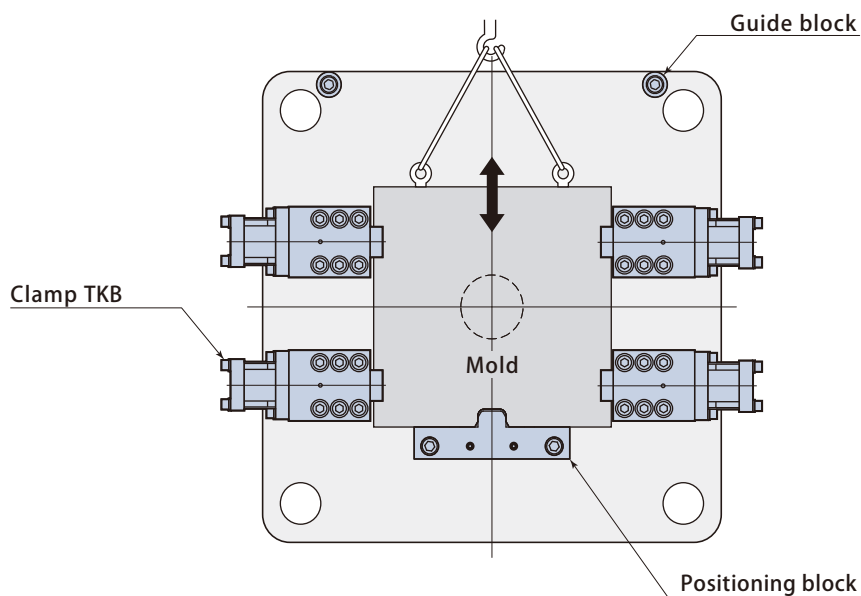

■ Model designation

TKB 160 —

1 Holding force

4 Mold plate thickness
h dimension (mm) page → 50

■ Option

S Low distance clamp type

V Heat proof type

1 Specifications

Model			TKB160	TKB250	TKB400	TKB500
Holding force	At hydraulic pressure 13.7MPa	kN	156	245	392	490
	At no hydraulic pressure (0MPa)	kN	19.6	29.4	49	88.2
Clamping force	At hydraulic pressure 13.7MPa	kN	49	78.4	137.2	176.5
Full stroke		mm	4.5	4.5	5.5	5.5
Clamping stroke		mm	2	2	2.5	2.5
Safety stroke		mm	2.5	2.5	3	3
Cylinder capacity	Clamp	cm ³	284	460	859	859
	Unclamp	cm ³	173	277	507	507
Proof pressure		MPa	20.5			
At working hydraulic pressure		MPa	13.7			
Operating temperature		°C	0 ~ 80			
Weight		kg	38	67	130	160

● Refer to page → 67 for the details of cutout dimensions on mold.

Dimensions

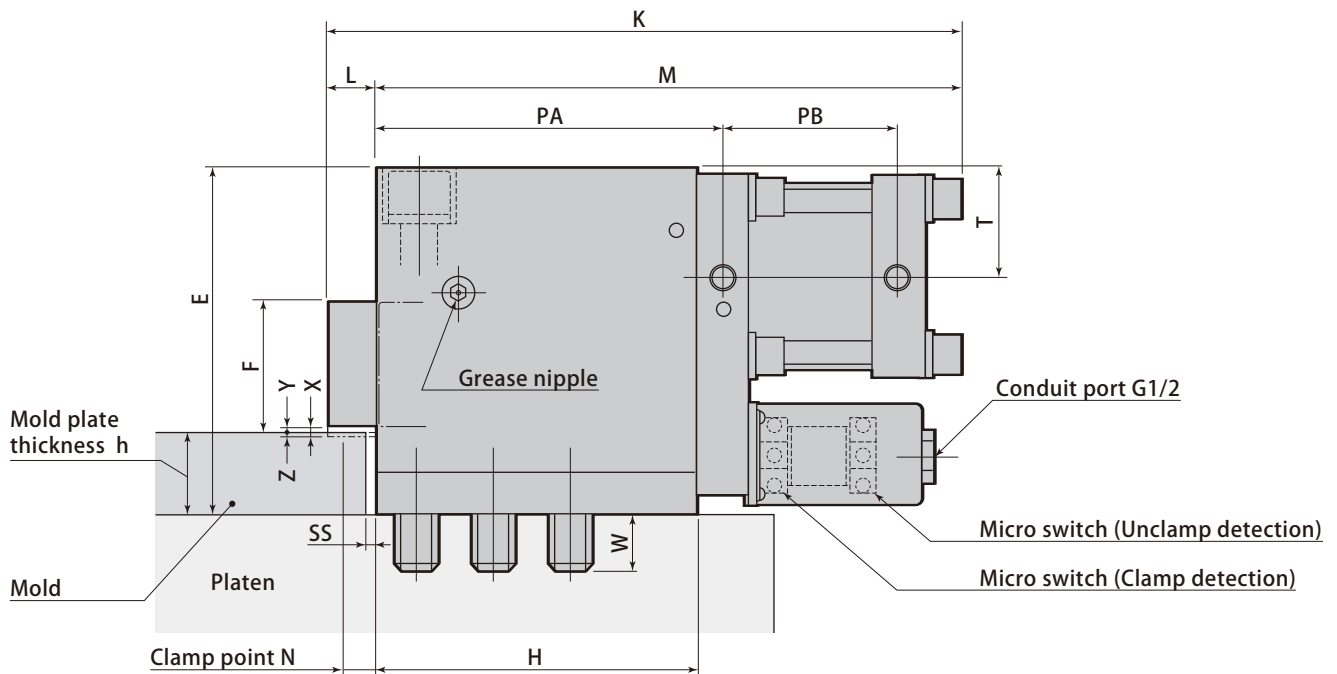
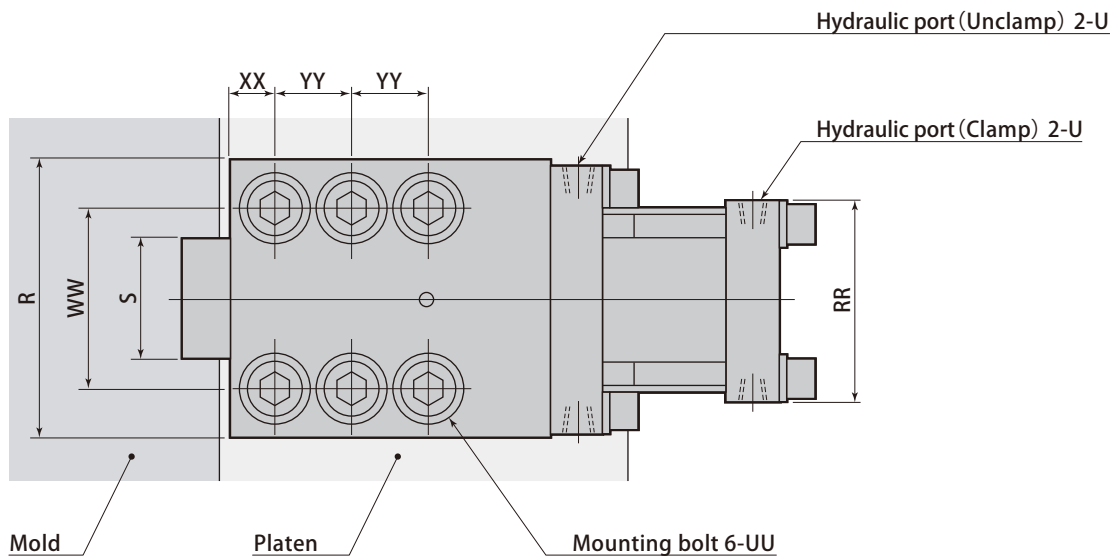

mm				
Model	TKB160	TKB250	TKB400	TKB500 (Standard)
Min. E	180	220	250	260
Height of lever F	75	82	99	99
H	165.5	204.5	242.5	292.5
K	342.9	401.2	472.1	522.1
L	32.9	32.7	38	38
M	310	368.5	434.1	484.1
N	20	20	25	25
PA	180.5	221	262	312
PB	99	110.5	129	129
R	145	175	215	215
RR	105	128	155	155
S	65	76	90	90
SS	3	3	5	5
T	58	69	81	91
Hydraulic port U	Rc3/8	Rc3/8	Rc3/8	Rc3/8
UU	M20	M24	M30	M30
W	31.4	35.6	52	52
WW	98	118	145	145
XX	22	27	32	32
YY	39	49	60	60
Full stroke X	4.5	4.5	5.5	5.5
Clamping stroke Y	2	2	2.5	2.5
Safety stroke Z	2.5	2.5	3	3
4 Min. h	40	50	50	50

Micro switch specifications (OMRON)

Micro switch model	Z-15 GD-B	
Rated voltage	V	AC250 DC30
Rated current (Resistance load)	A	15 6

Air-driven T-slotted slidable clamp.

Air clamp, slidable type
TLC

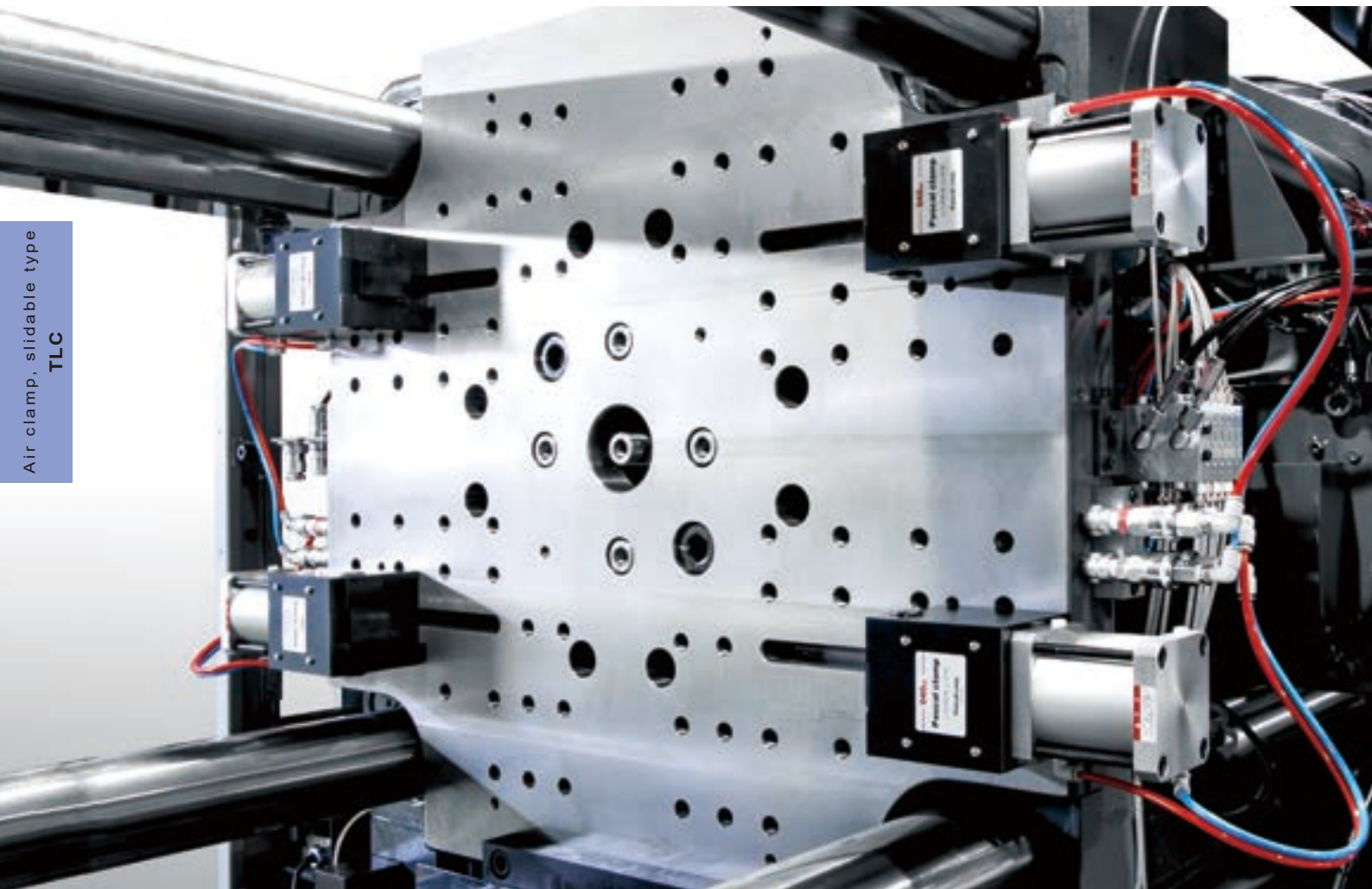

2,200kN (220ton) IMM vertical loading Air clamp, slidable type TLC



model TLC

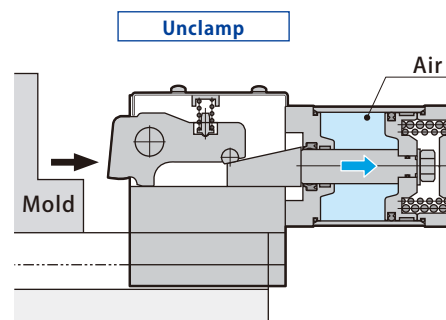
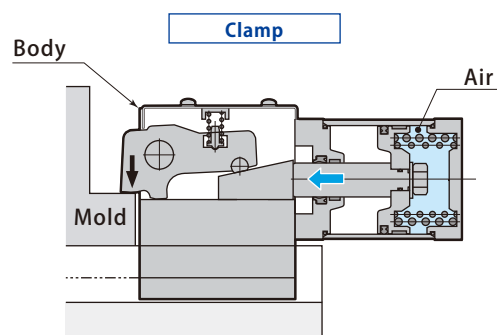

It is mounted on the T-slot and slidable by hand. The clamp lever is **not retracted** back in the body at time of unclamping.

TLC & Die setter

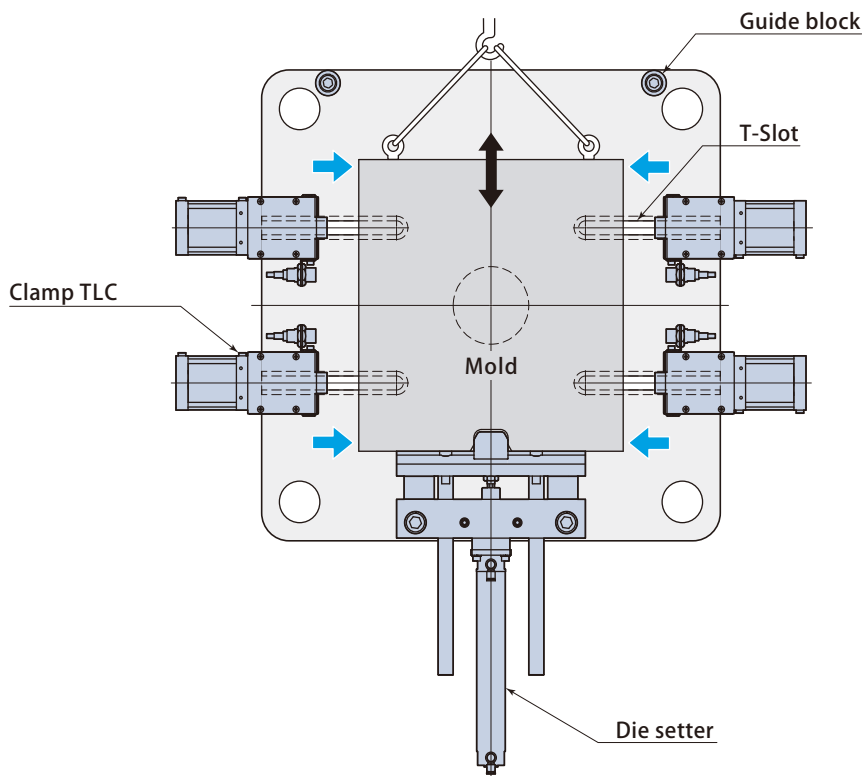

■ Model designation

■ Option

TLC 100 —

- 1 Holding force
- 4 Mold plate thickness h dimension (mm) **page → 54**

- E0 ~ E3 With mold detection proximity switch
- G With handle
- S Low distance clamp type
- V Heat proof type

1 Specifications

Model		TLC010	TLC016	TLC025	TLC040	TLC063	TLC100	TLC160	
Holding force	At air pressure 0.49 MPa	kN	9.8	15.6	24.5	39.2	61.7	98	157
	At air pressure 0.39 MPa	kN	9.8	15.6	24.5	39.2	61.7	98	157
	At no air pressure (0MPa)	kN	3.92	6.17	9.8	15.6	24.5	39.2	61.7
Clamping force	At air pressure 0.49 MPa	kN	3.92	6.17	9.8	15.6	24.5	39.2	61.7
Residual clamping force	At no air pressure (0MPa)	kN	2.94	4.9	7.84	11.7	19.6	31.3	49
Full stroke		mm	3	3	3	3.8	3.8	4.2	5
Clamping stroke		mm	1	1	1	1.2	1.2	1.2	1.2
Safety stroke		mm	2	2	2	2.6	2.6	3.0	3.8
Operating air pressure		MPa	0.39 ~ 0.49						
Proof pressure		MPa	0.68						
Operating temperature		°C	0 ~ 70 (5 ~ 120 by heat proof type *)						
Weight		kg	2.4	3.3	4.4	8.2	13.6	25.9	55

- Weight varies according to the dimension of clamp T-leg and mold plate thickness h.
- Refer to **page → 67** for the details of cutout dimensions on mold.
- Residual clamping force : the clamping force when air pressure drops to zero after clamp is clamped the mold at air pressure 0.49MPa.
- * Proximity switch and auto switch will not become a heat proof type.

Dimensions

Unclamp

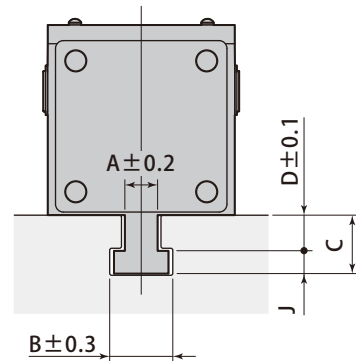
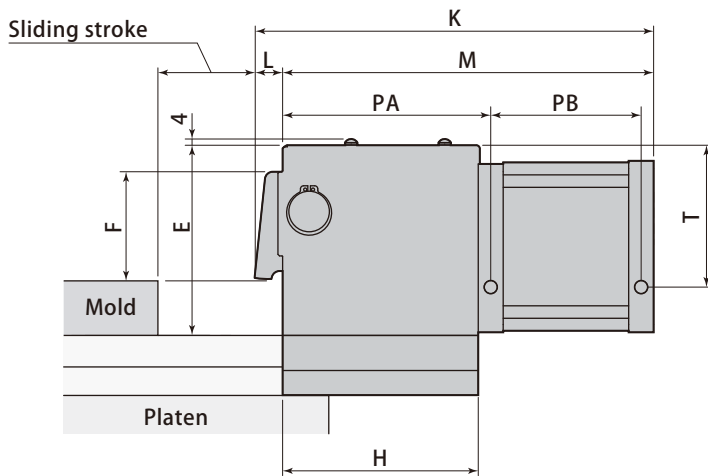
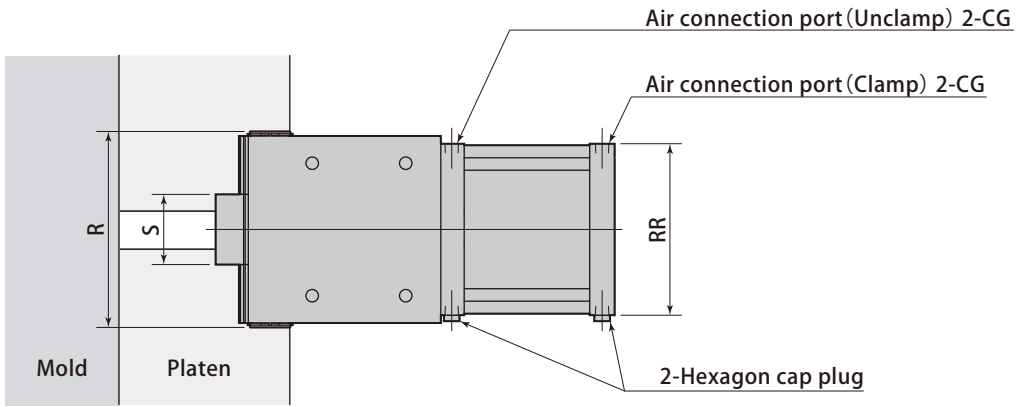

Clamp

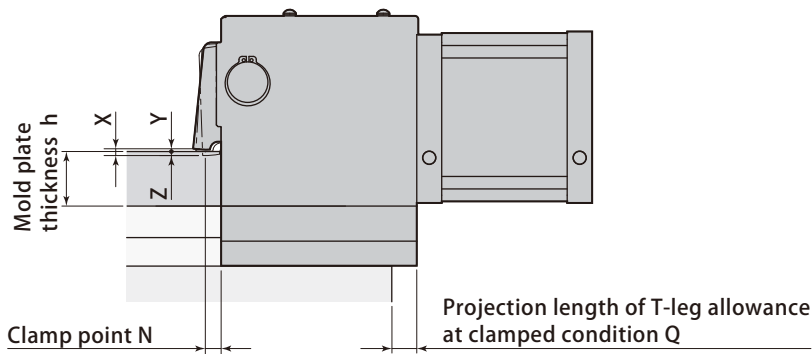

T-slot dimension and mold plate thickness

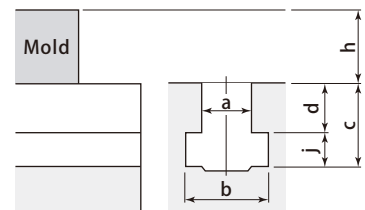

- Specify T-slot dimensions (a, b, c, d, j) and mold plate thickness (h).
- For "d" dimension of T-slot
For retrofit : Specify to 0.1 mm
For new machine : Machining tolerance shall be ±0.2 mm
- Dimensions (A, B, C, D, J) shall be determined according to T-slot dimensions.

								mm
Model	TLC010	TLC016	TLC025	TLC040	TLC063	TLC100	TLC160	
Air connection port CG	Rc1/8	Rc1/8	Rc1/8	Rc1/8	Rc1/8	Rc1/8	Rc1/4	
Min. E	64	69	79	102	122	147	182	
Standard F	28	30.5	36	55.5	70	87	115	
H	78	81	91	110.5	125.5	150	181	
K	178	186	200	233	256	302	368	
L	12	12	13	16	18	22	27	
M	166	174	187	217	238	280	341	
N	7	7	7.5	9	10	11.5	14	
PA	86	89	99	118.5	133.5	159	192	
PB	72	77	80	90.5	96.5	113	138	
Projection length of T-leg allowance at clamped condition Q	13	13	18	27.5	33.5	38	50	
R	59.3	73.3	85.3	105.7	125.7	152.3	178.8	
RR	50	60	70	90	110	136	171	
S	16	22	27	35	45	55	65	
T	46	49	58	71	91	103	135	
Full stroke X	3	3	3	3.8	3.8	4.2	5	
Clamping stroke Y	1	1	1	1.2	1.2	1.2	1.2	
Safety stroke Z	2	2	2	2.6	2.6	3	3.8	
Min. a	10	12	14	16	20	23	28	
Min. A	9	11	13	15	18.5	21.5	26.5	
Min. j	8	9	11	13	15	17	20	
4 Min. h	20	25	30	30	35	40	40	

- When newly machining T-slot, it is recommended to apply the dimensions specified on **page → 67**.
- The tolerance of mold plate thickness h shall be $\pm 0.3\text{mm}$.
- Hex socket cap plug to be provided for air connection ports. (2 pcs)
- A flow control valve is not necessary in the air circuit.

Automatic slidable clamp with air cylinder. It enables to shorten the mold change time.

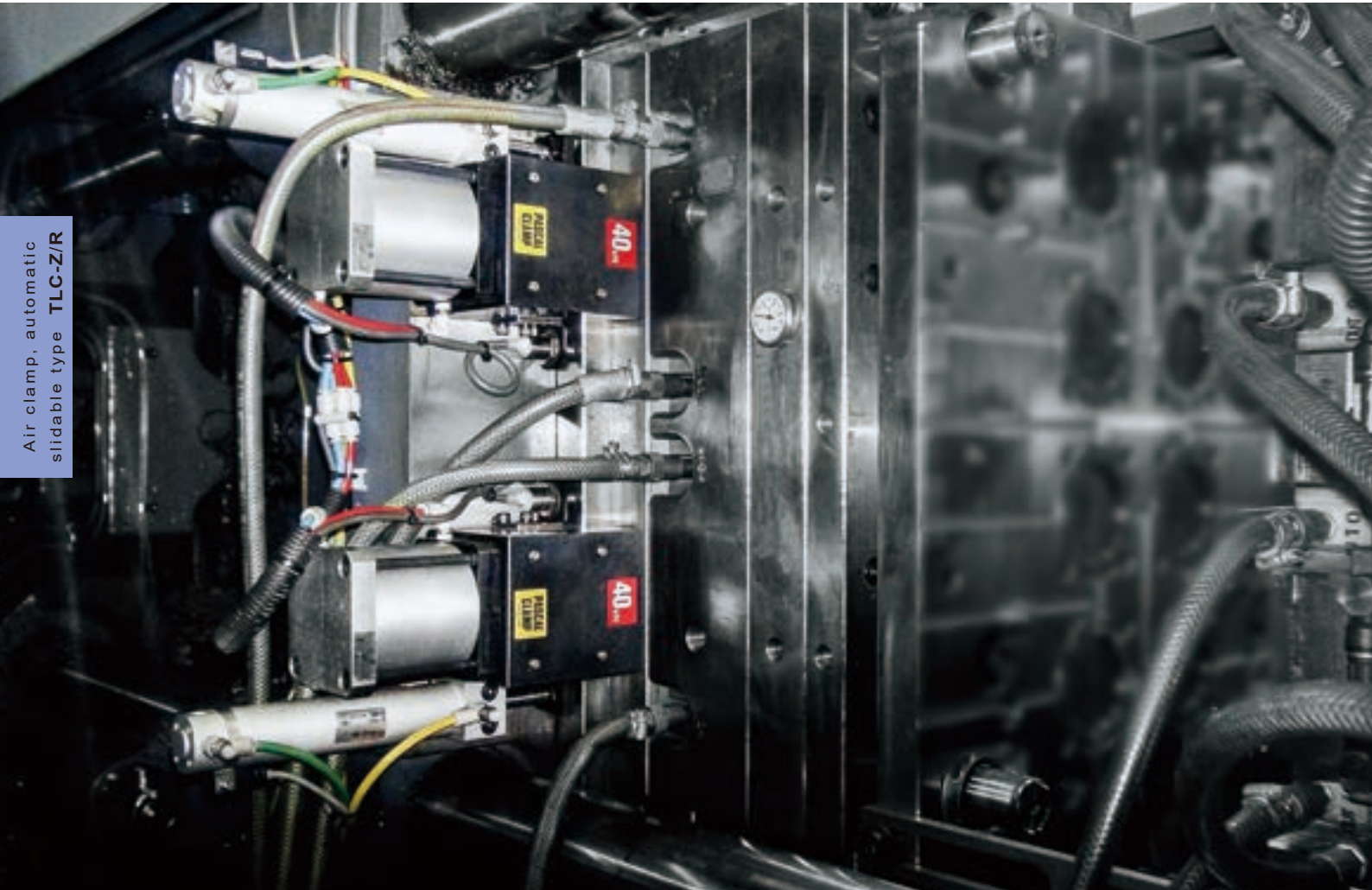

Air clamp, automatic slidable type TLC-Z/R

1,100kN(110ton) IMM vertical loading Air clamp, automatic slidable type TLC-Z

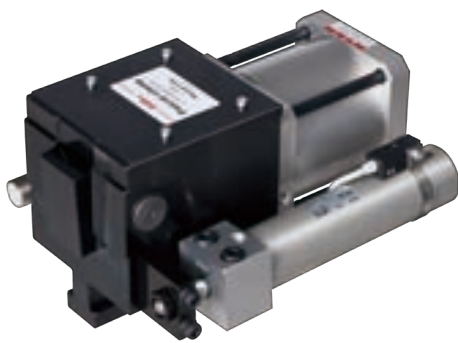

model **TLC-Z/R**

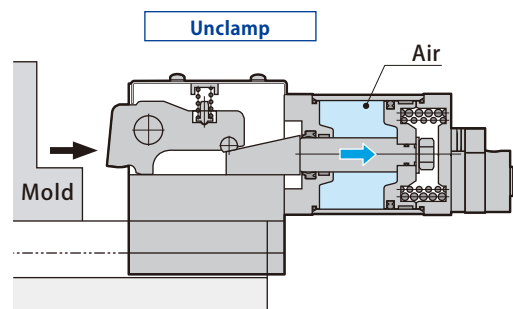
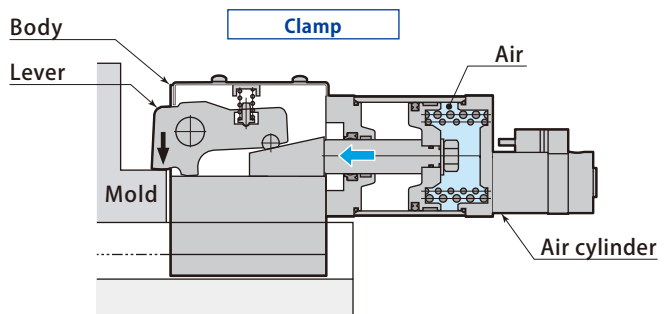

It slides automatically with air cylinder.
The clamp lever is **not retracted** back in the body at time of unclamping.

TLC-Z & Die setter

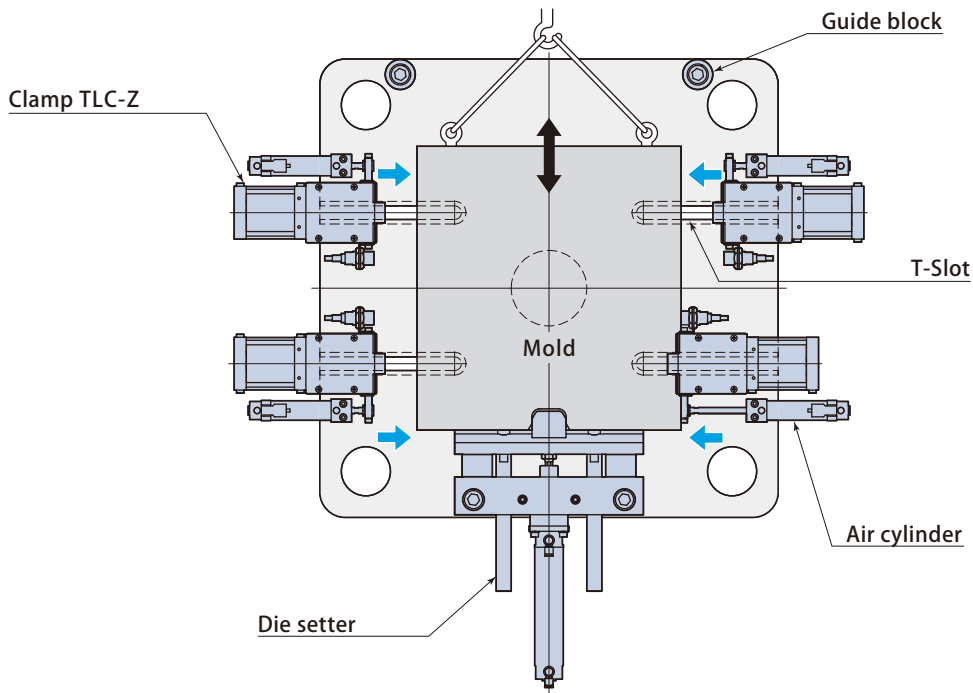

Air clamp, automatic slidable type TLC-Z/R

Model designation **TLC 025R 0 L - 075**

- 1 Holding force
- 6 Slide direction
Z : Horizontal R : Vertical
- 2 Proximity switch symbol
 page → 58
- 3 Air cylinder position
- 4 Mold plate thickness h dimension (mm)
 page → 58
- 5 Sliding stroke (mm) * Indicated in 3 digits

3 Air cylinder position

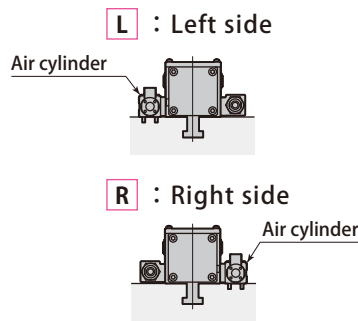

Option

- S Low distance clamp type
- V Heat proof type

1 5 Specifications

Model		TLC010Z	TLC016Z	TLC025Z	TLC040Z	TLC063Z	TLC100Z	TLC160Z	
		TLC010R	TLC016R	TLC025R	TLC040R	TLC063R	TLC100R	TLC160R	
Holding force	At air pressure 0.49 MPa	kN	9.8	15.6	24.5	39.2	61.7	98	157
	At air pressure 0.39 MPa	kN	9.8	15.6	24.5	39.2	61.7	98	157
	At no air pressure (0MPa)	kN	3.92	6.17	9.8	15.6	24.5	39.2	61.7
Clamping force	At air pressure 0.49 MPa	kN	3.92	6.17	9.8	15.6	24.5	39.2	61.7
Residual clamping force	At no air pressure (0MPa)	kN	2.94	4.9	7.84	11.7	19.6	31.3	49
Full stroke		mm	3	3	3	3.8	3.8	4.2	5
Clamping stroke		mm	1	1	1	1.2	1.2	1.2	1.2
Safety stroke		mm	2	2	2	2.6	2.6	3	3.8
Standard sliding stroke *1		mm	50, 75, 100, 125, 150			50, 75, 100, 125, 150, 200		50, 75, 100, 125, 150, 200, 250, 300	
Slide velocity		mm/s	30 ~ 80 (Adjusted by a flow control valve)						
Cylinder capacity	Clamp	cm ³	43	70	115	219	350	607	1116
	Unclamp	cm ³	39	63	104	197	318	560	1046
Operating air pressure		MPa	0.39 ~ 0.49						
Proof pressure		MPa	0.68						
Operating temperature		°C	0 ~ 70 (5 ~ 120 by heat proof type *2)						
Weight		kg	2.6	3.5	5.5	12.0	18.0	28	58

● Weight varies according to the sliding stroke and dimension of clamp T-leg. ● Residual clamping force : the clamping force when air pressure drops to zero after clamp is clamped the mold at air pressure 0.49MPa.
 ● Refer to page → 67 for the details of cutout dimensions on mold. *1 Contact Pascal for the sliding stroke which is not mentioned above. *2 Proximity switch and auto switch will not become a heat proof type.

Dimensions

The drawings indicate : air cylinder position **L** (Left).

Air clamp, automatic slidable type TLC-Z/R

Unclamp

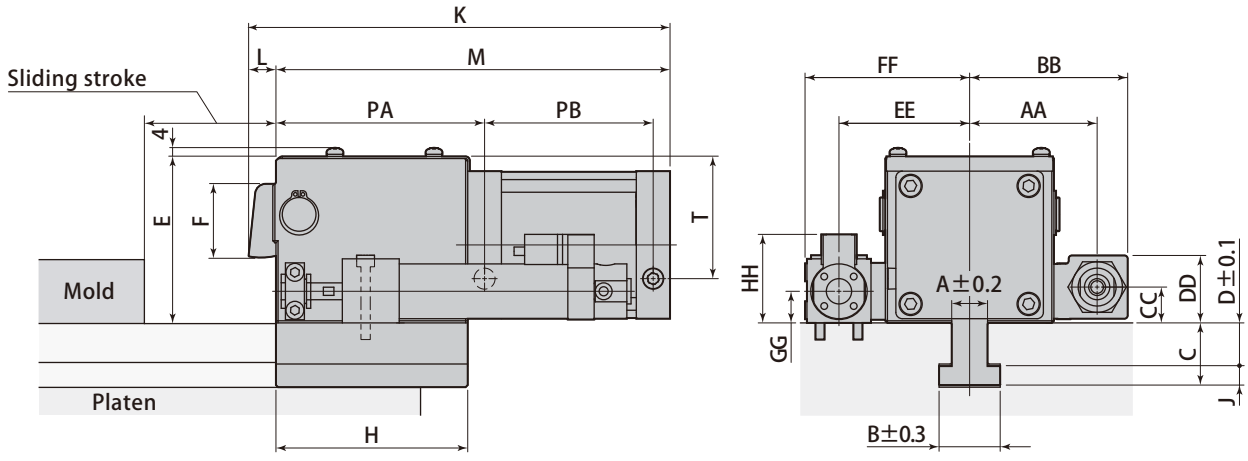
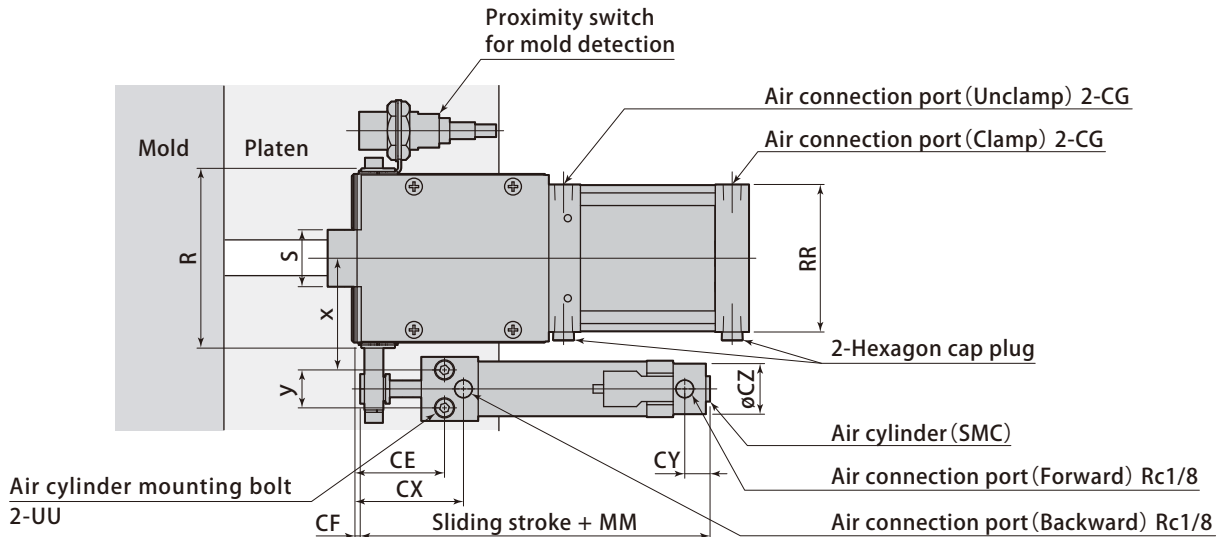

Clamp

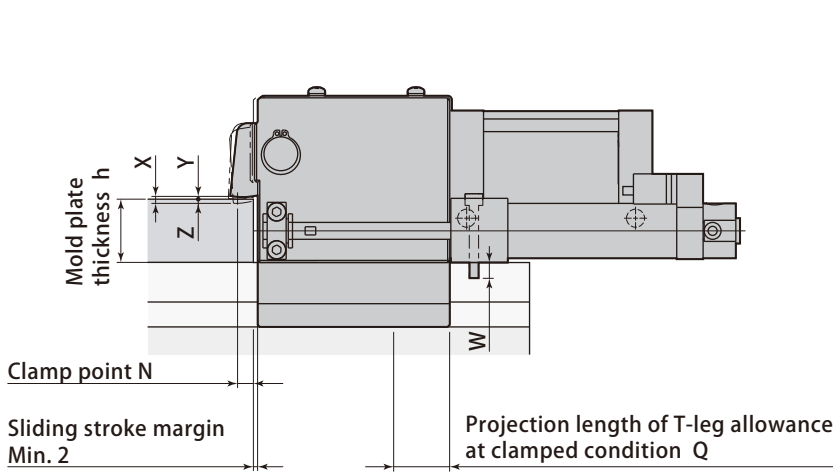

T-slot dimension and mold plate thickness

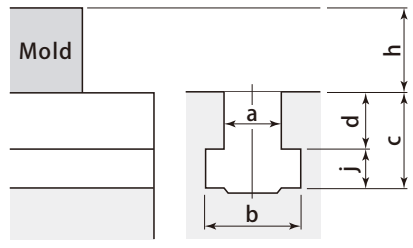

- Specify T-slot dimensions (a, b, c, d, j) and mold plate thickness (h).
- For "d" dimension of T-slot
For retrofit : Specify to 0.1 mm
For new machine : Machining tolerance shall be ± 0.2 mm
- Dimensions (A, B, C, D, J) shall be determined according to T-slot dimensions.

mm

Model	TLC010Z	TLC016Z	TLC025Z	TLC040Z	TLC063Z	TLC100Z	TLC160Z
	TLC010R	TLC016R	TLC025R	TLC040R	TLC063R	TLC100R	TLC160R
AA	47.5	54.5	60.5	70.5	80.5	98	110.5
BB	62	69	75	85	95	113	125.5
CC	17	17	17	21	21	32	32
CE	42.5	42.5	42.5	47	47	71	73
CF	2.5	2.5	2.5	2	2	9	9
Air connection port CG	Rc1/8	Rc1/8	Rc1/8	Rc1/8	Rc1/8	Rc1/8	Rc1/4
CX	51.5	51.5	51.5	60	60	87	93
CY	12	12	12	12	12	14	14
CZ	26	26	26	38	38	58	72
DD	32	32	32	38.5	38.5	63	69
Min. E	64	69	79	102	122	147	182
EE	49	56	62	76	86	115.5	134
F	28	30.5	36	55.5	70	87	115
FF	65.1	72.1	78.6	97.2	107.2	152.5	172.3
GG	15	15	15	21	21	32	38
H	78	81	91	110.5	125.5	150	181
HH	42	42	42	54	54	74	87
K	178	186	200	233	256	302	368
L	12	12	13	16	18	22	27
M	166	174	187	217	238	280	341
Standard sliding stroke	50, 75, 100, 125, 150			50, 75, 100, 125, 150, 200		50, 75, 100, 125, 150, 200, 250, 300	
MM	108.5	108.5	108.5	119	119	164	170
N	7	7	7.5	9	10	11.5	14
PA	86	89	99	118.5	133.5	159	192
PB	72	77	80	90.5	96.5	112	138
Projection length of T-leg allowance at clamped condition Q	13	13	18	27.5	33.5	38	50
R	59.3	73.3	85.3	105.7	125.7	152.3	178.8
RR	50	60	70	90	110	136	171
S	16	22	27	35	45	55	65
T	46	49	58	71	91	103	135
UU	M5	M5	M5	M8	M8	M12	M16
W	9.5	9.5	9.5	9.6	9.6	17	17.9
x	40	47	53	64	74	95	111
y	18	18	18	24	24	41	46
Full stroke X	3	3	3	3.8	3.8	4.2	5
Clamping stroke Y	1	1	1	1.2	1.2	1.2	1.2
Safety stroke Z	2	2	2	2.6	2.6	3	3.8
Min. a	10	12	14	16	20	23	28
Min. A	9	11	13	15	18.5	21.5	26.5
Min. j	8	9	11	13	15	17	20
4 Min. h	20	25	30	30	35	40	40

Air clamp, automatic slidable type TLC-Z/R

- In case of newly machining T-slot, refer to **page → 67**.
- Height of lever F varies according to the dimension of h.
- In case of smaller than the minimum h dimension, it is **Clamp lever low distance type**.
- The tolerance of mold plate thickness h shall be ±0.3mm.
- Hex socket cap plug to be provided for air connectoin ports. (2 pcs)
- A flow control valve is not necessary in the air circuit.
- Contact Pascal for the sliding stroke which is not mentioned above.

2 Proximity switch (OMRON)

Proximity switch symbol	0	1	2	3
Switch model	2-Wire DC E2E-X7D1-N	3-Wire DC E2E-X5E1	2-Wire AC E2E-X5Y1	3-Wire DC E2E-X5F1
Supply voltage V	DC10 ~ 30	DC10 ~ 40	AC20 ~ 264	DC10 ~ 40
Leakage current mA	0.8 and under	No	1.7 and under	No
Current consumption mA	No	13 and under	No	13 and under
Control output (Switching capacity) mA	3 ~ 100	200	5 ~ 300	200

- Operating temperature : 0 ~ 70°C
- Insulation vinyl cable length : 5m (Oil proof type, 0.5mm²)
- When using Pascal control box, 3-wire DC type (1) shall be delivered.

Auto switch (SMC)

Switch model	D-B54L		
Load voltage V	DC24	AC100	AC200
Range of load current mA	5 ~ 50	5 ~ 25	5 ~ 12.5

- Operating temperature : 0 ~ 70°C
- Insulation vinyl cable length : 3m (Oil proof type, 0.3mm²)

It enables the clamp to slide it manually even if machine platens do not have T-slots.

Air clamp, T-slot-less
slidable type **TLA-M**



400kN (40ton) Vertical IMM Air clamp, T-slot-less slidable type TLA-M



model **TLA-M**

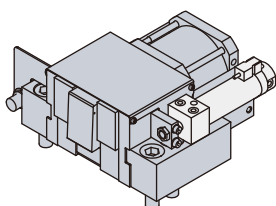

There is also an automatic slidable model with an air cylinder.
Please contact Pascal for the details.

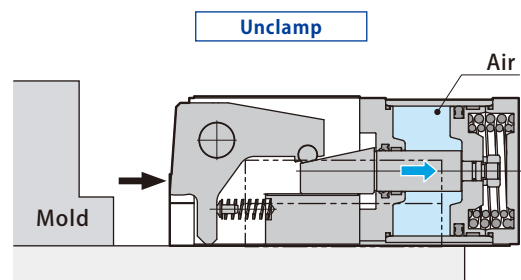
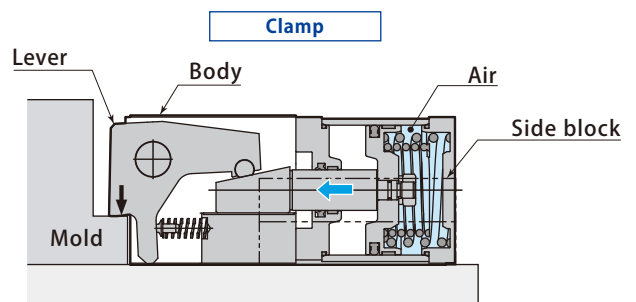

The clamp lever is **not retracted** back in the body at time of unclamping.
Forward and backward of the clamp itself is manual.

TLA-M & Die setter

IMM vertical loading

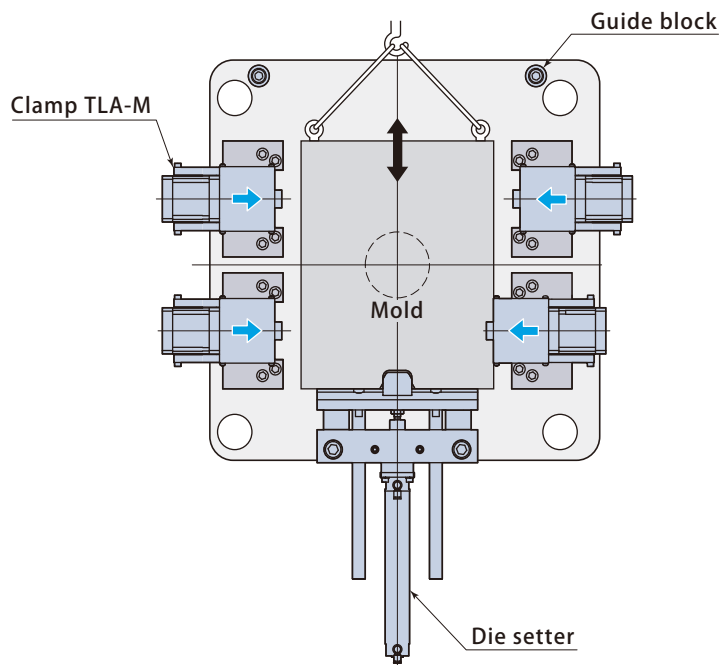

TLA-M

Vertical IMM

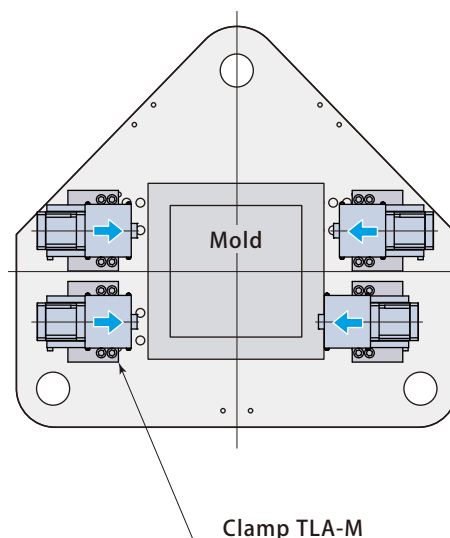

Air clamp, T-slot-less slidable type **TLA-M**

■ Model designation

■ Option

TLA 025 M — □

- 1 Holding force
- 4 Mold plate thickness h dimension (mm) **page → 62**

E0 ~ E3 With mold detection proximity switch

S Low distance clamp type

V Heat proof type

1 Specifications

Model		TLA010M	TLA016M	TLA025M	TLA040M	TLA063M
Holding force	At air pressure 0.49 MPa	kN 9.8	15.6	24.5	39.2	61.7
	At air pressure 0.39 MPa	kN 9.8	15.6	24.5	39.2	61.7
	At no air pressure (0MPa)	kN 3.92	6.17	9.8	15.6	24.5
Clamping force	At air pressure 0.49 MPa	kN 3.92	6.17	9.8	15.6	24.5
Residual clamping force	At no air pressure (0MPa)	kN 2.94	4.9	7.84	11.7	19.6
Full stroke		mm 2.7	2.7	2.8	3.2	3.2
Clamping stroke		mm 1	1	1	1.2	1.2
Safety stroke		mm 1.7	1.7	1.8	2.0	2.0
Standard sliding stroke		mm 35	40	50	60	75
Cylinder capacity	Clamp	cm ³ 27	46	79	148	234
	Unclamp	cm ³ 34	52	85	160	258
Operating air pressure	MPa	0.39 ~ 0.49				
Proof pressure	MPa	0.68				
Operating temperature	°C	0 ~ 70 (5 ~ 120 by heat proof type)				
Weight	kg	3.1	4.8	7.4	14.3	25.4

● Residual clamping force : the clamping force when air pressure drops to zero after clamp is clamped the mold at air pressure 0.49MPa.

● Refer to **page → 67** for the details of cutout dimensions on mold.

Dimensions

Unclamp

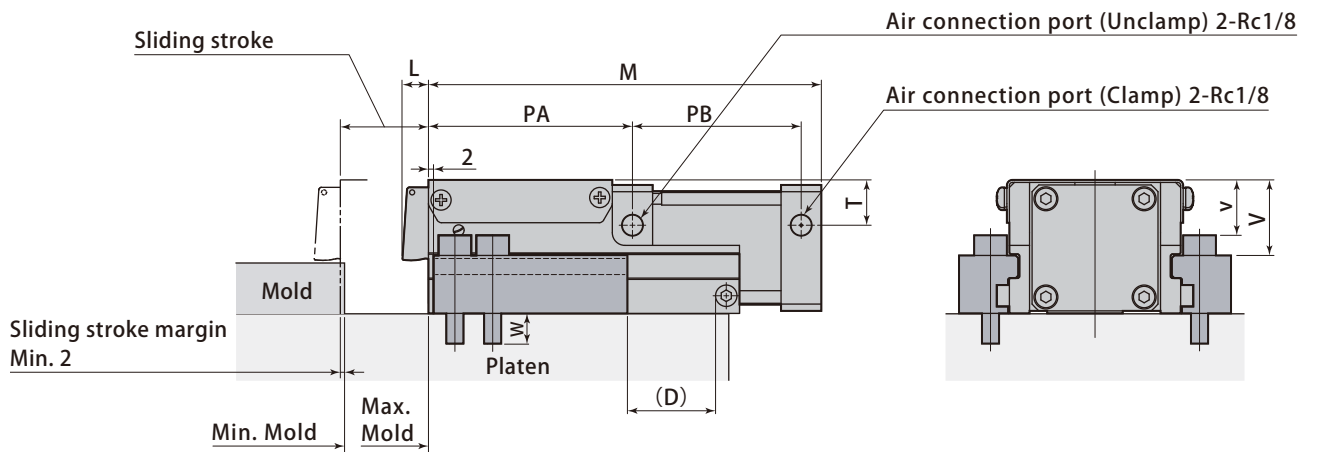
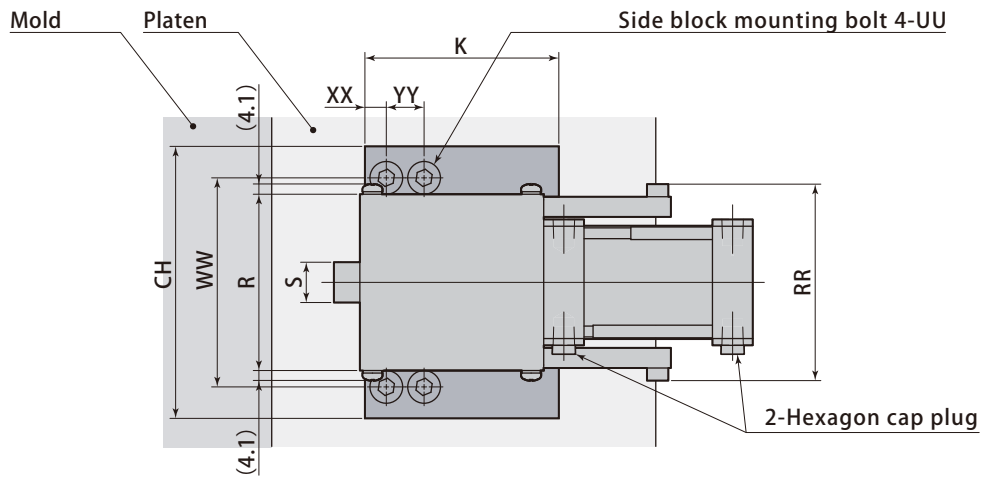

Clamp

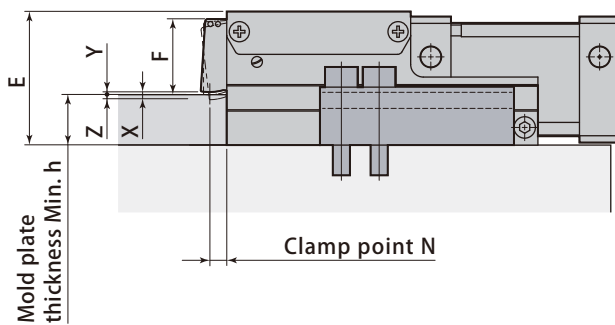

mm					
Model	TLA010M	TLA016M	TLA025M	TLA040M	TLA063M
CH	100	128	150	172	237
Min. E	53	62	72	92	112
F	30	33	38	58	73
K	77	85	94	118	136
L	10	11	11	15	16
M	156	161	175	200	227.5
N	7	7	7.5	10	10.7
PA	81	83	94	110	124.5
PB	67	70	73	82	87.5
R	70	82	98	124	154
RR	78	90	108	138	168
S	16	22	27	35	45
T	18	19	20	30	30
UU	M8	M10	M12	M14	M20
V	30	35.5	38.5	48	54
v	22	25.5	26.5	34	34
W	12	13.5	16.5	21	27
WW	83	98	116	145	190
XX	8.5	10	12	13	18
YY	15	18	20	26	36
Full stroke X	2.7	2.7	2.8	3.2	3.2
Clamping stroke Y	1	1	1	1.2	1.2
Safety stroke Z	1.7	1.7	1.8	2	2
4 Min. h	20	25	30	30	35

- Hex socket cap plug to be provided for air connection ports. (2 pcs)
- A flow control valve is not necessary in the air circuit.
- WW, XX, YY varies according to the installed position of clamp.
- The dimensions varies in case the clamp with **mold detection prox.switch** and **automatic slidable type**. Please contact Pascal later.

It is the clamp with safety and high reliability, which does not lose holding force because of the strong spring and special wedge mechanism even at time of zero air pressure.

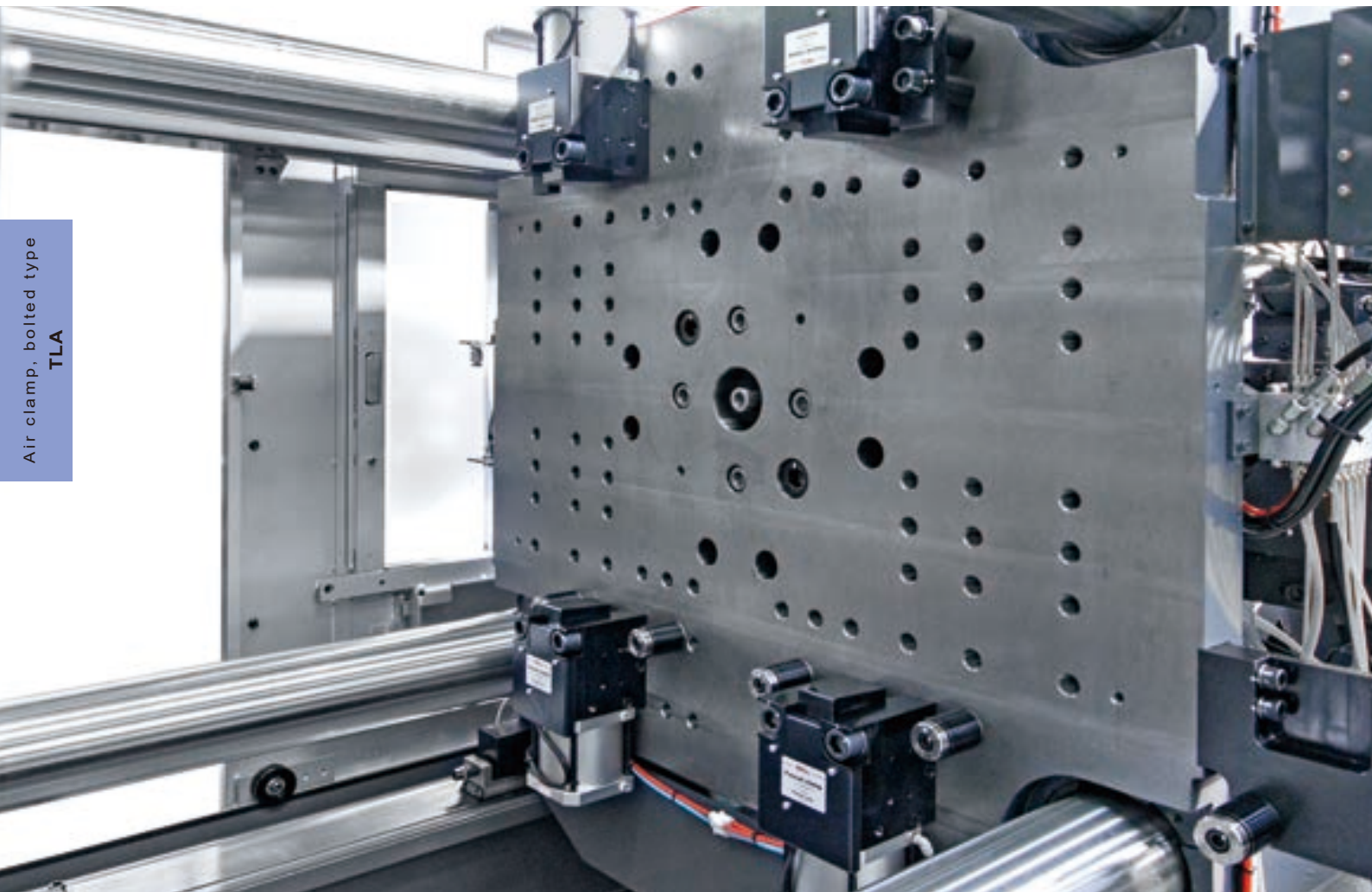

3,500kN (350ton) IMM horizontal loading Air clamp, bolted type TLA



model **TLA**

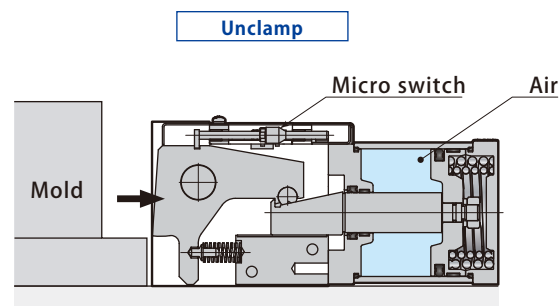
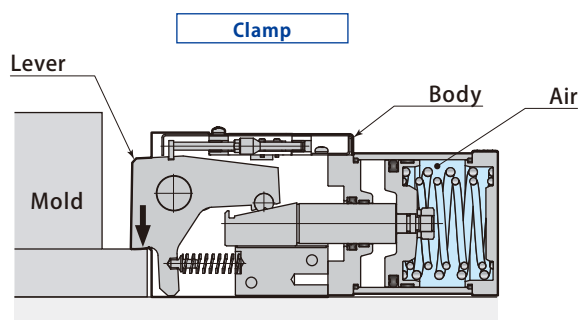

At time of unclamping, the lever is retracted back in the body and it does not interfere in loading/unloading the mold.

TLA & Positioning block

IMM vertical loading

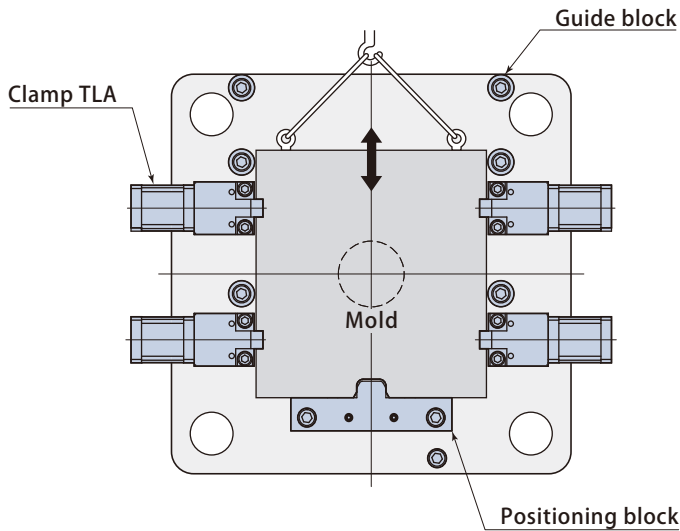

TLA

Vertical IMM

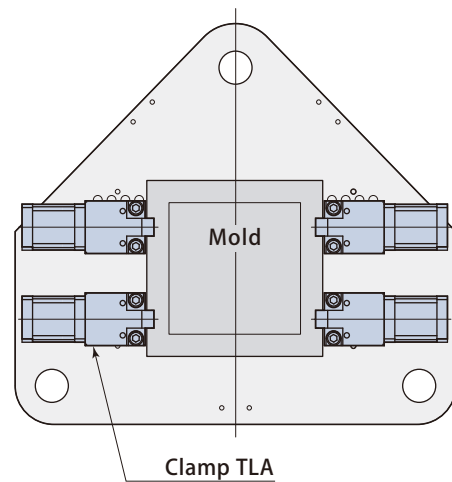

Air clamp, bolted type
TLA

■ Model designation

TLA 040 — □

- 1 Holding force
- 4 Mold plate thickness h dimension (mm) **page → 66**

■ Option

- S** Low distance clamp type
- V** Heat proof type

1 Specifications

Model		TLA010	TLA016	TLA025	TLA040	TLA063	TLA100	TLA160	TLA250	
Holding force	At air pressure 0.49 MPa	kN	9.8	15.6	24.5	39.2	61.7	98	156	245
	At air pressure 0.39 MPa	kN	9.8	15.6	24.5	39.2	61.7	98	156	245
	At no air pressure (0MPa)	kN	3.92	6.17	9.8	15.6	24.5	39.2	61.7	98
Clamping force	At air pressure 0.49 MPa	kN	3.92	6.17	9.8	15.6	24.5	39.2	61.7	98
Residual clamping force	At no air pressure (0MPa)	kN	2.94	4.9	7.84	11.7	19.6	31.3	49.0	78.4
Full stroke		mm	2.2	2.2	2.2	2.6	2.6	2.8	3.0	3.4
Clamping stroke		mm	1	1	1	1.2	1.2	1.2	1.2	1.4
Safety stroke		mm	1.2	1.2	1.2	1.4	1.4	1.6	1.8	2
Cylinder capacity	Clamp	cm ³	43	70	115	219	350	607	1116	1993
	Unclamp	cm ³	39	63	104	197	318	560	1046	1869
Operating air pressure	MPa	0.39 ~ 0.49								
Proof pressure	MPa	0.68								
Operating temperature	°C	0 ~ 70 (5 ~ 120 by heat proof type)							0 ~ 70	
Weight	kg	2.3	3.2	4.2	7.8	13	25	43	85	

- Residual clamping force : the clamping force when air pressure drops to zero after clamp is clamped the mold at air pressure 0.49MPa.
- Refer to **page → 67** for the details of cutout dimensions on mold.

Dimensions

TLA 010 ~ 100-□

Mold plate thickness
h dimension (mm)

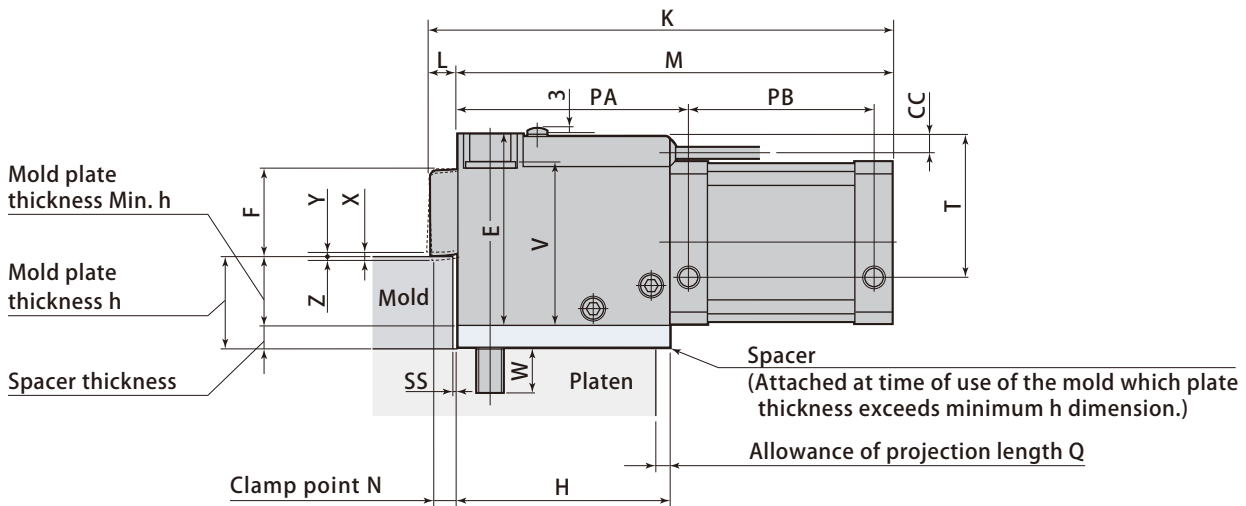
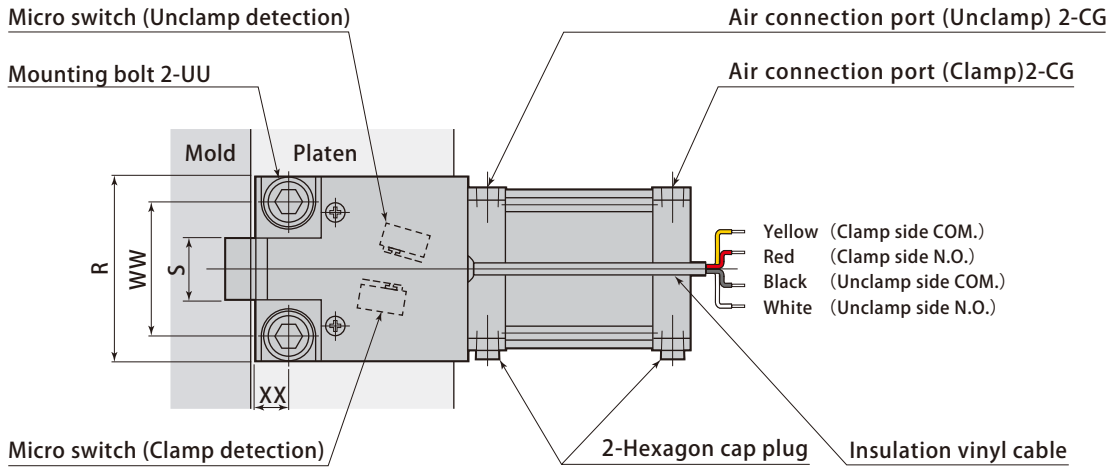

TLA 160 / 250-□

Mold plate thickness
h dimension (mm)

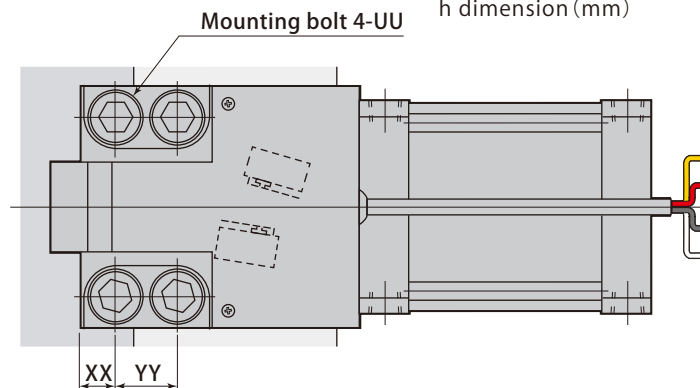

Air clamp, bolted type
TLA

	mm							
Model	TLA010	TLA016	TLA025	TLA040	TLA063	TLA100	TLA160	TLA250
Air connection port CG	Rc1/8	Rc1/8	Rc1/8	Rc1/8	Rc1/8	Rc1/8	Rc1/4	Rc1/4
CC	8	8	8	8	8	8	8	8.5
Min. E	65	73	83	103	123	148	184	224
F	30	32	38	57	72	93	102	129
H	78	81	91	110.5	125.5	150	181	221
K	176.3	186	200	232	254	298.4	361.7	435.2
L	10.3	12	13	15	16	18.4	21.7	25.2
M	166	174	187	217	238	280	340	410
N	7	8	9	10	11	12	14	16
PA	86	89	99	118.5	133.5	159	191	235
PB	72	77	80	90.5	96.5	113	138	160
Allowance of projection length Q	28	13	1	36.5	39.5	20	1	1
R	54	68	80	100	120	146	170	210
S	16	22	27	35	45	55	65	75
SS	2	2	3	3	3	3	3	3
T	48	54	62	73	93	105	137	167
UU	M8	M10	M12	M16	M20	M24	M24	M30
V	57	63	71	87	103	124	160	194
W	13 ~ 18	17 ~ 22	19 ~ 24	23 ~ 28	32 ~ 37	36 ~ 41	40 ~ 45	46 ~ 51
WW	33	50	58	72	86	105	128	158
XX	8	12	14	18	21	25	25	31
YY	-	-	-	-	-	-	45	55
Full stroke X	2.2	2.2	2.2	2.6	2.6	2.8	3	3.4
Clamping stroke Y	1	1	1	1.2	1.2	1.2	1.2	1.4
Safety stroke Z	1.2	1.2	1.2	1.4	1.4	1.6	1.8	2
4 Min. h	20	25	30	30	35	40	40	50

- The tolerance of mold plate thickness h shall be ± 0.3 mm.
- Use the mounting bolts from the following strength classification.
TLA010 ~ 063 : 12.9
TLA100 ~ 250 : 10.9
- Hex socket cap plug to be provided for air connection ports. (2 pcs)
- A flow control valve is not necessary in the air circuit.
- The dimension W varies according to dimension h and length of mounting bolt.

Micro switch specifications (AZBIL)

Micro switch model	SSM33A1	
Rated voltage	V	AC250 DC30
Rated energizing current (Resistive load)	A	2 2

- Insulation vinyl cable length : 3m (Oil proof type, 0.5mm²)

T-slot, Cutout details and Clamp area details

T-slot and Cutout details

- Process with the below dimension in case of machining T-slot newly.

Recommended T-slot dimension

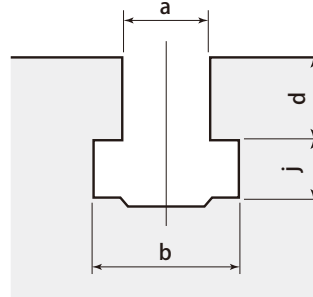

IMM	Mold clamping force	kN	~500	~1000	~1500	~2000	~3500	~5500	~6500	~8500	~13000	~30000	~35000
	Mold opening force	kN	40	80	100	160	250	400	640(400)	640	1000	1600	2000
T-slot dimension	a	mm	18 ^{+0.5} ₀		22 ^{+0.5} ₀		28 ^{+0.5} ₀		32 ^{+0.5} ₀				—
	b	mm	30 ⁺² ₀		37 ⁺³ ₀		46 ⁺⁴ ₀		53 ⁺⁴ ₀				—
	d	mm	18 ^{±0.2}		22 ^{±0.2}		28 ^{±0.2}		28 ^{±0.2}				—
	j	mm	12 ⁺² ₀		16 ⁺² ₀		20 ⁺² ₀		24 ⁺² ₀				—

- Mold plate should be machined referring to the dimensions shown below in case the mold is positioned by the block.

Cutout details

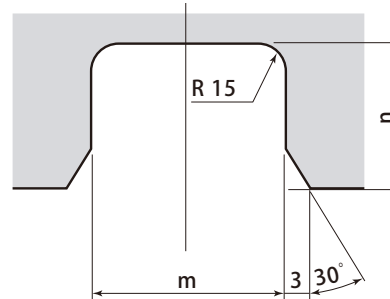

IMM	Mold clamping force	kN	~500	~1000	~1500	~2000	~3500	~5500	~6500	~8500	~13000	~30000	~35000
	Mold opening force	kN	40	80	100	160	250	400	640(400)	640	1000	1600	2000
Cutout details	m	mm		30 ^{+0.10} ₀		45 ^{+0.10} ₀	60 ^{+0.12} ₀	100 ^{+0.14} ₀				140 ^{+0.16} ₀	
	n	mm		30		30	35	40				45	

- To accommodate the clamp to the die as shown on the right, Pascal can provide a special designed clamp lever with the clamp. Contact Pascal for the details.

Clamp area details

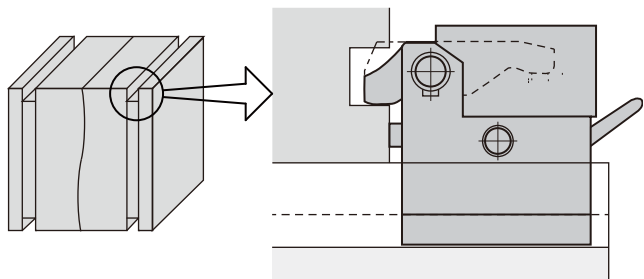

Unification of thickness of mold plate

The introduction of hydraulic and air clamp requires unification of thickness of mold plate.

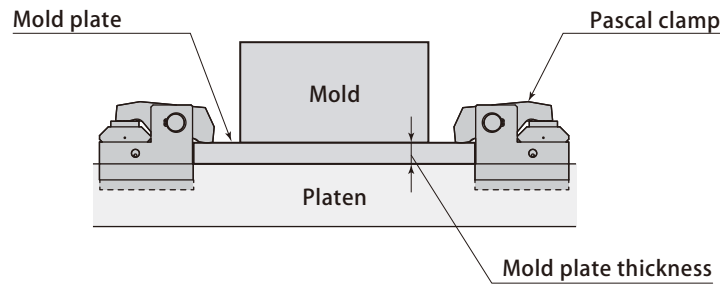

In case that the thickness of mold plate is not unified, standardize **the maximum thick dimension h** and add the **spacer** at the clamp point.

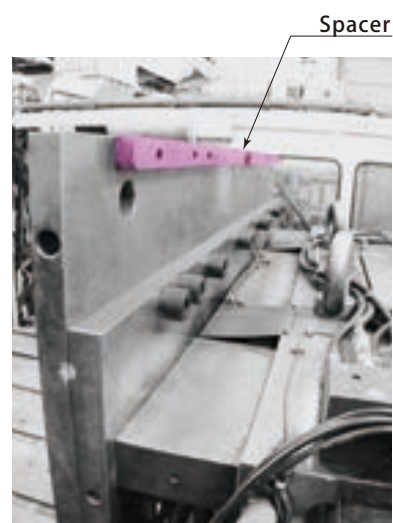
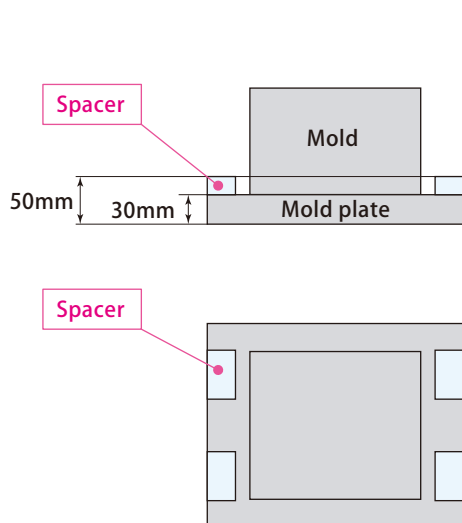
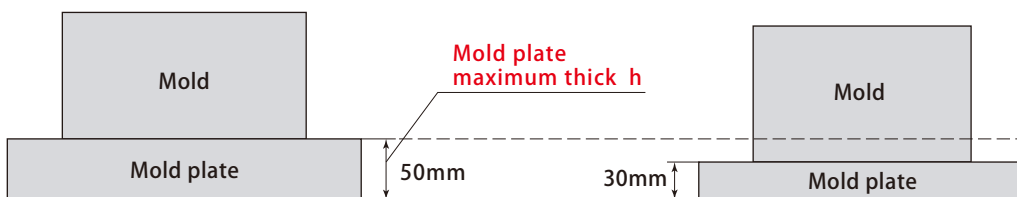

● Please contact for the details.

Addition of the hydraulic circuit

2 control circuits are recommended for clamp circuit on the movable platen.

The mold fall can be prevented with 2 control circuits, even if the pressure decreases in either one of 2 circuits.

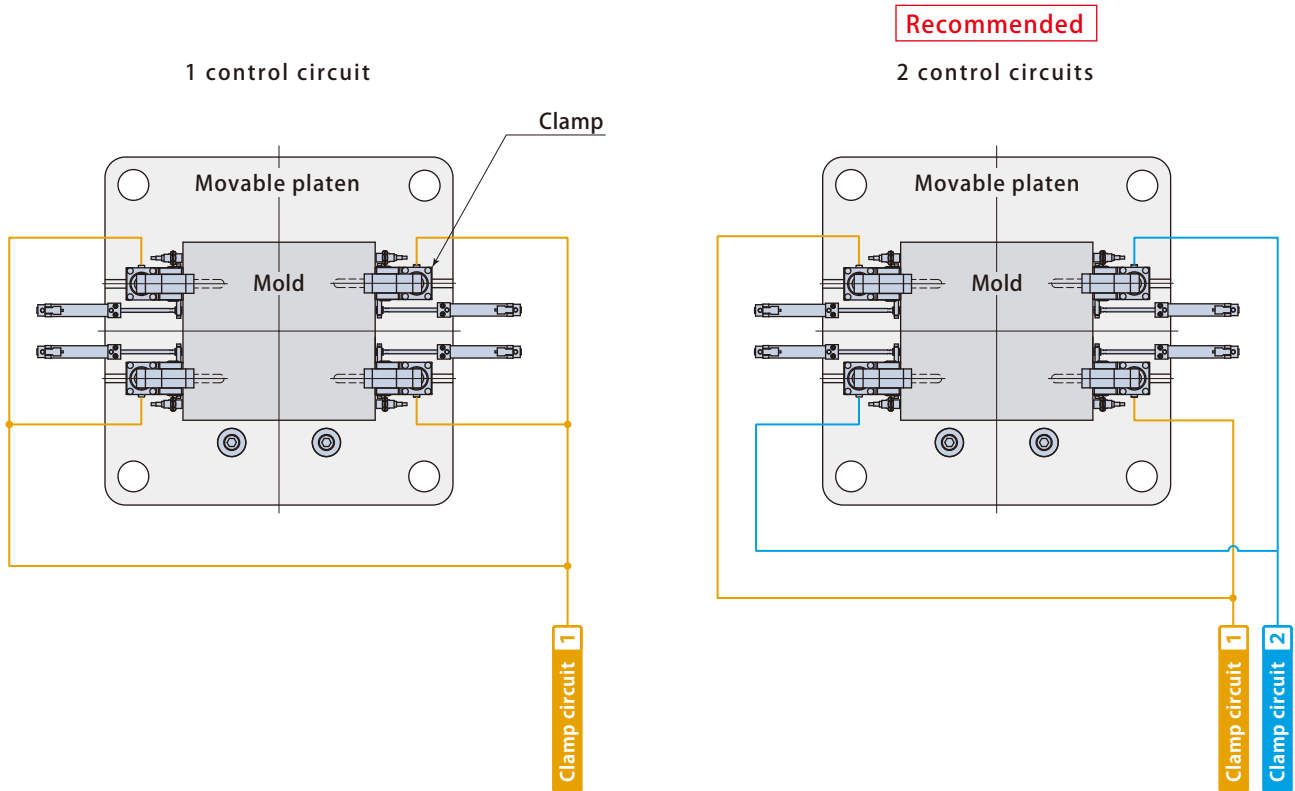

Use of the block for mold fall protection (Vertical loading)

Use of the block for mold fall protection is recommended on the movable side.

The mold fall to the underside can be prevented with the block, even if the pressure decreases and clamping force is loosened.

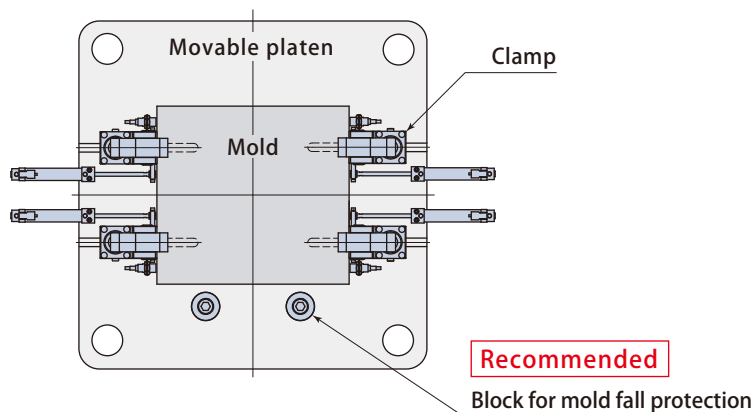

Pascal pump

model

X63



New series of Pascal pump model X63 which pursues more reliability.

Air-driven, Compact, High performance hydraulic pump

High cycle, reliable reciprocation of air and hydraulic piston ensures a repetitive suction and discharge oil process. As discharge pressure hikes up to the circuit set pressure, reciprocation goes slow eventually. Pascal pump stops at the time the discharge pressure reaches the set pressure then keeps balancing air and oil discharge pressure.

At the balanced condition, Pascal pump never consumes air and there is no power loss or oil temperature rise unlike an ordinary electric motor pump.

In the event of pressure drop (oil leakage) in the circuit, the pump immediately reacts to start pumping for recovering the pressure loss. When leaking oil, the pump restarts pumping and the sound of pumping is like an alarm for leakage to call operator for servicing.

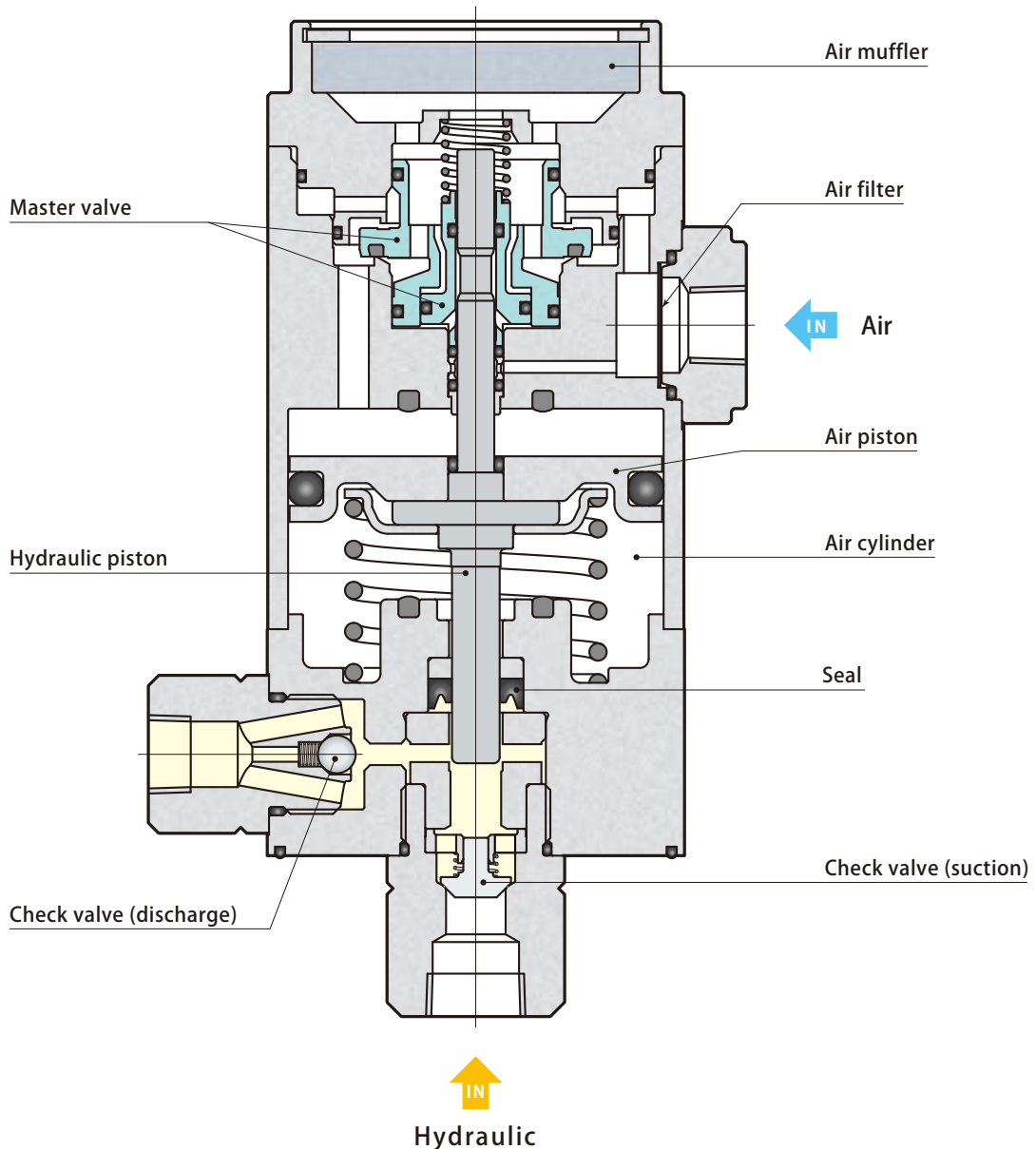

Pascal control unit

model

HCM

Control unit
HCM

Returning oil to the tank at air bleeding
Adopting transparent pipe to return the oil from air bleeding valve to the tank, air bleeding can be done without draining the oil.

Regulator fixed is mounted on the bracket which is impervious to vibration

Equipped with filter regulator as standard

1 Block-type Valve unit
Independent circuit valves have been configured as a block valve, improving maintainability.

Digital pressure switch
User-friendly display with 7 segments. It can also show abnormal pressure sign which allows hydraulic control unit to be compact.

Adoption of steel tank which is strong against impact and heat

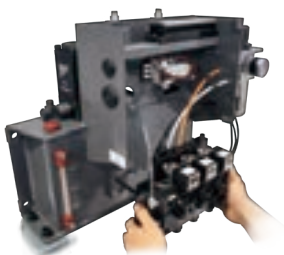

New control unit **HCM** with excellent maintenance

Air-driven hyd. control unit integrating electric control (solenoid operated), combined with Pascal pump and Pascal non-leak valve for medium and large-sized IMM.

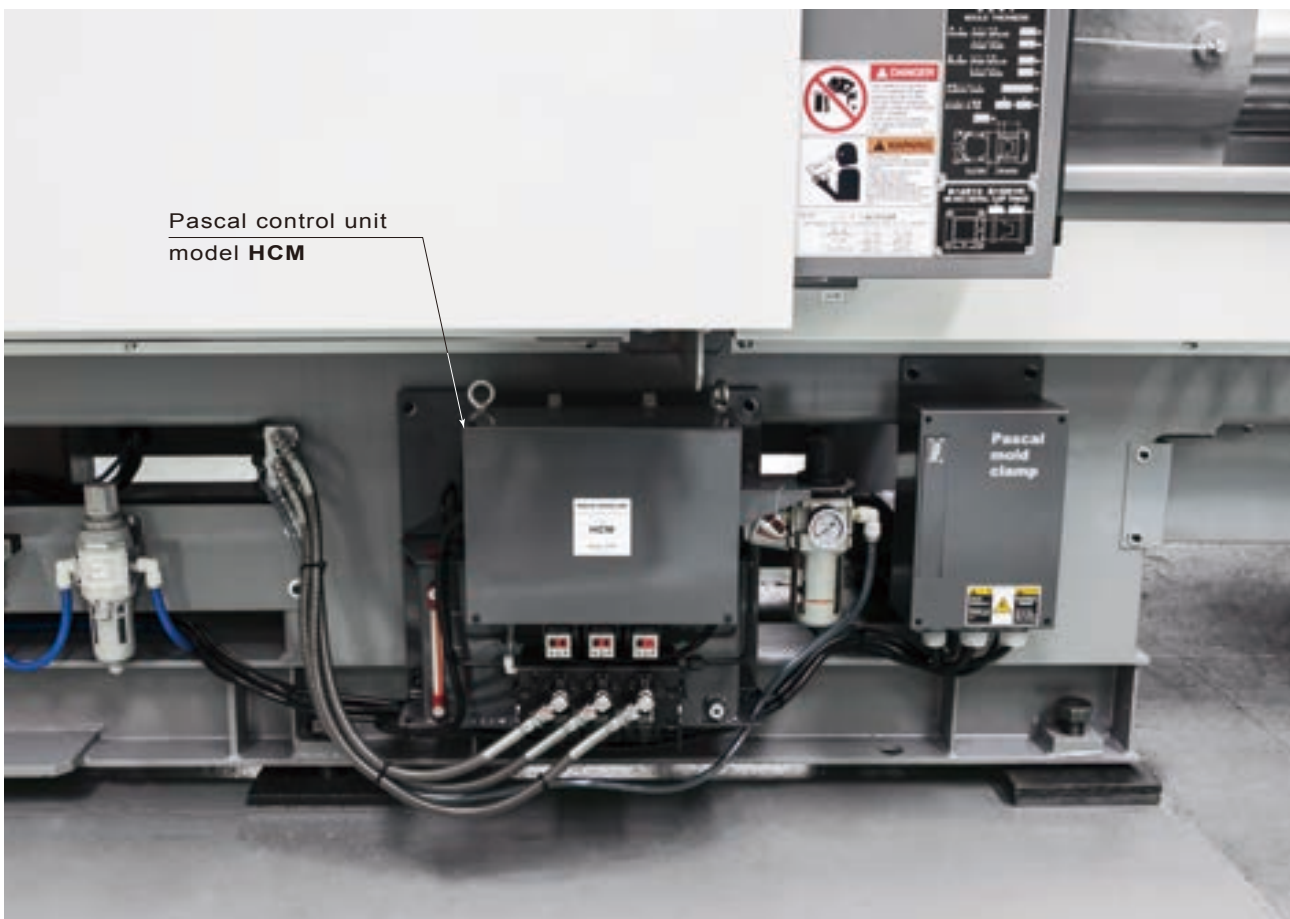



Model designation

HCS **A** - H2 **D D F** - **U**

- 1 Control voltage
- 2 Hydraulic circuits * Indicated in 1-4 alphabets
- 3 Oil pressure gauge for each circuit

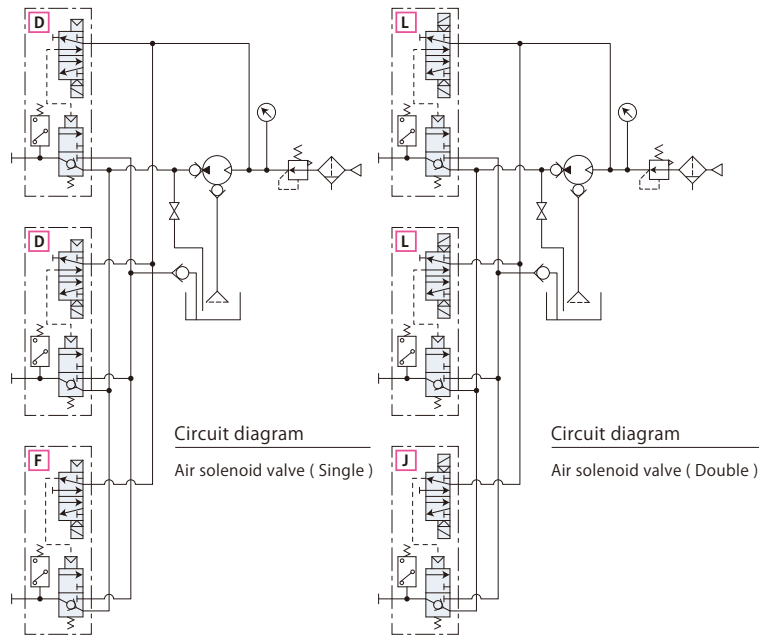

Control unit
HCS

1 Discharge pressure × Pump quantity **H2** : 24.5MPa × 1 unit **H3** : 15.6MPa × 1 unit

2 C port (with in-line filter)

: No : Yes
It corresponds only to HCS-D-H3.

3 Hydraulic circuit

S
Clamp circuit
Double solenoid valve + Relief valve for excessive high pressure

4 With hydraulic gauge for each circuit

: No
 : Yes

Specifications

Model		HCS-D-H2□-□	HCS-D-H3□-□
Pump quantity		1 unit	1 unit
Valve switching system		Pilot air	
Discharge pressure	MPa	24.5	15.6
Driving air pressure	MPa	0.47	0.47
Discharge volume (at no load)	L/min	1.3	2
Oil tank capacity	L	HIGH-LEVEL : 3.5	LOW-LEVEL : 1.5
Set pressure of pressure switch	MPa	14.7 (INC.)	8.8 (INC.)
Set pressure of relief valve	MPa	27.9	17.6
Air consumption rate	Nm ³ /min	Max. 0.4	Max. 0.4
Operating temperature	°C	0 ~ 50°C (No freezing)	
Applications (Example)	Clamp model × Quantity	TYA100 × 8 unit	TME025 × 8 unit
	HCS model	HCS-D-H2SSS	HCS-D-H3CSS

● Fluid used : General mineral based hydraulic oil (ISO-VG32 equivalent) ● It does not correspond to automatic slider/ air circuit for centering cylinder, and digital pressure gauge. If necessary, select model HCM page → 77.

● The drawings showing : HCS-D-H2SSS

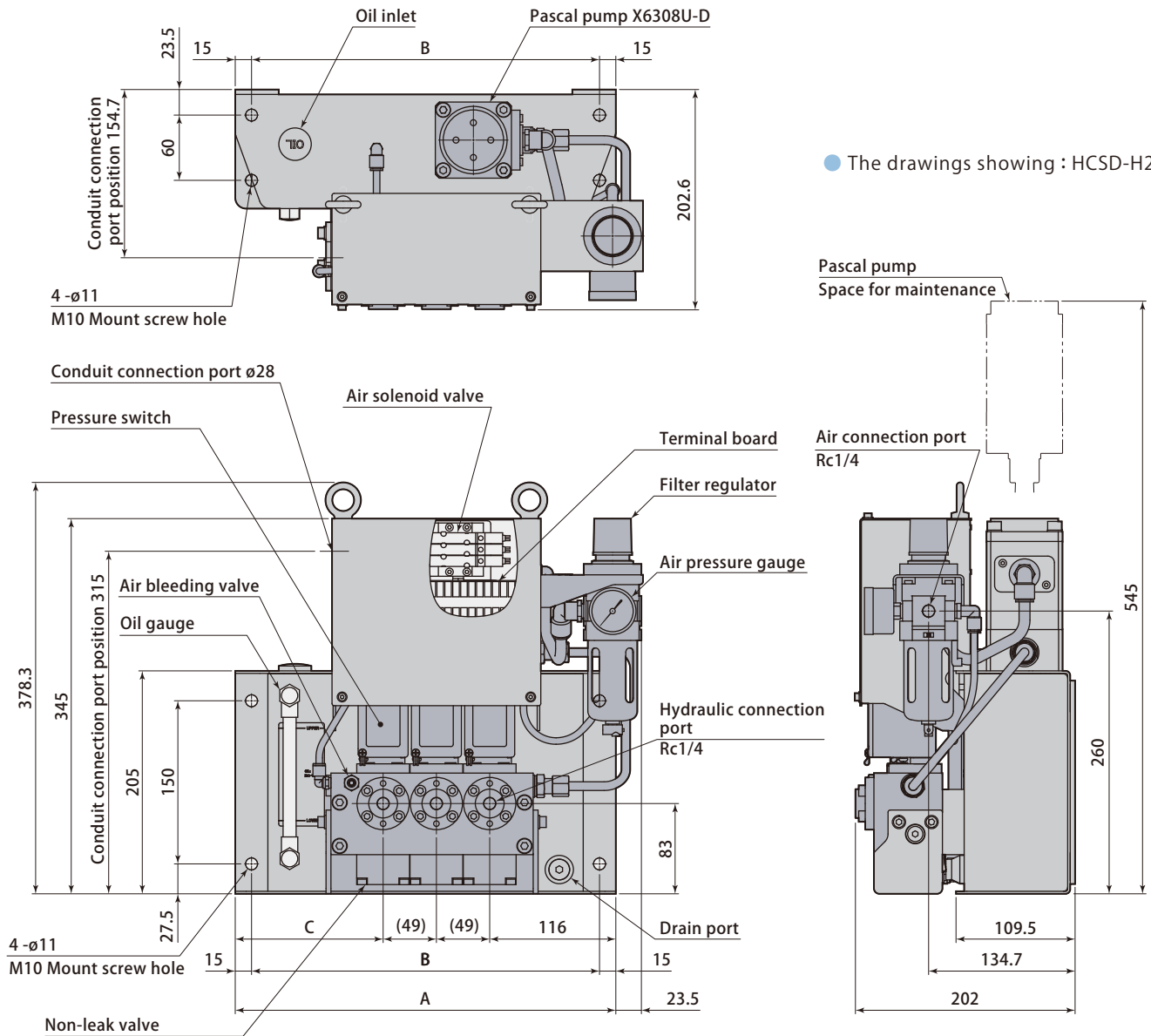

Control unit
HCS

Number of hydraulic circuit		3	4
A	mm	350	400
B	mm	320	370
C	mm	136	137
Weight	kg	22	25

Orifice diameter (Option 4 pieces)

model ZPS-B5

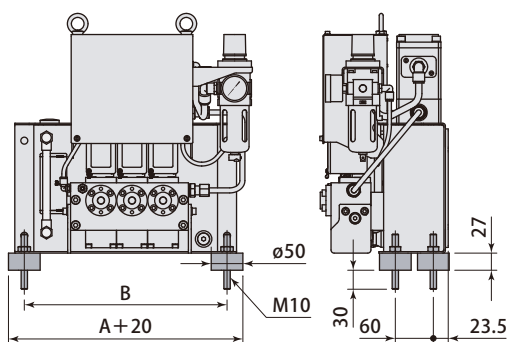

Stand (Option)

model ZPS-S0

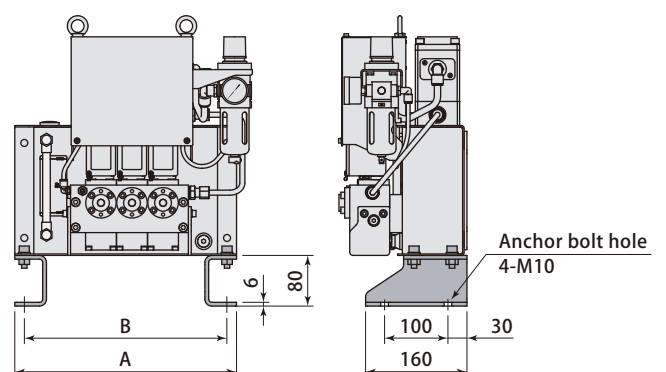



Model designation

HCM D - H3 C S S - L

Control voltage DC24V

*It can not correspond to voltage other than DC24V.

1 Discharge pressure and Pascal pump quantity

2 C port

3 Number of hydraulic circuit
* Indicated in 2-4 alphabets.

4 Special type

1 Discharge pressure × Pump quantity

H2 : 24.5MPa × 1unit

H3 : 15.6MPa × 1unit

H22 : 24.5MPa × 2units

H33 : 15.6MPa × 2units

2 C port
(with in-line filter)

□ : No C : Yes

It corresponds only to HCMD-H3 / HCMD-H33

3 Hydraulic circuits

S

Clamp circuit

Double solenoid valve +
Relief valve for excessive high pressure

4 Special type

□ : No

L : Equipped with oil level sensor
(Lower level detection)

T2 : Auto slider for vertical stroke /centering cylinder
2-position double air solenoid valve equipped

T3 : Auto slider for horizontal stroke
3-position center exhaust air solenoid valve equipped

Hydraulic and air pressure circuit

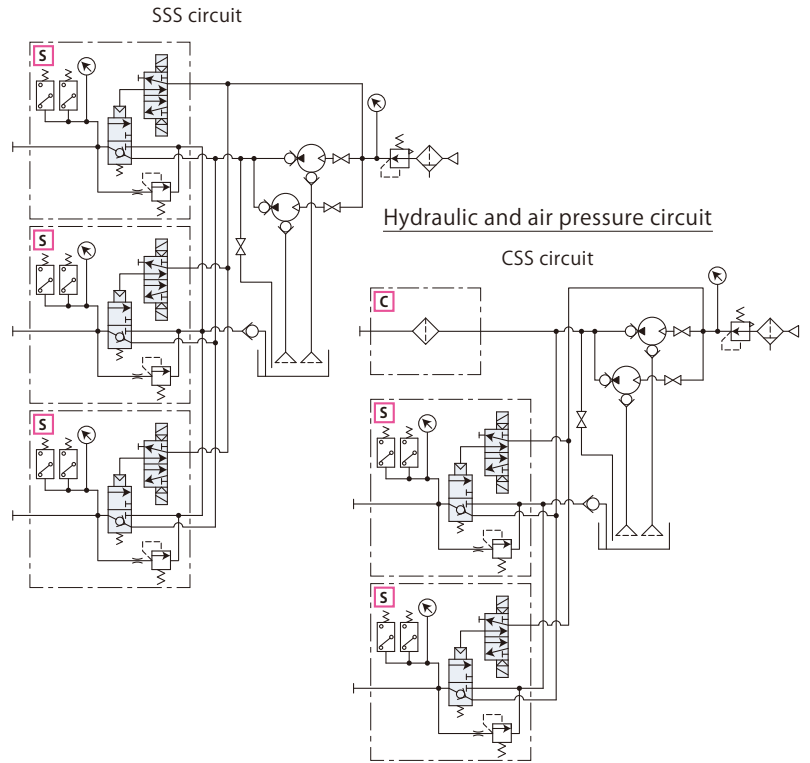

Specifications

Model	HCMD-H2□-□	HCMD-H22□-□	HCMD-H3□-□	HCMD-H33□-□
Pump quantity	1 unit	2 units	1 unit	2 units
Valve switching system	Pilot air			
Discharge pressure	MPa 24.5		15.6	
Driving air pressure	MPa 0.47		0.47	
Discharge volume (at no load)	L/min 1.3	2.6	2	4
Oil tank capacity	L HIGH-LEVEL : 5.4		LOW-LEVEL : 2.2	
Set pressure of digital pressure gauge	MPa 14.7 (INC.) / 30.8 (at excessively high pressure)		8.8 (INC.) / 19.6 (at excessively high pressure)	
Set pressure of relief valve	MPa 27.9		17.6	
Air consumption rate	Nm ³ /min Max. 0.4	Max. 0.8	Max. 0.4	Max. 0.8
Operating temperature	°C 0 ~ 50°C (No freezing)			
Applications (Example)	Clamp model × Quantity	TYA100 × 8 units TYC100 × 8 units	TYA160 × 8 units TYC160 × 8 units	TME025 × 8 units TME040 × 8 units
	HCM model	HCMD-H2SSS	HCMD-H22SSSS	HCMD-H3CSS HCMD-H33CSS

● Fluid used : General mineral based hydraulic oil (ISO-VG32 equivalent)

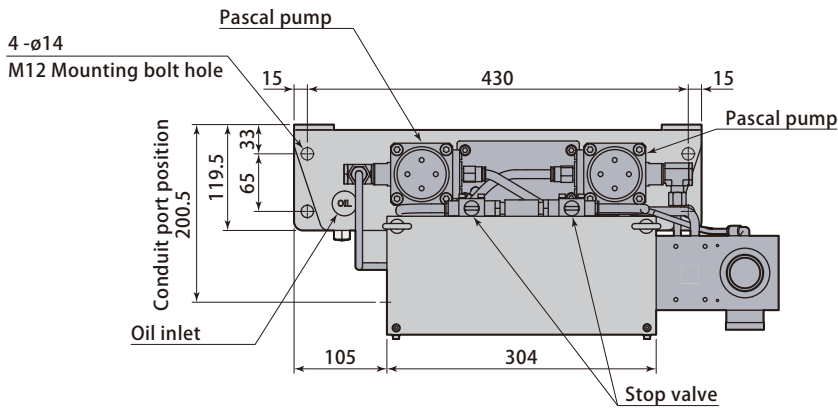

● The drawings showing : HCMD-H22SSS.

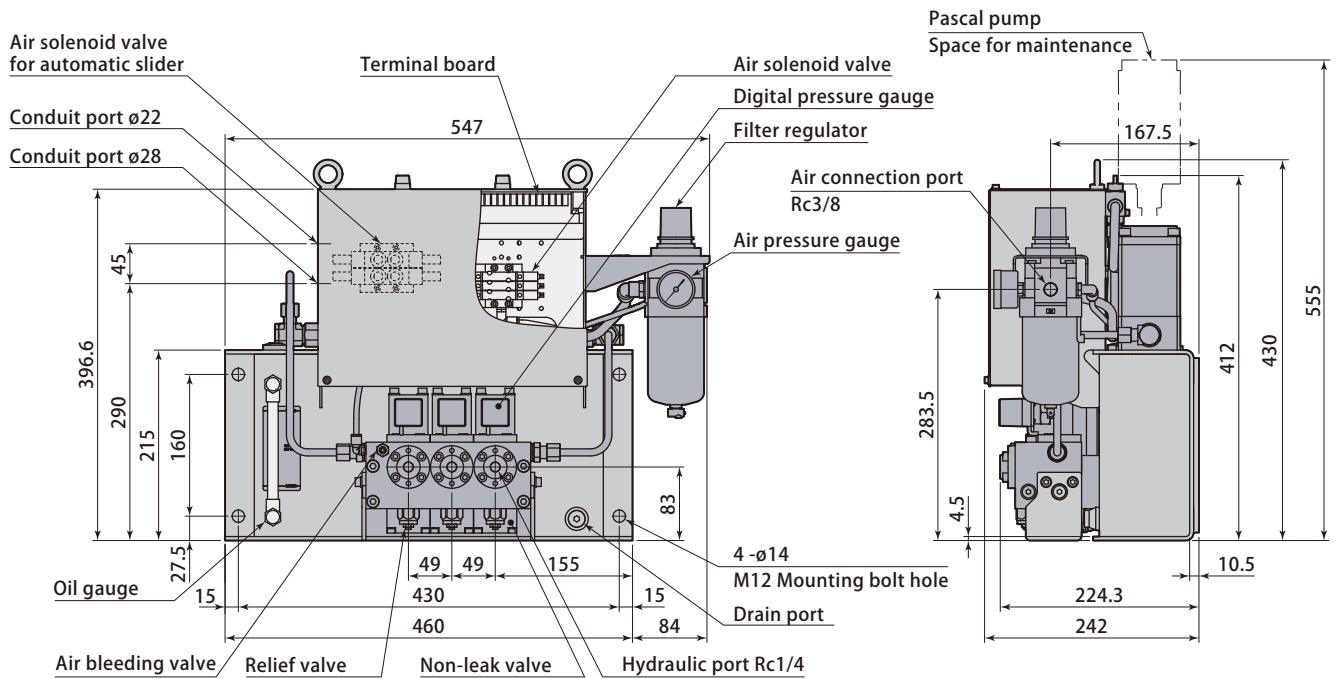

Control unit
HCM

Number of hydraulic circuit		3	4
Weight	kg	32	34

Self-stand (Option)

model ZPS-S1

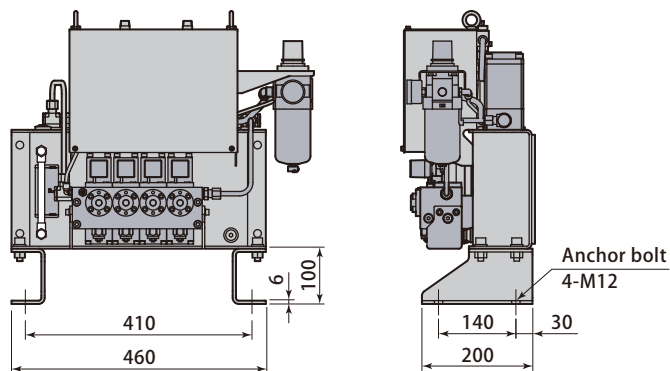



Model designation

HCP D - H3 C S S - U

Control voltage DC24V

* It can not correspond to voltage other than DC24V.

- 1 Discharge pressure and Pascal pump quantity
- 2 C port
- 3 Number of hydraulic circuit
* Indicated in 2-4 alphabets.
- 4 Special type

- 1 Discharge pressure × Pump quantity
 - H2 : 24.5MPa × 1unit H3 : 15.6MPa × 1unit
 - H22 : 24.5MPa × 2units H33 : 15.6MPa × 2units

- 2 C port (with in-line filter)

□ : No C : Yes

It corresponds only to HCPD-H3 / HCPD-H33

- 3 Hydraulic circuits

S
Clamp circuit
Double solenoid valve + Relief valve for excessive high pressure

- 4 Special specifications

- : Without
- L : Low oil level detection switch
- T2 : For auto slider 2-position double air solenoid valve equipped
- T3 : For auto slider 3-position center exhaust air solenoid valve equipped
- U : Oil pressure gauge for each circuit

Hydraulic and air pressure circuit

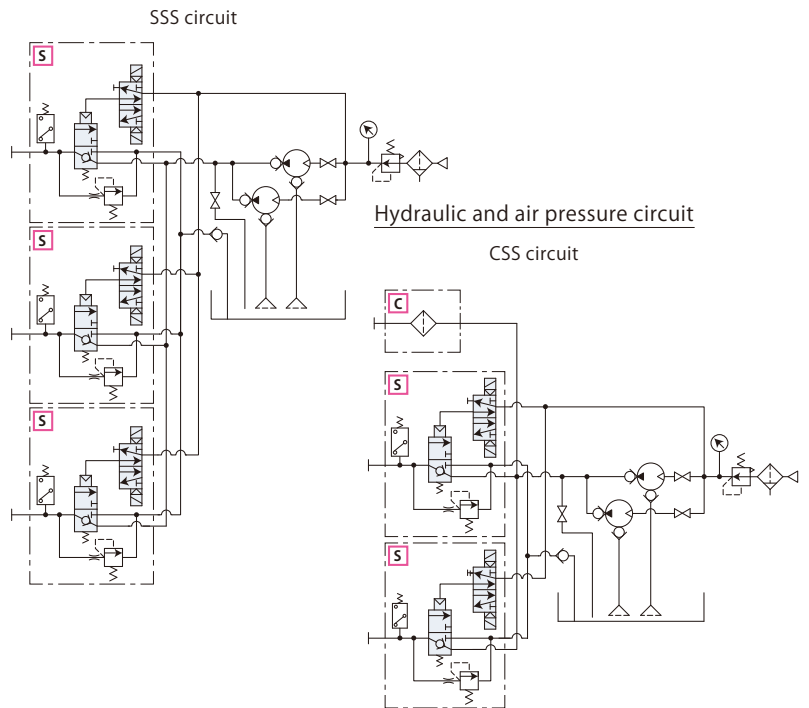

Specifications

Model	HCPD-H2□-□	HCPD-H22□-□	HCPD-H3□-□	HCPD-H33□-□
Pump quantity	1 unit	2 units	1 unit	2 units
Valve switching system	Pilot air			
Discharge pressure	MPa 24.5		15.6	
Driving air pressure	MPa 0.47		0.47	
Discharge volume (at no load)	L/min 1.3	2.6	2	4
Oil tank capacity	HIGH-LEVEL : 5.4		LOW-LEVEL : 2.2	
Set pressure of pressure switch	MPa 14.7 (INC.)		8.8 (INC.)	
Set pressure of relief valve	MPa 27.9		17.6	
Air consumption rate	Nm ³ /min Max. 0.4	Max. 0.8	Max. 0.4	Max. 0.8
Operating temperature	°C 0 ~ 50°C (No freezing)			
Applications (Example)	Clamp model × Quantity	TYA100 × 8 units TYC100 × 8 units	TYA160 × 8 units TYC160 × 8 units	TME025 × 8 units TME040 × 8 units
	HCP model	HCPD-H2SSS	HCPD-H22SSS	HCPD-H3CSS HCPD-H33CSS

- Fluid used : General mineral based hydraulic oil (ISO-VG32 equivalent)
- It does not correspond to digital pressure gauge. If necessary, select model HCM page → 77.

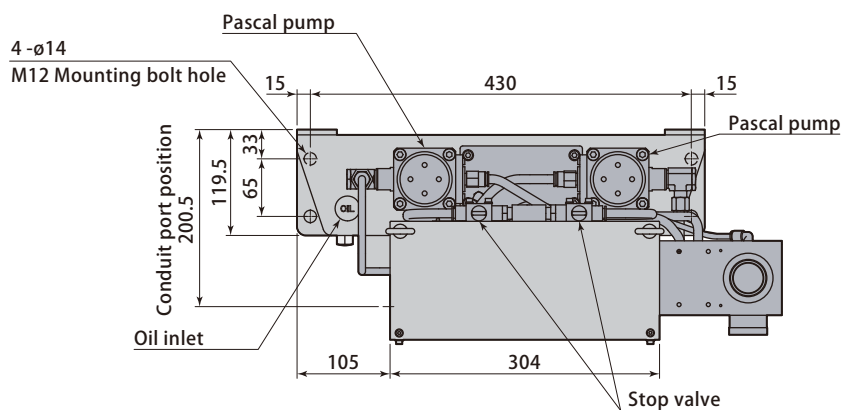

● The drawings showing : HCPD-H22SSS.

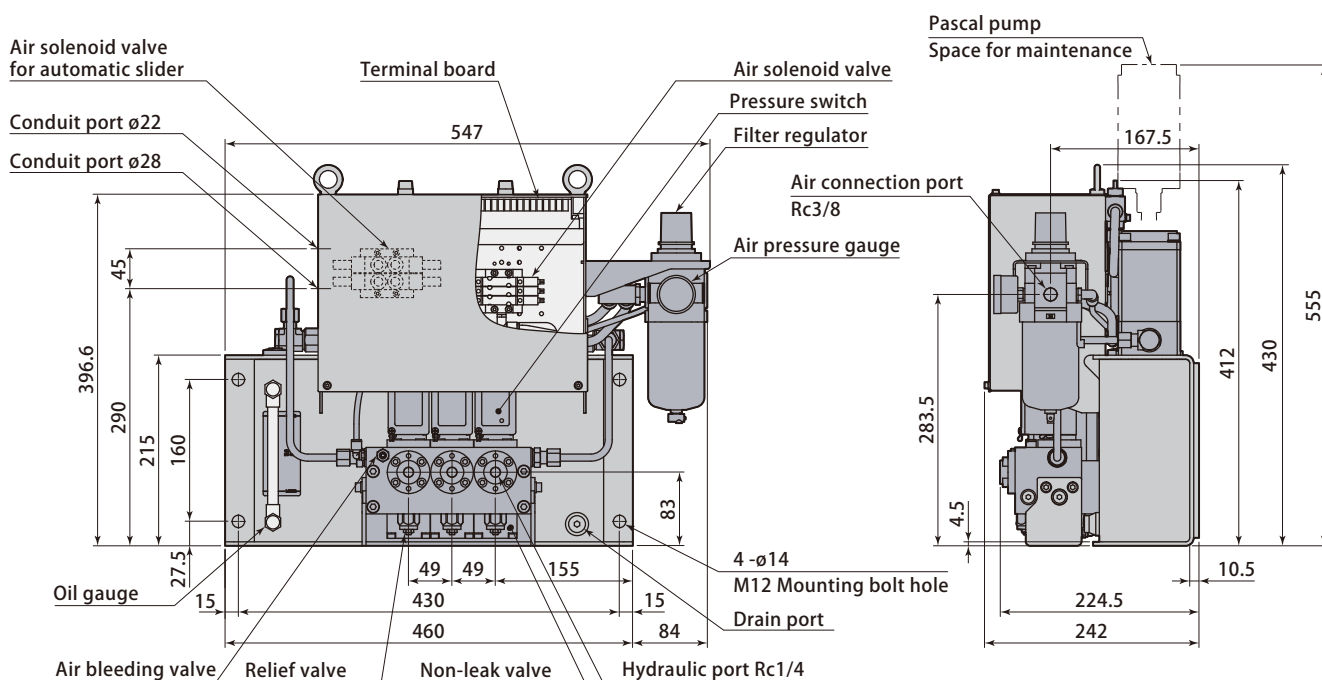

Control unit
HCP

Number of hydraulic circuit		3	4
Weight	kg	35	37

● For the case of double pumps. 3kg to be decreased in case of single pump.

Self-stand (Option)

model ZPS-S1

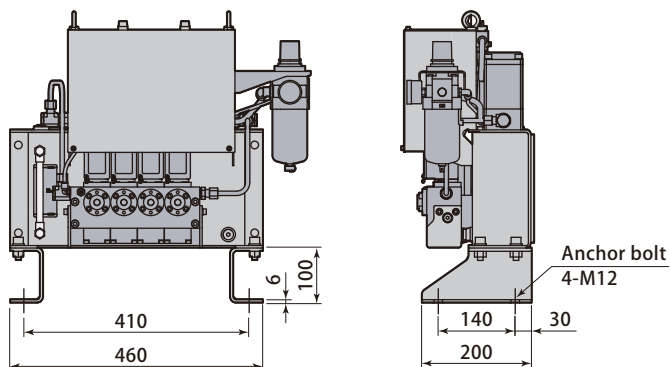

It is utilized to select the hydraulic clamp TKB and to supply the hydraulic pressure source from machine.



Model designation

VSE **D** - H3 **C** **S** **S** **K** - **U**

Control voltage DC24V
*Contact Pascal for other voltage.

C port with inline filter

3 Number of hydraulic circuit
*Indicated in 1-2 alphabets.

With check valve

4 Hydraulic gauge for each circuit

Specifications

Model	VSED-H3C□K	
Working hydraulic pressure (Hydraulic pressure source : IMM)	MPa	13.7
Operating temperature	°C	0 ~ 50 (No freezing)

- Fluid used : General mineral based hydraulic oil (ISO-VG32 equivalent)
- The working hydraulic pressure required for TME is 15.6MPa.
- In case of utilizing Pascal pump in the hydraulic pressure source, select non-leak valve VSB.

3 Hydraulic circuits

S
Clamp circuit
Double solenoid valve + Relief valve for excessive high pressure

4 With hydraulic gauge for each circuit

□ : No

U : Yes

Number of hydraulic circuit		1	2
A	mm	160	210
B	mm	120	170
Weight	kg	11.5	15.5

Hydraulic and air pressure circuit

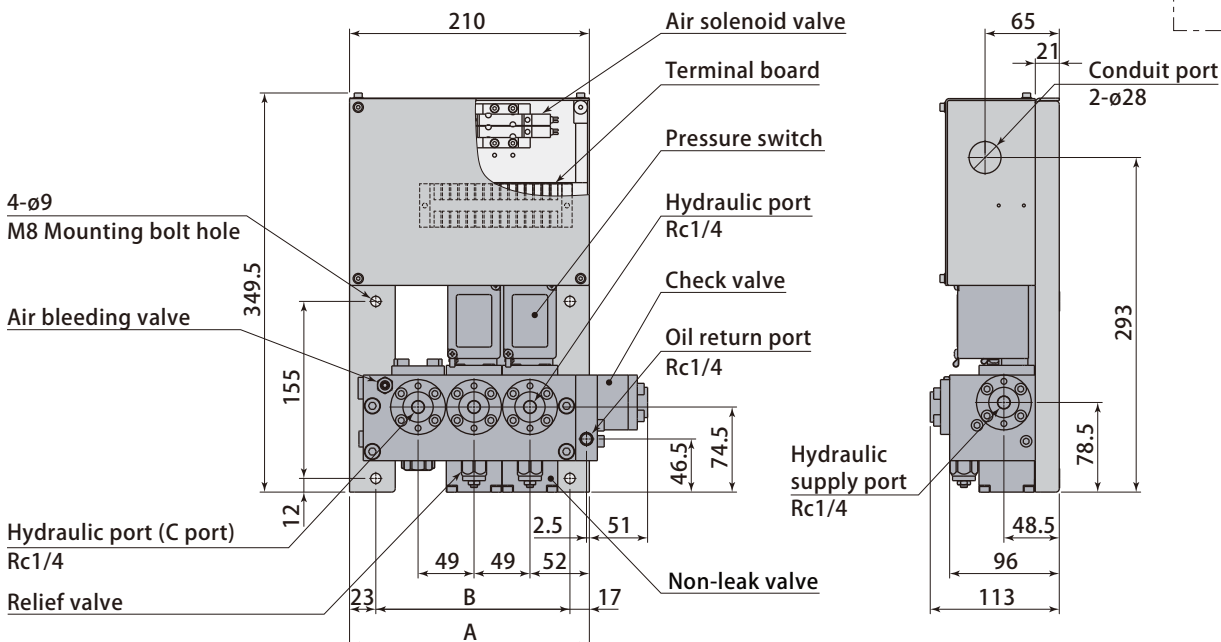
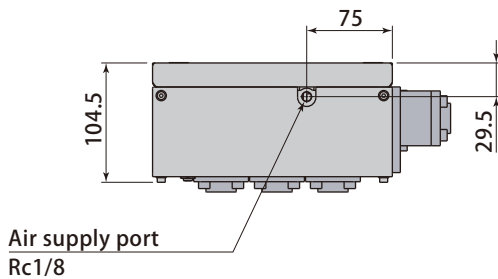
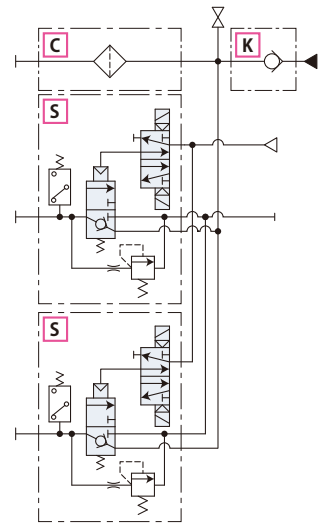

Non-leak valve unit VSE

For large volume oil circuit



It is utilized to select the hydraulic clamp TKB and to supply the hydraulic pressure source from machine.

Specifications

Model		VSL3D-LR-CK
Working hydraulic pressure (hydraulic pressure source : IMM)	MPa	13.7
Operating temperature	°C	0 ~ 50 (No freezing)
Orifice area	mm ²	Discharge : 78.5 / Return : 55

- Fluid used : General mineral based hydraulic oil (ISO-VG32 equivalent)
- The working hydraulic pressure required for TME is 15.6MPa.

Model designation

VSL 3 D - LR - C K

- Control voltage DC24V
*Contact Pascal for other voltage.
- 3 Number of hydraulic circuit
- C port with inline filter
- With check valve

3 Hydraulic circuit

Symbol	LR
Number of circuit	1
Clamp circuit	Double solenoid valve + Relief valve for excessive high pressure

Hydraulic and air pressure circuit

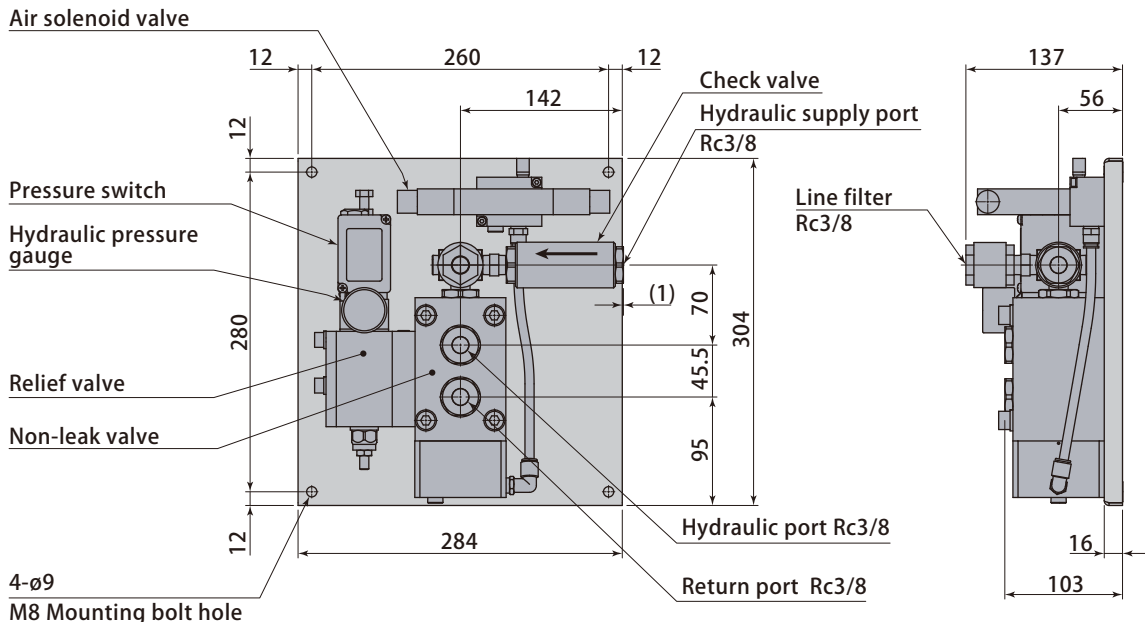
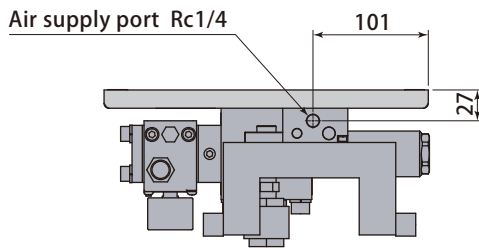
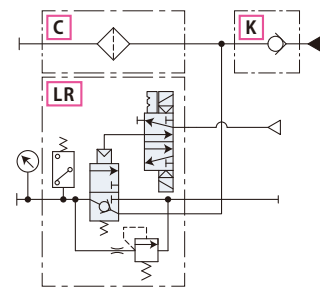

Non-leak valve unit VSL

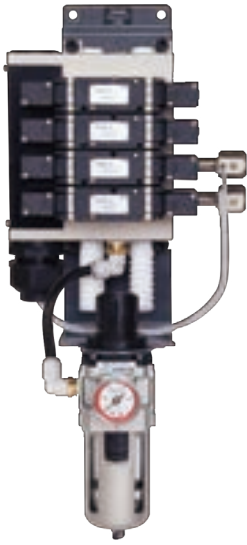

Model designation

GSC D - 1 L L T T

Control voltage DC24V
* Contact Pascal for other voltage.

- 1 Air clamp model (size)
 - 2 Pneumatic circuit
- * Indicated in 1-4 alphabets.

Air pressure circuit

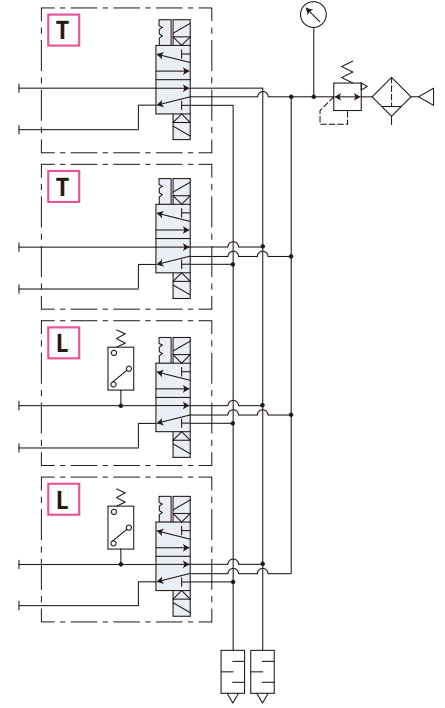

- 1 Air clamp model (size) *
 - 1 : 010 016 025 040 063
 - 2 : 100 160 250

* Applicable clamp size shown are for the case when 4 clamps are used per one circuit. When 5 clamps are being used per one circuit, contact Pascal for details.

2 Pneumatic circuit

Number of pneumatic circuit		Pneumatic circuit symbol
Clamp circuit	Slider circuit	
1	—	L
2	—	LL
3	—	LLL
2	2	LLTT

Clamp circuit : L Slider circuit : T

Specifications

Model	GSC□-1□	GSC□-2□
Fluid used	Air	
Type of seal	Metal seal	
Solenoid valve	2 Position Double	
Max. operating pressure	MPa	0.7
Proof pressure	MPa	1
Fluid temperature range	°C	5 ~ 50
Orifice area	mm ²	15 32.4
Air piping diameter	ø6	ø10
Protection structure	Dust Proof	
Oil supply	Nil	

● The minimum air pressure necessary for unclamp action is 0.39 MPa. Be sure to use at more than 0.39 MPa air pressure.

GSC□-1□

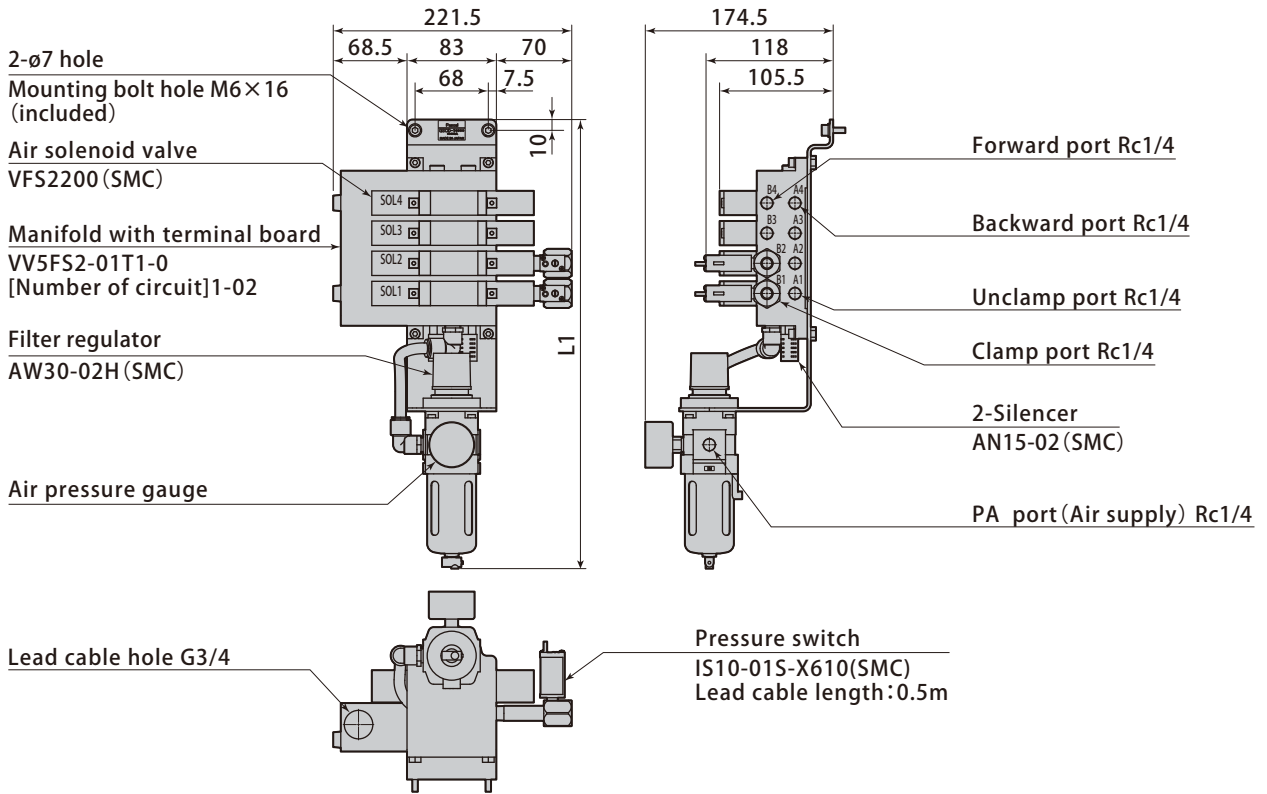

GSC□-2□

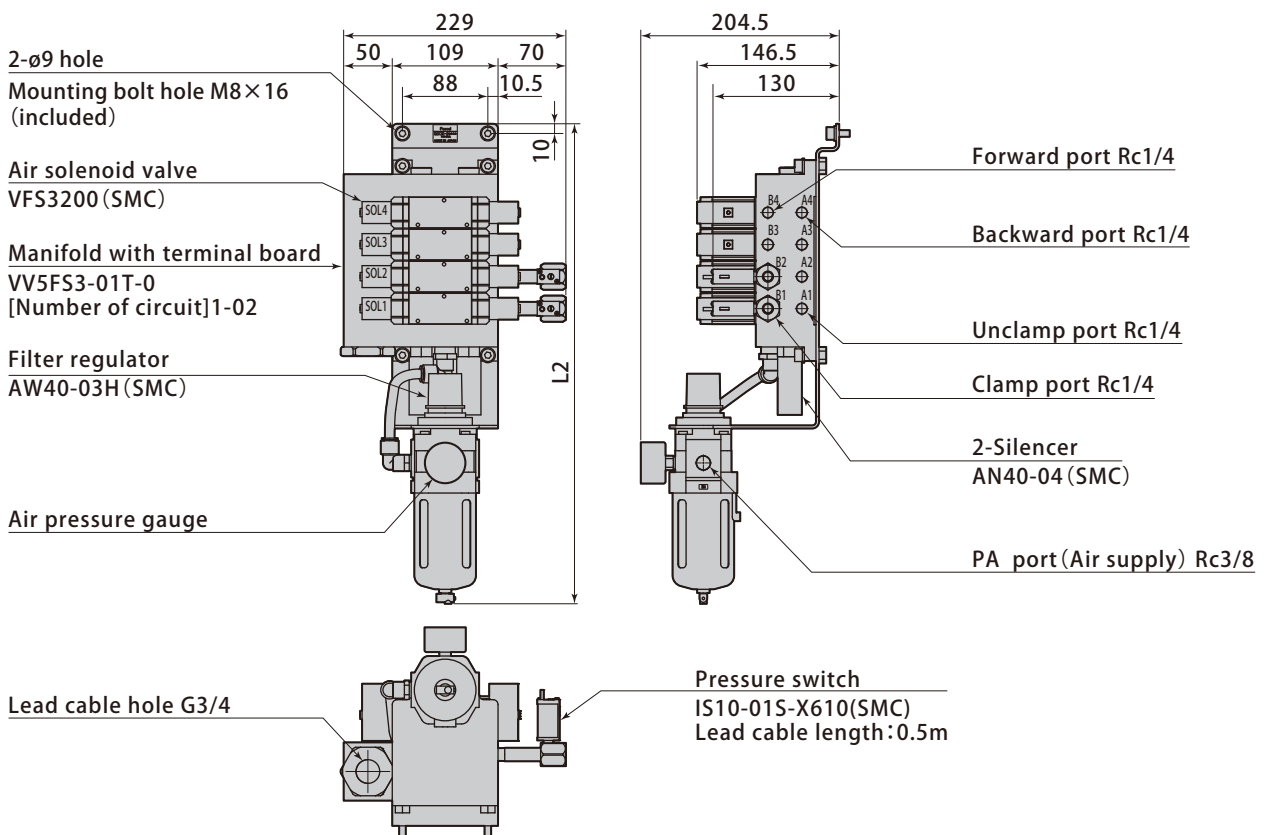

Number of pneumatic circuit		1	2	3	4
GSC□-1□	L1 mm	361	361	389	417
	Weight kg	3.8	4	4.3	4.7
GSC□-2□	L2 mm	429	429	462	495
	Weight kg	5.5	5.7	6.5	6.9

Operation panel

User friendly control panels with compact body and high visible indication.
It is mountable on IMM or wall of IMM utilizing the tap holes at the rear side. (M4 bolts x 4 accessories)

[For vertical loading]

model ESTE-A



[For horizontal loading]

model ESTE-B



Model	ESTE-A	ESTE-B
Loading direction	Vertical loading	Horizontal loading
Weight	kg 0.6	0.6

Mounting bracket

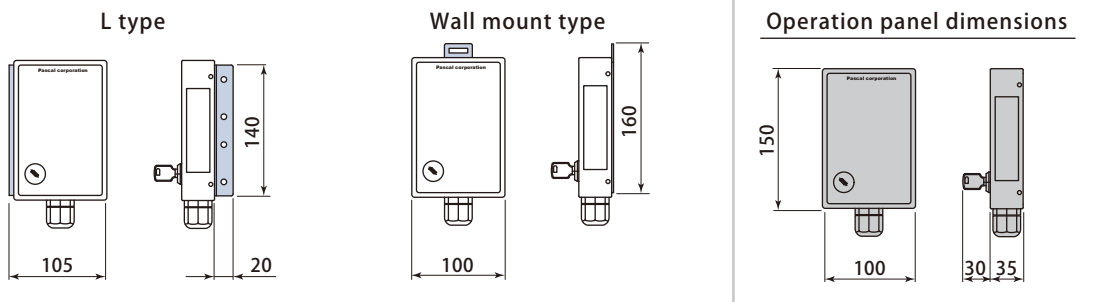

Operation panel
ESTE

Control box

model ECTL

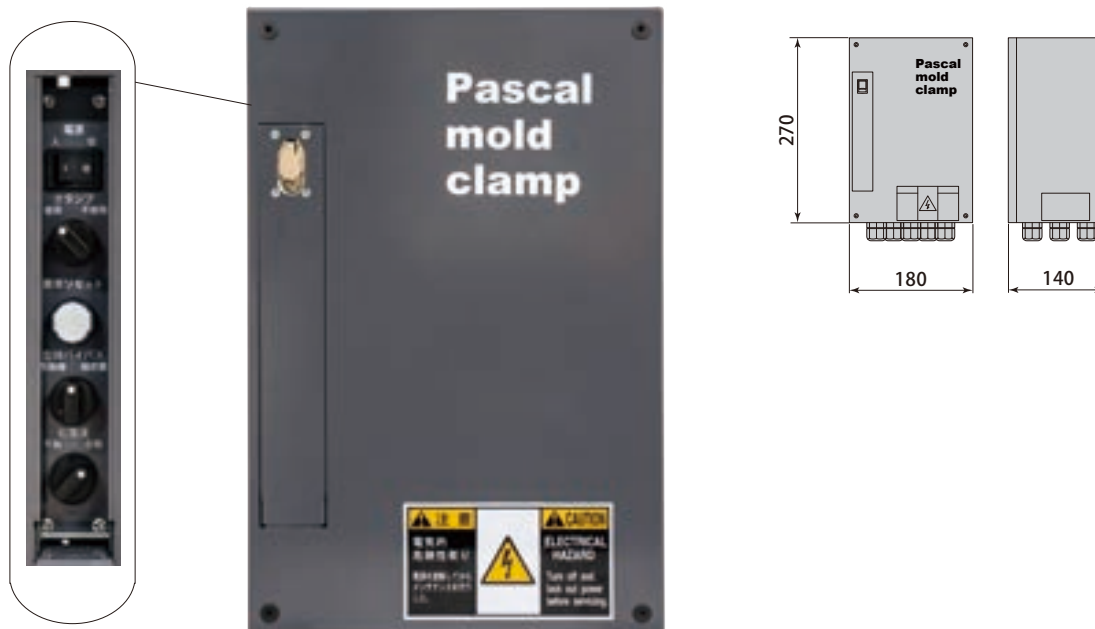

Model	ECTL	
Weight	kg	4

Mounting bracket

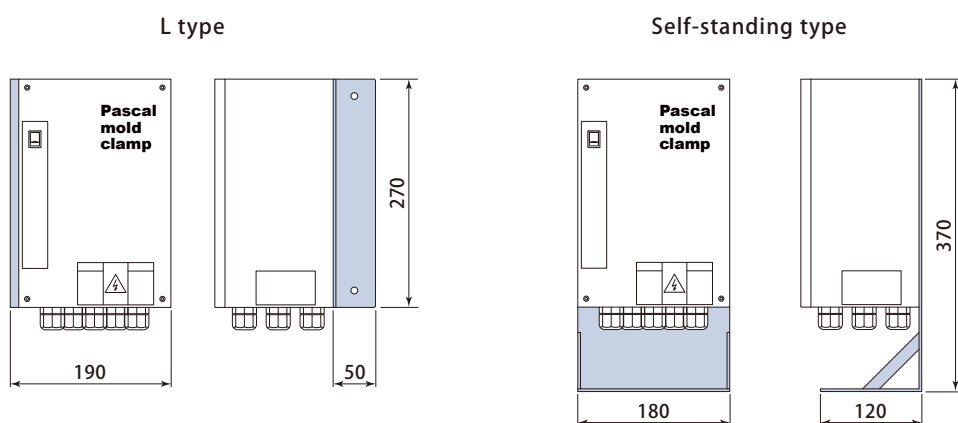

Interlock

The following interlock is incorporated into the electric control circuit for hydraulic and air clamp, so the mold changing operation can be performed safely.

- The operation of hydraulic and air clamp is feasible when all of conditions ①~⑥ shown below have become complete at time of mold changing.

Hydraulic/Air clamp : ①Mold changing

IMM : ②Set up mode(or manual mode), ③Injection nozzle retract back, ④Ejector retract back,
⑤Mold clamped by platen, ⑥Safety door

Regarding the condition of IMM side such as ②, ③ and ⑤, it can be confirmed with LED lamp on operation panel.

New proposal in place of conventional locate ring

Introducing a Die setter, the horizontal and vertical positioning can be determined surely and easily by placing a mold on a Die setter and it improves the productivity and set up.

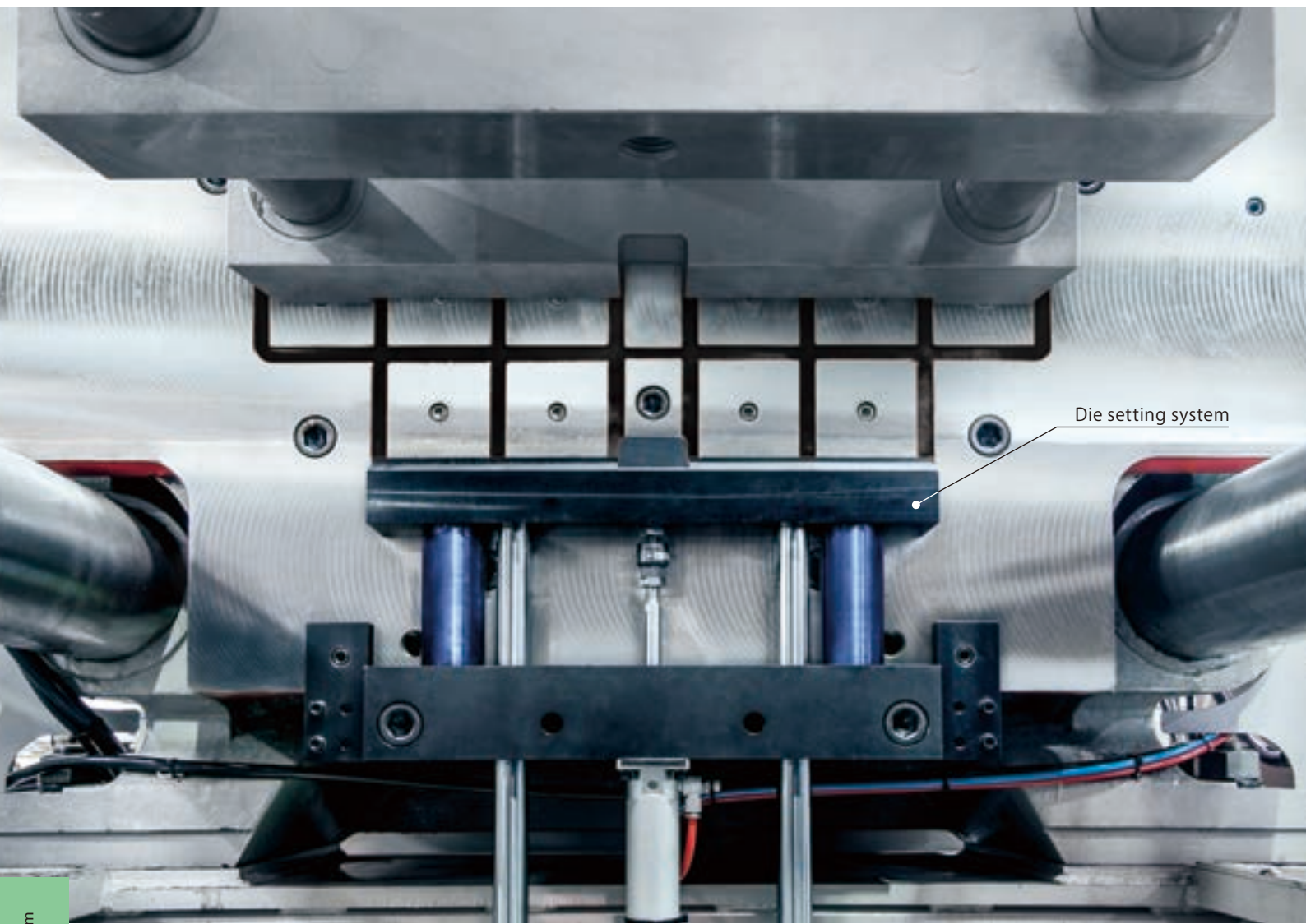

Die setting system

3,500kN (350ton) IMM vertical loading Die setting system & Mag clamp

Die setter operation panel



Die setter operation panel

The lift of Die set block is operated. It is mountable near the IMM control panel with L type bracket.

Die setter & Clamp operation panel



Clamp operation button
Die setter operation button

There is also a model integrated with clamp and die setter. Contact Pascal for details.

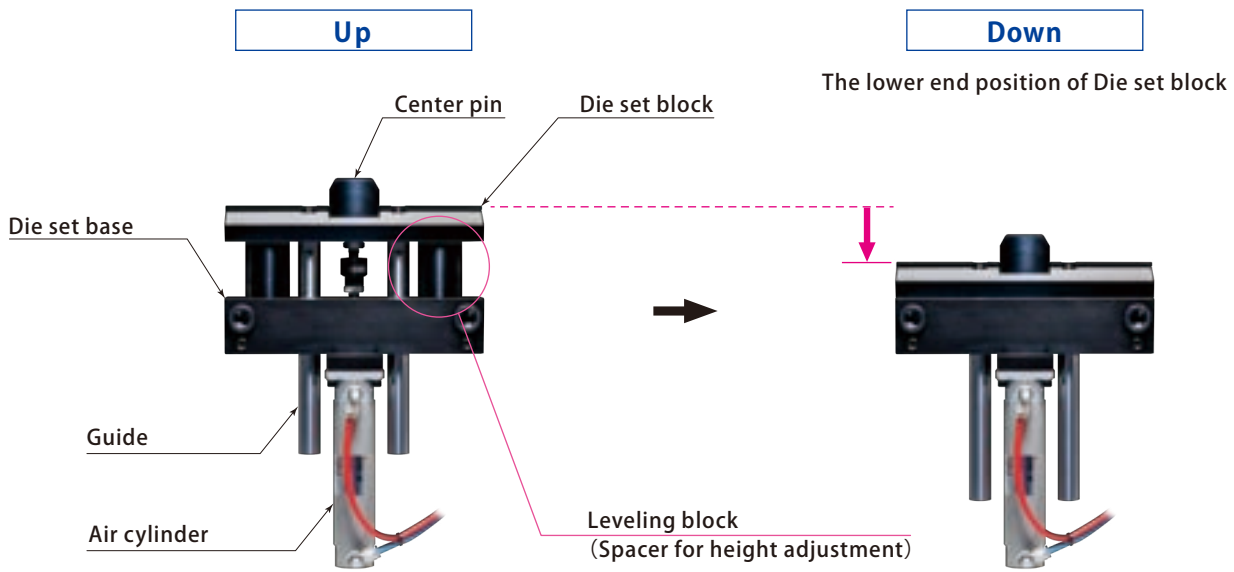

Leveling block

Positioning by putting leveling block between a die set block and die set base.



Model designation

MDL 01 A

1 Die setter block type

A : Fixed side (with center pin)

B : Movable side (without center pin)

2 Mold weight

Model		MDL01	MDL03	MDL04	MDL06	MDL10	MDL15	
2	Mold weight	kg	1000	3000	4000	6000	10000	15000
Applied IMM	Clamping force	kN (ton)	1000 (100)	2300 (230)	3500 (350)	6500 (650)	8500 (850)	10500 (1050)
	Loading direction		Vertical loading, Horizontal loading					

● Leveling block is attached. (2pcs)

Die setting with locate ring

Mold center (X,Y) is not stable.

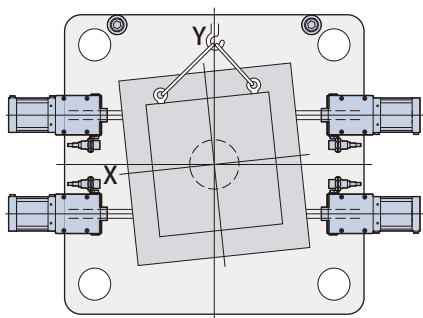

Hard to load the mold

(Visual confirmation from back side of platen (nozzle side) due to the shape of locate ring/Risk of damage of platen or mold when mold loading)

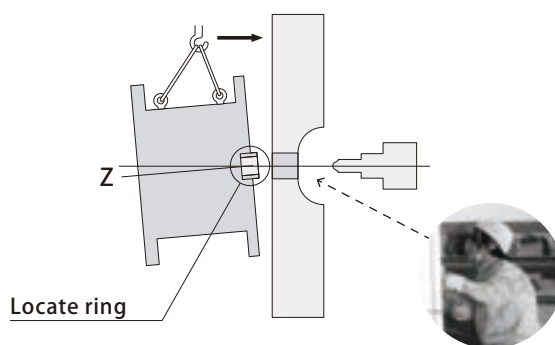

Die setting with die setter

Mold center (X,Y) is quickly secured.

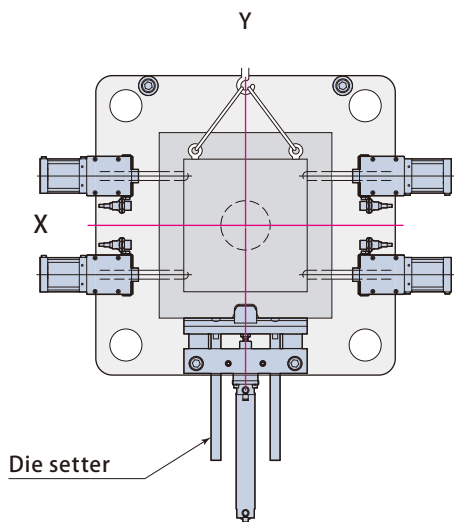

By placing the mold on the die setter, die setting is easy.

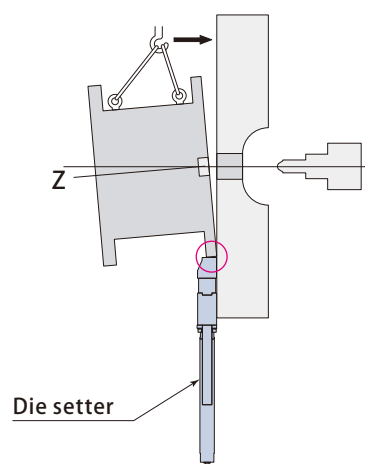

Die setting system MDL

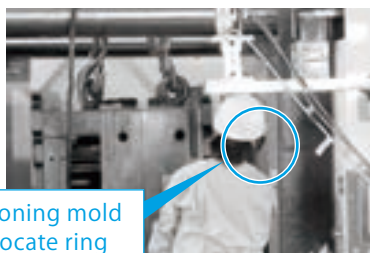

Positioning mold with locate ring :Unnecessary

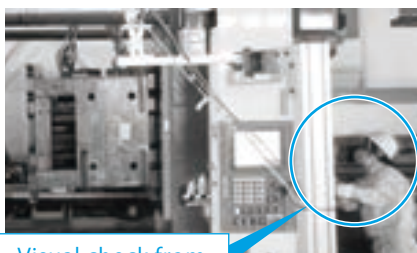

Visual check from injection unit side :Unnecessary



Mold leveling :Unnecessary

Die setting system & Automatic clamp (vertical loading)

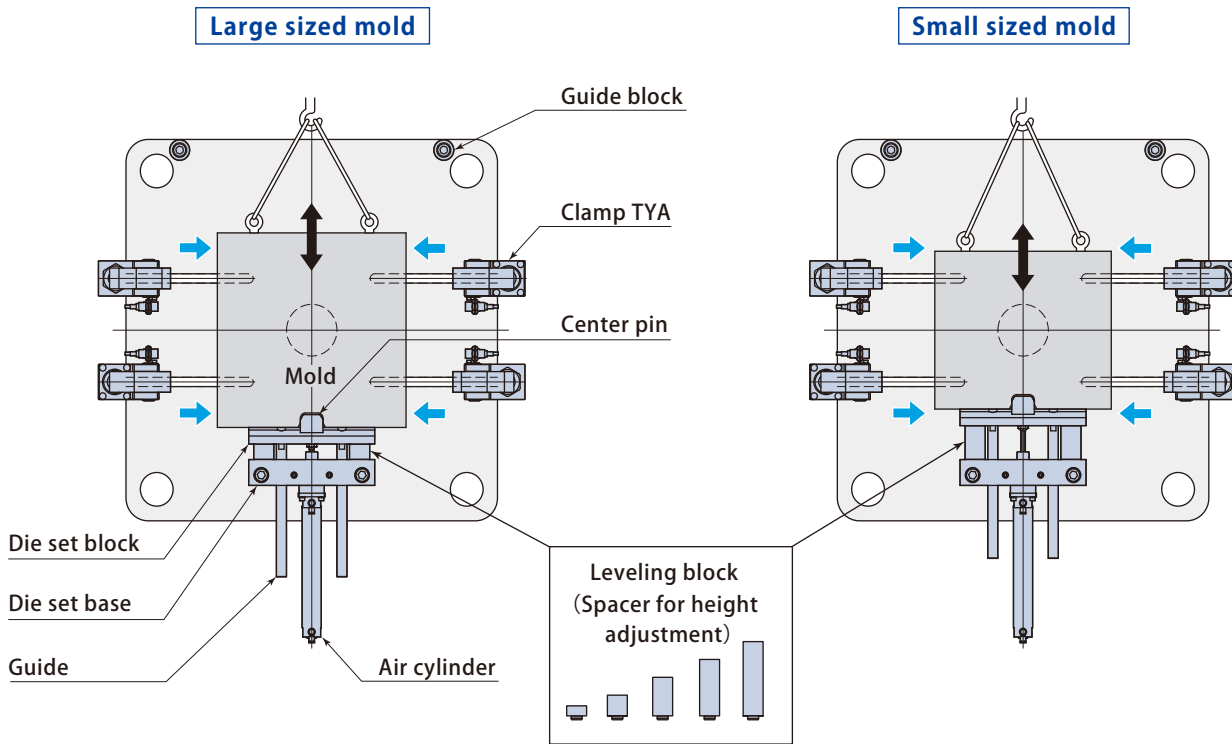

Die setting system & Mag clamp (vertical loading)

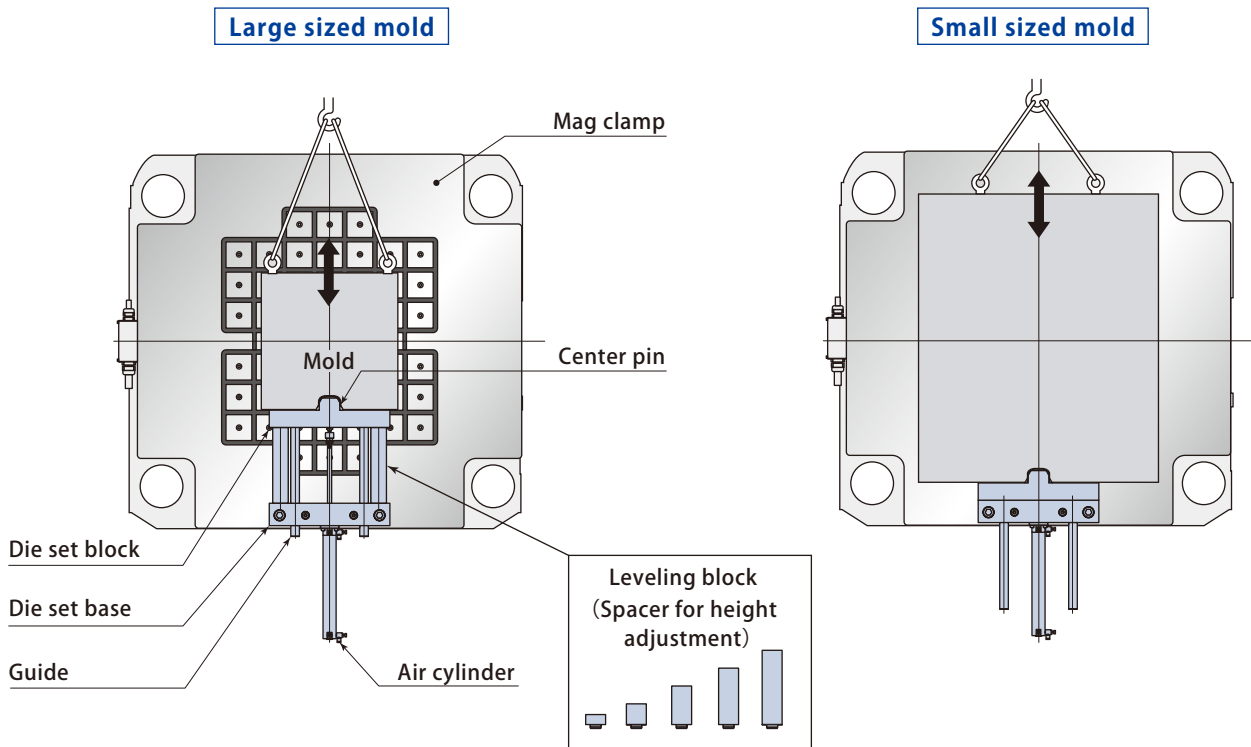

Die setting roller & Mag clamp (horizontal loading)

Small sized mold

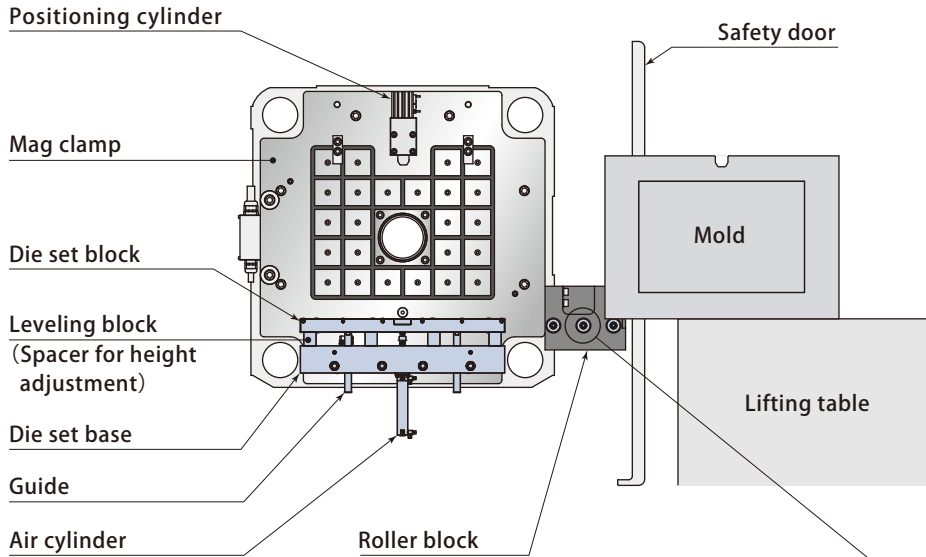

Large sized mold

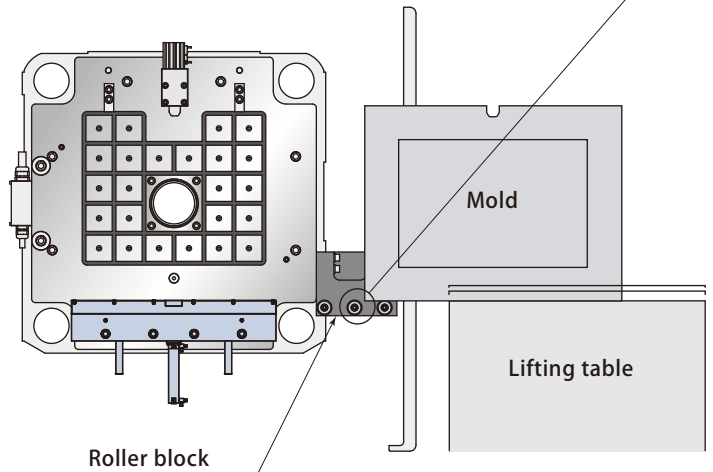

No modification is required on mold.
Just replacing rollers to another
position according to the transport
level.

Transport level change

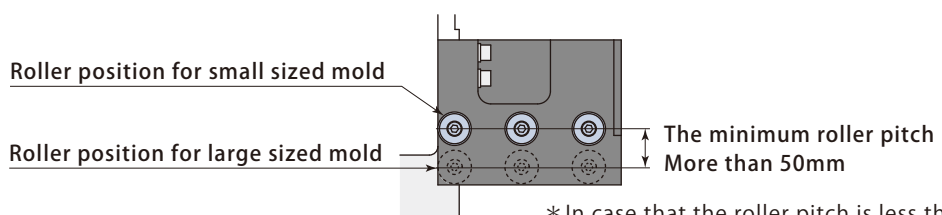

* In case that the roller pitch is less than 50mm,
contact Pascal for details.

In standard horizontal mag clamp system

A **spacer should be attached** to the mold to match the transport level.

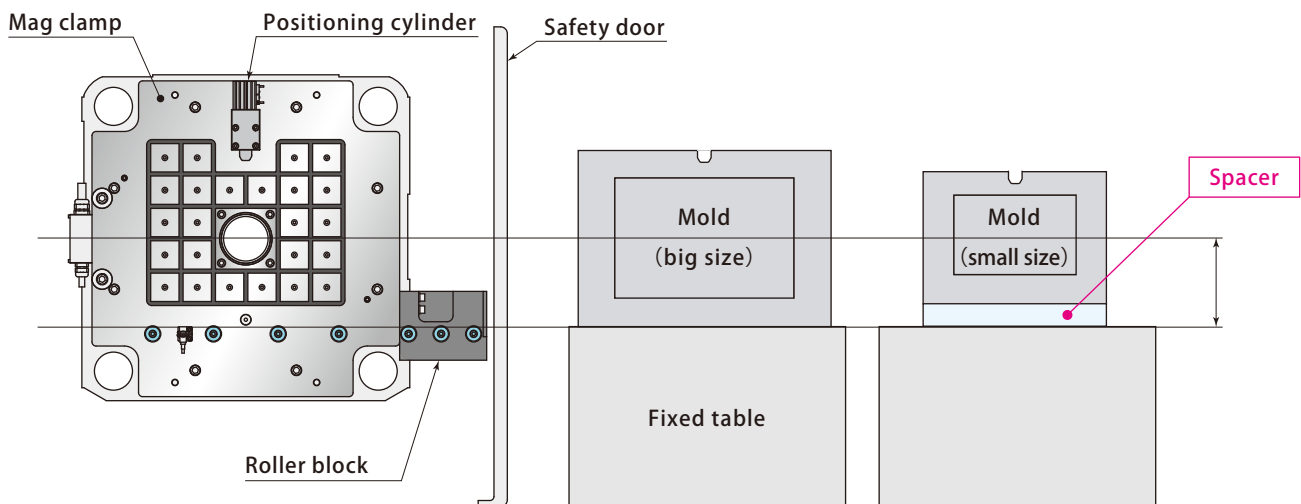

MDL01A (for fixed platen)

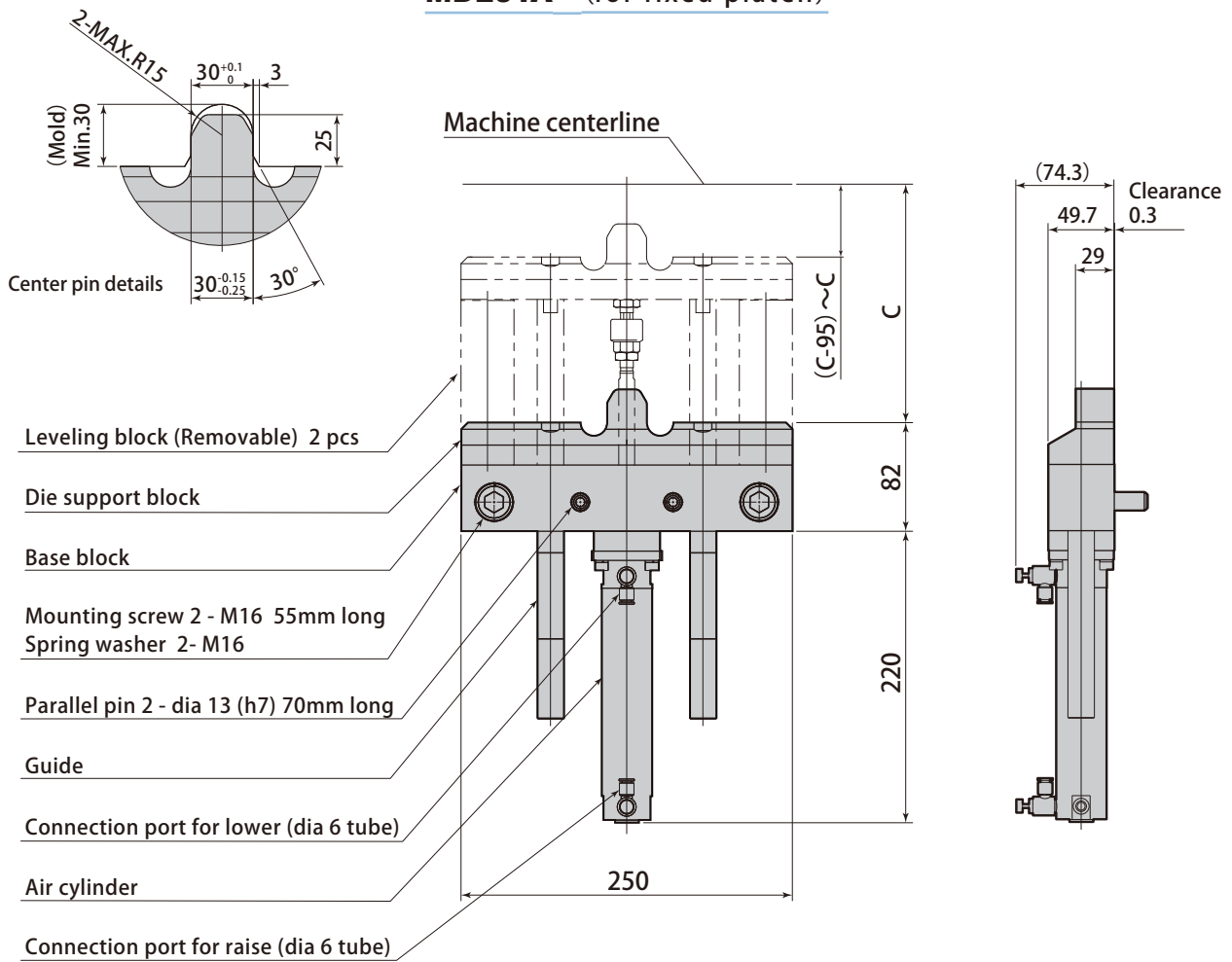

MDL01B (for movable platen)

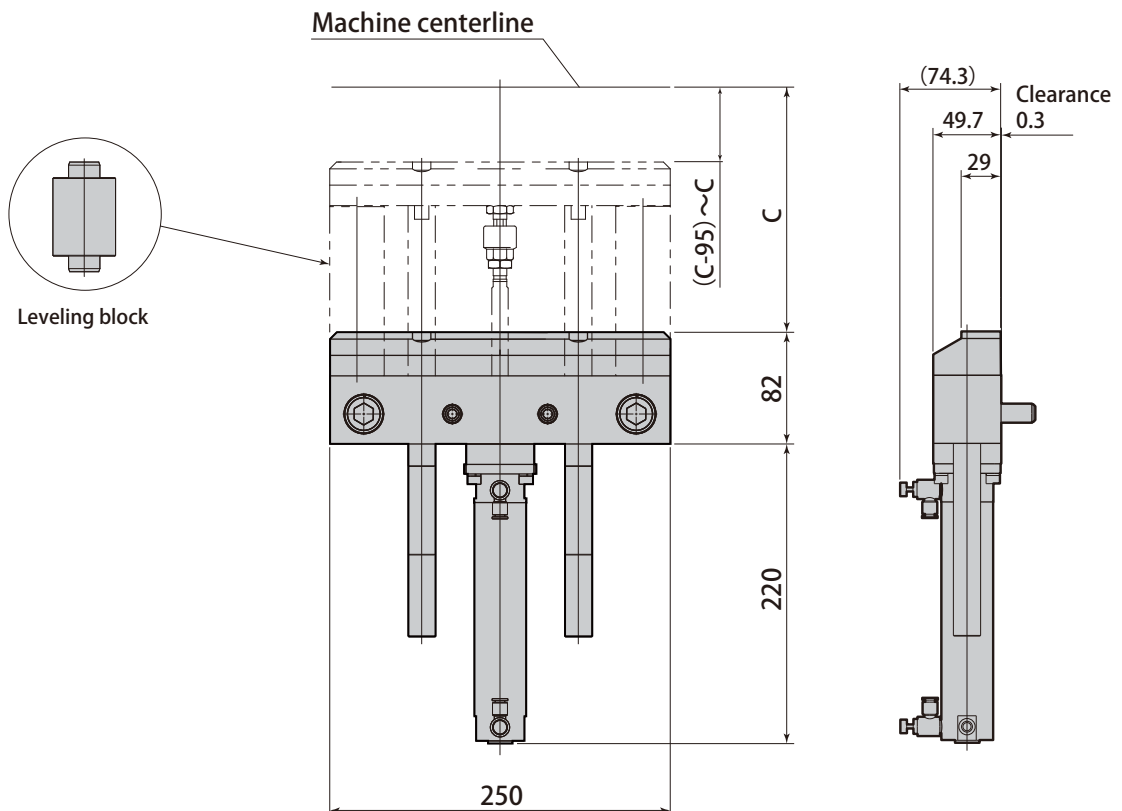

MDL03A (for fixed platen)

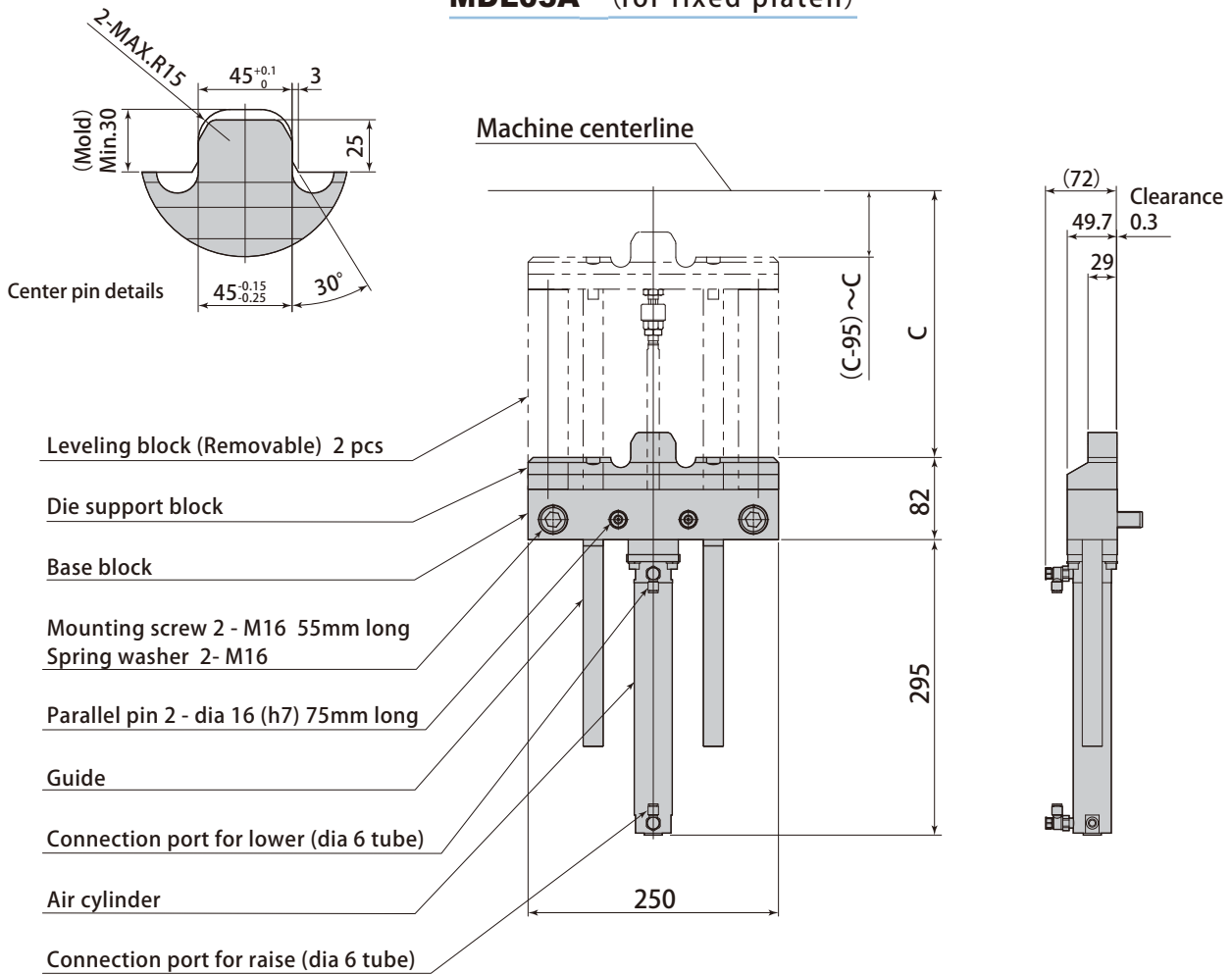

MDL03B (for movable platen)

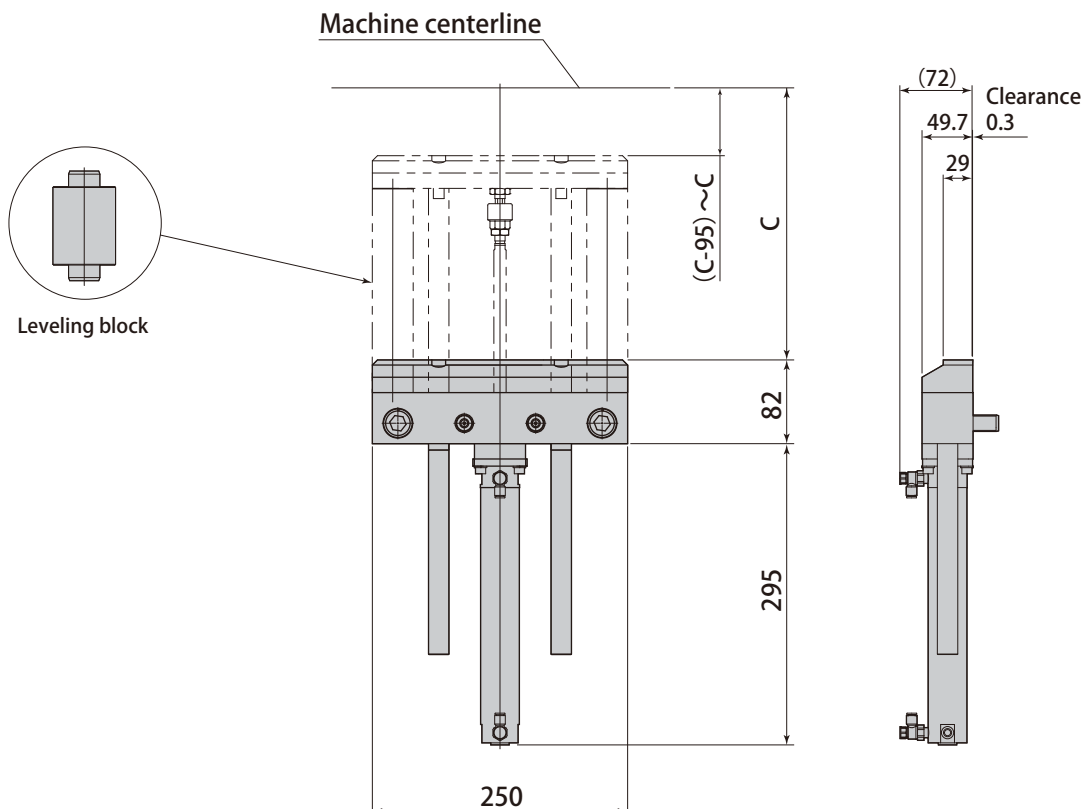

MDL04A (for fixed platen)

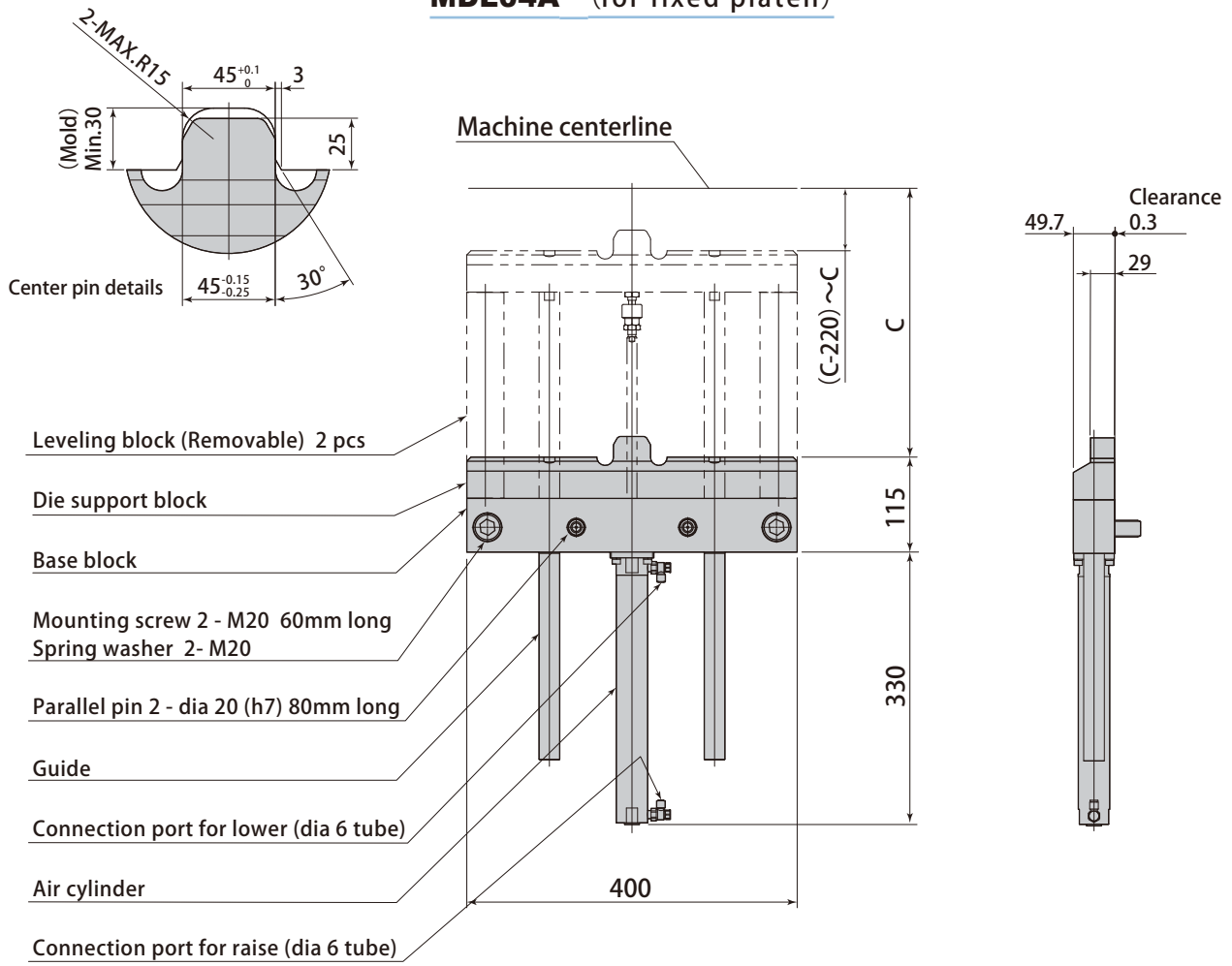

MDL04B (for movable platen)

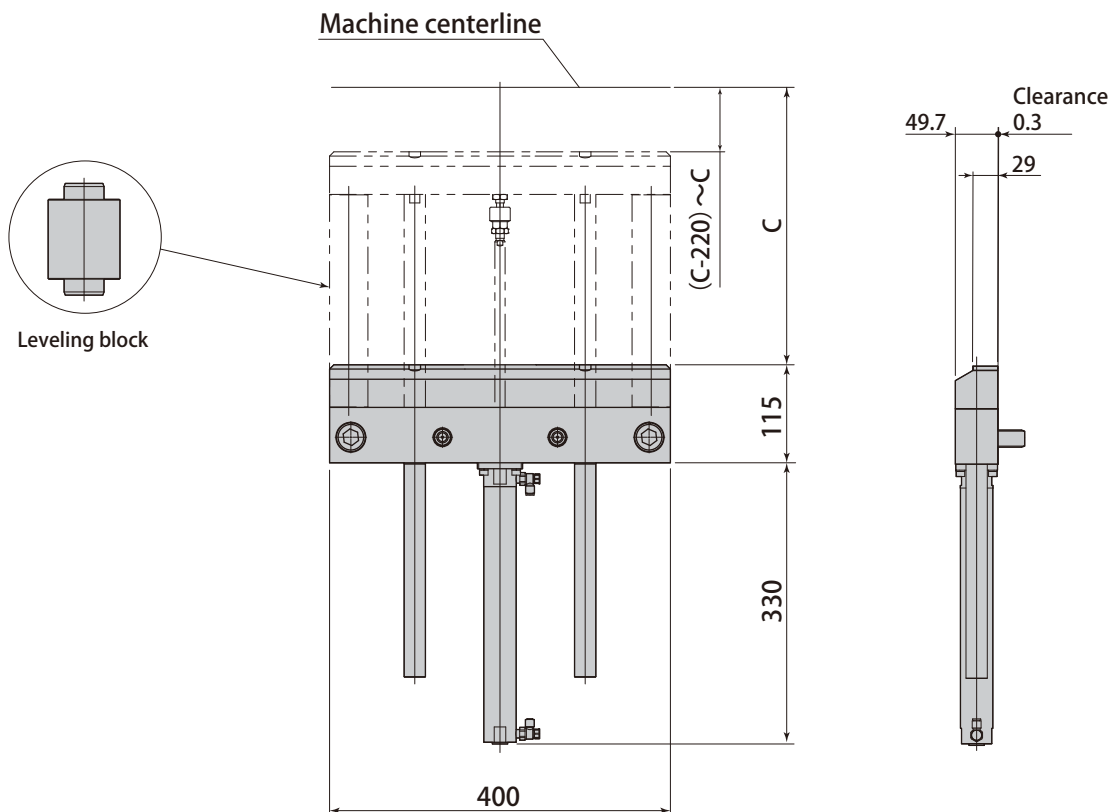

MDL06A (for fixed platen)

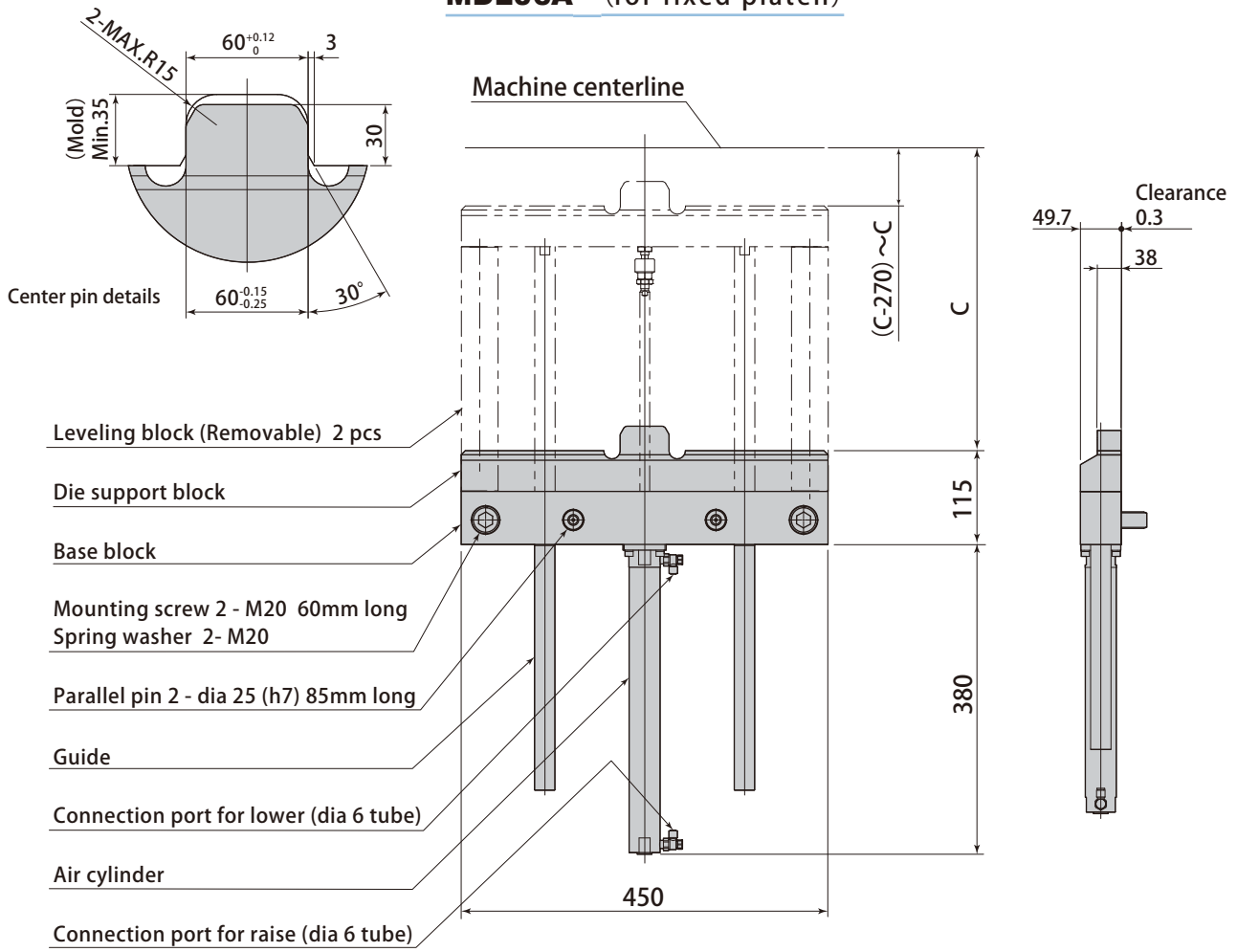

MDL06B (for movable platen)

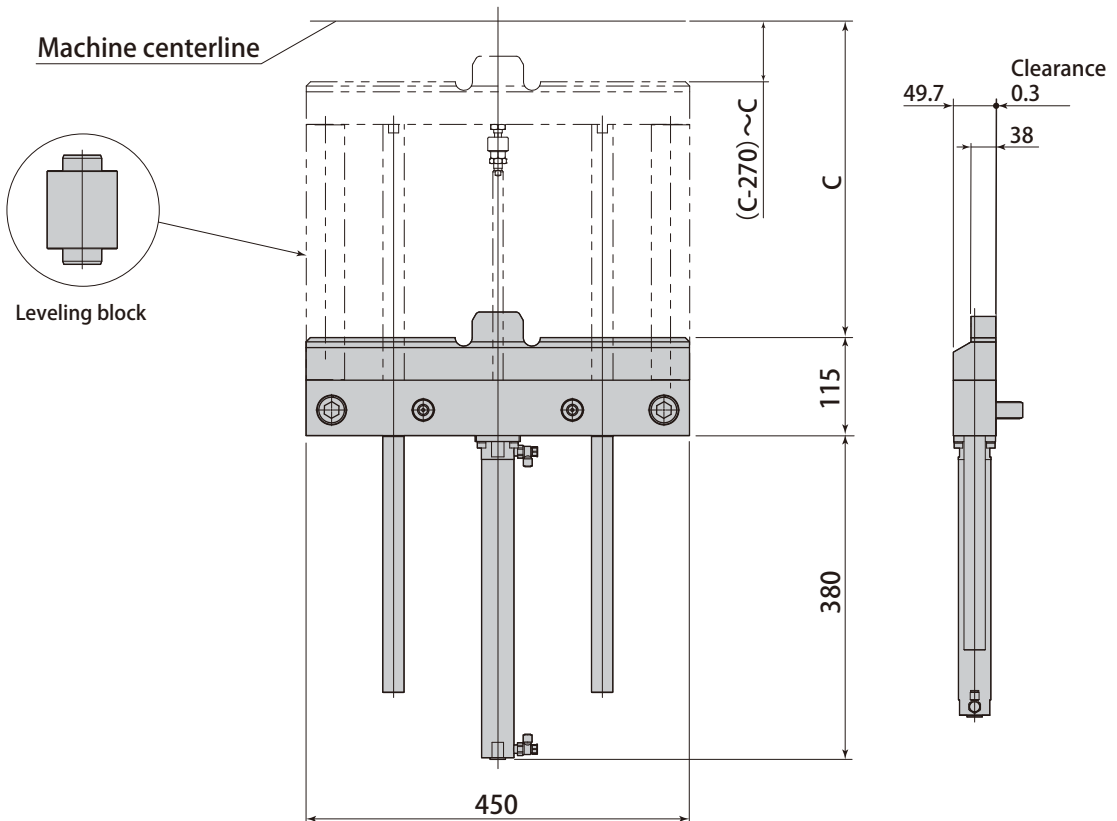

MDL10A (for fixed platen)

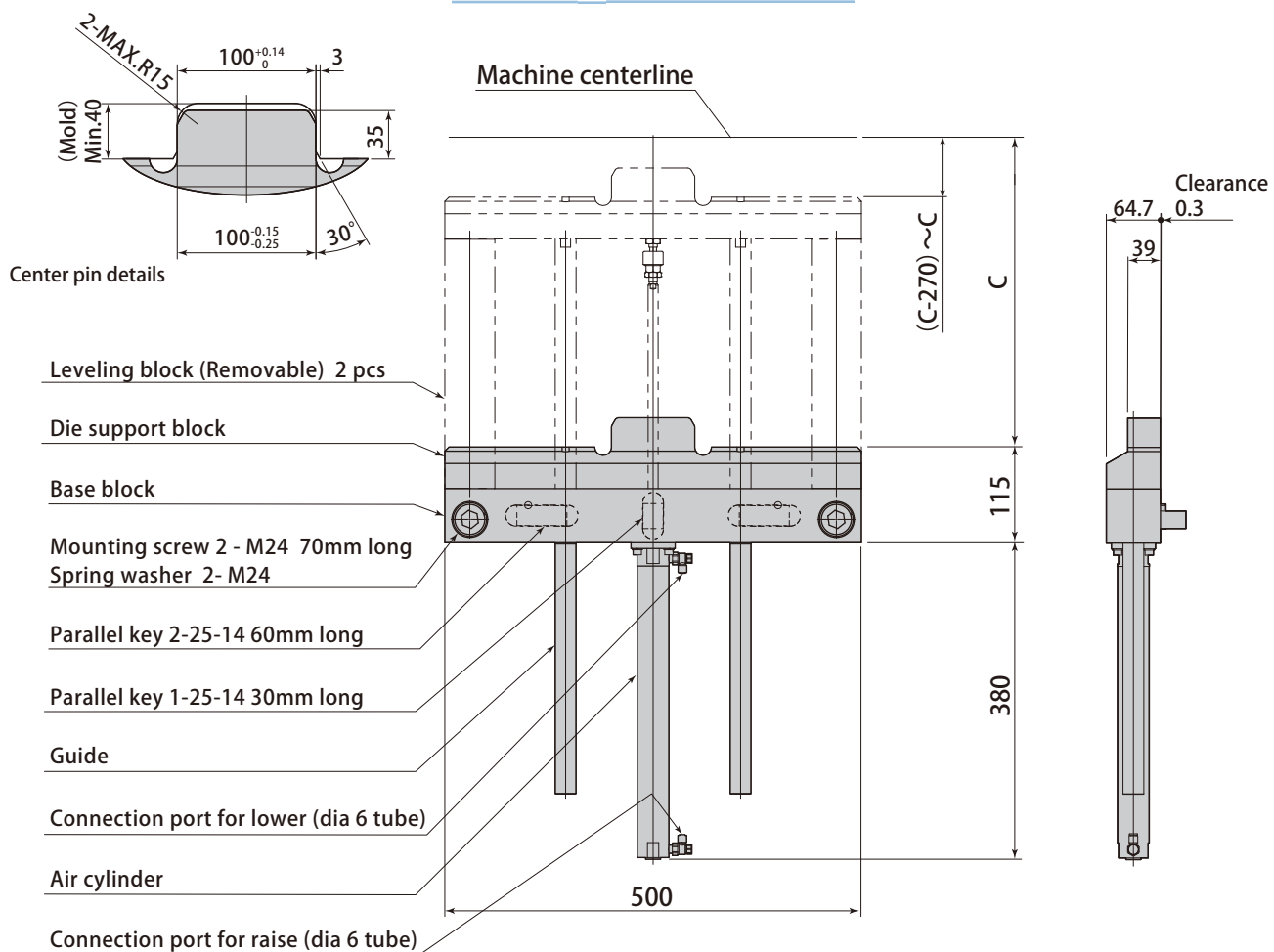

MDL10B (for movable platen)

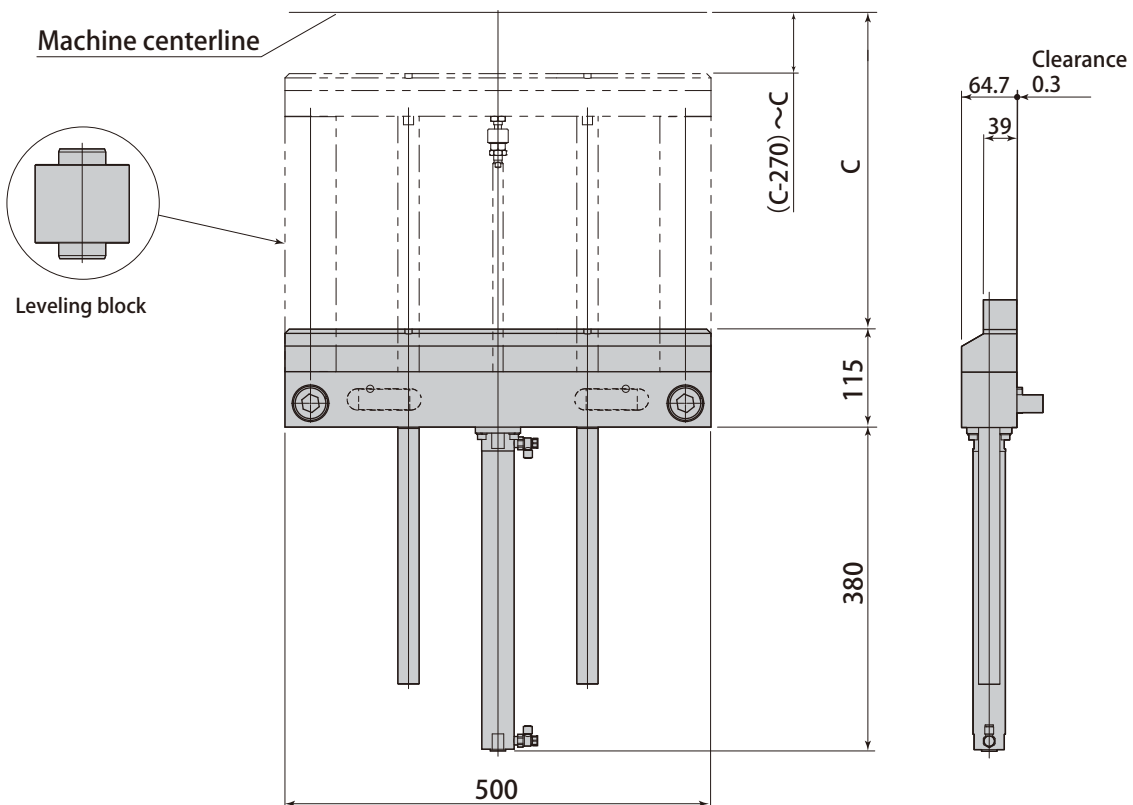

MDL15A (for fixed platen)

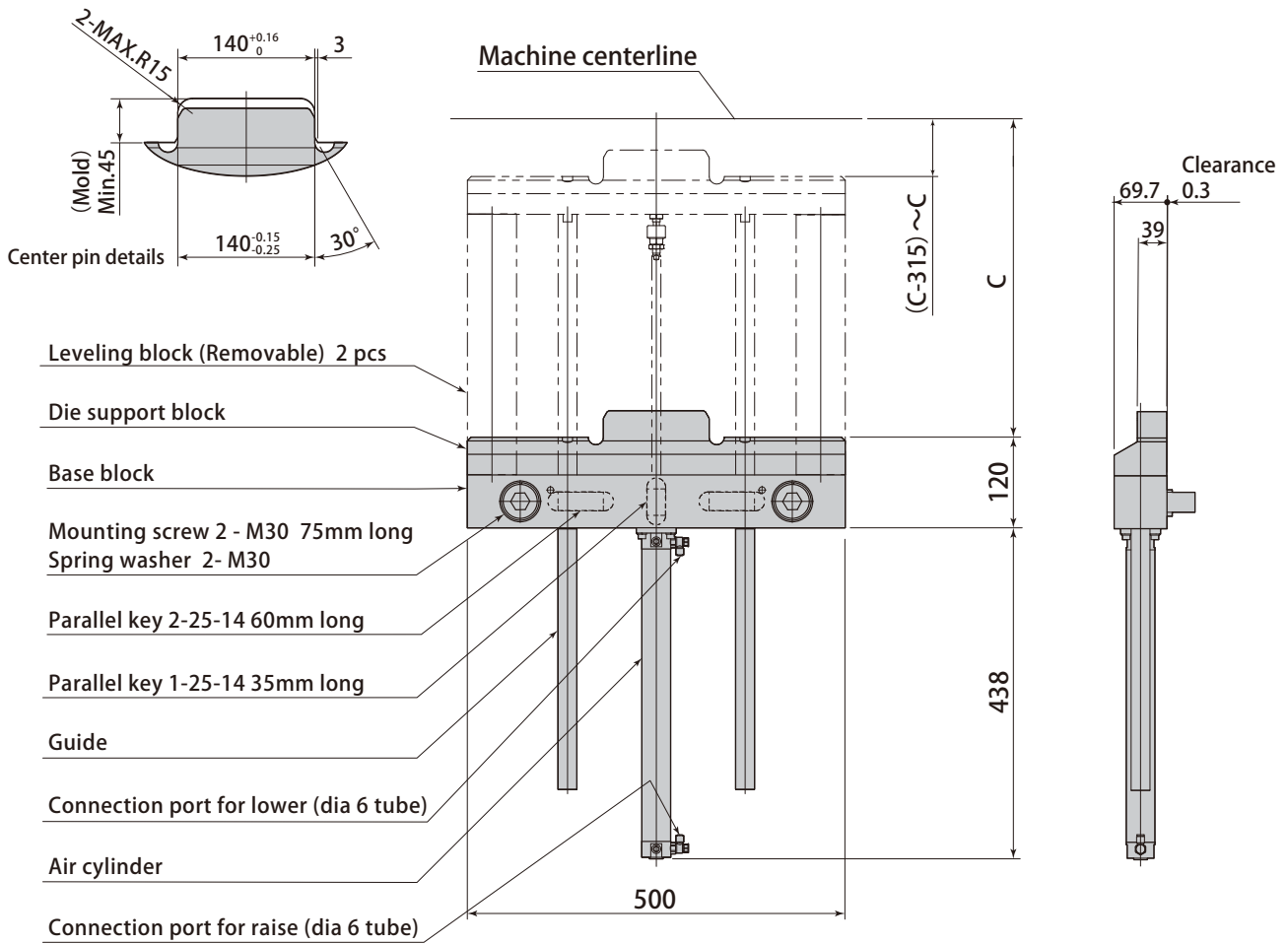

MDL15B (for movable platen)

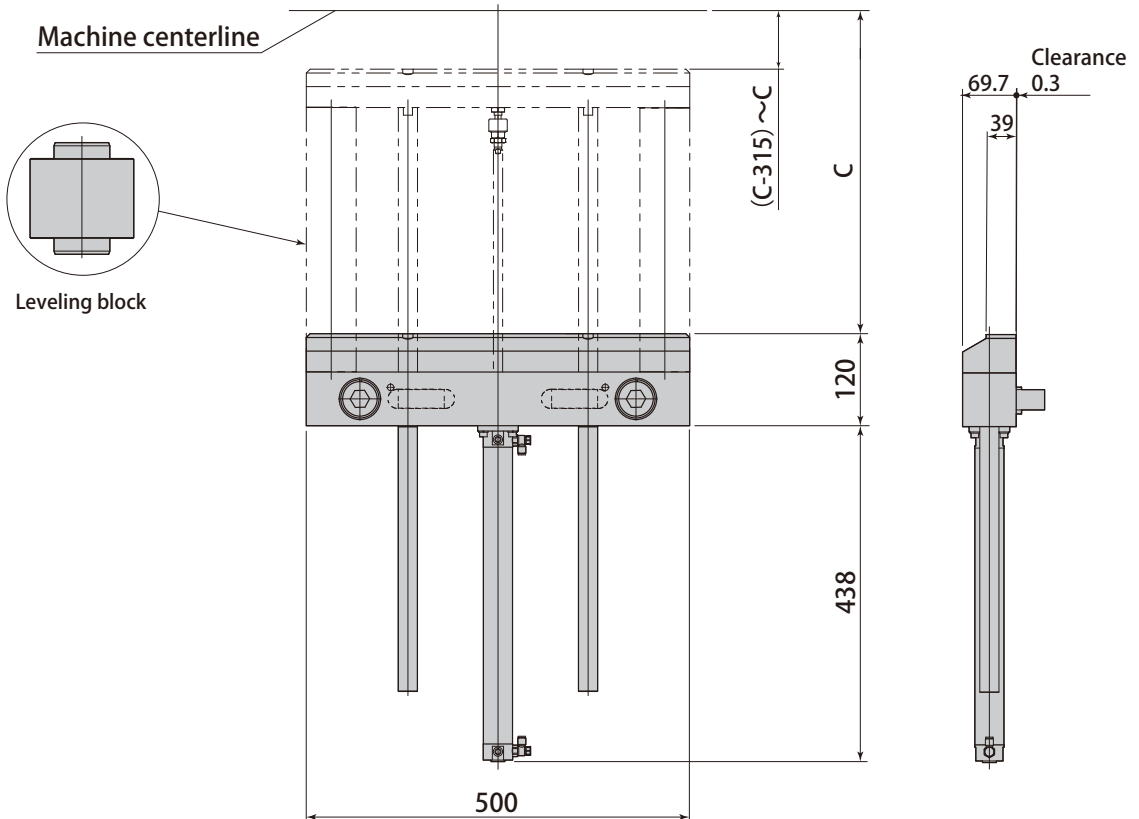

Die setter operation panel is used (in case it is controlled with hand valve)

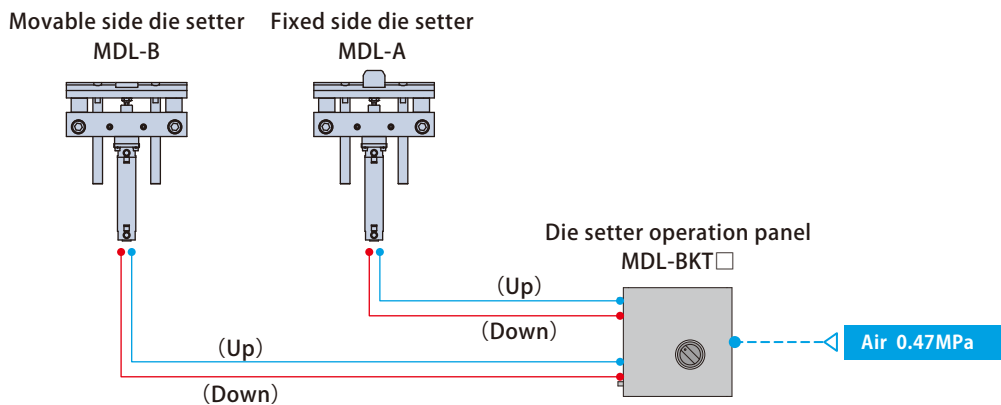

Die setter and clamp operation panel is used (in case it is incorporated in the control device)

It does not correspond to some clamps. Contact Pascal for details.

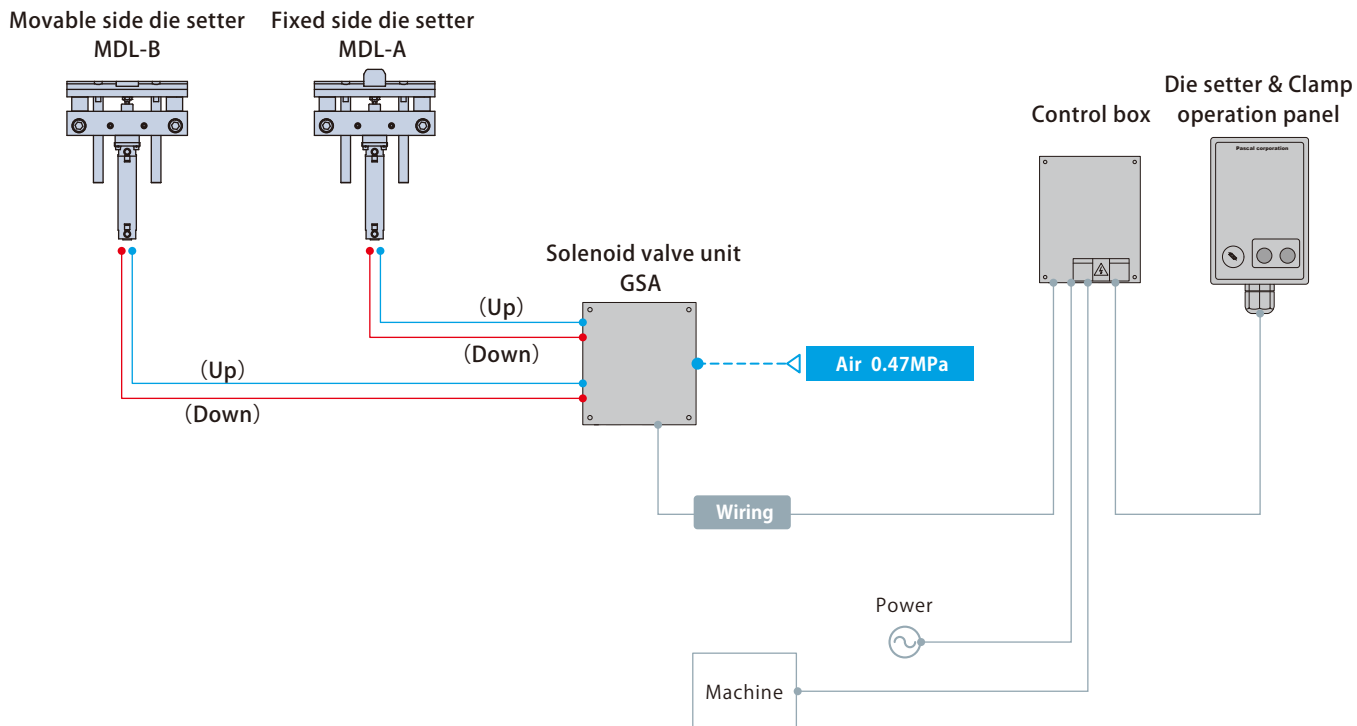



Hand valve switch

Model designation

MDL – BKT 01

..... **1** Number of circuits

01 : 1 circuit (Only fixed side)

02 : 2 circuits (Fixed side & Movable side)

MDL – BKT 01

Pneumatic circuit

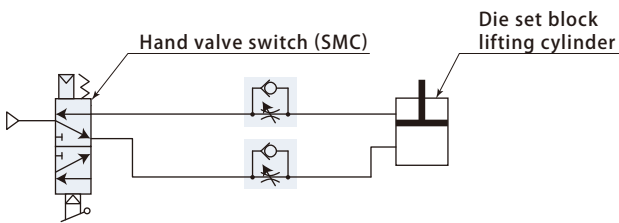

MDL – BKT 02

Pneumatic circuit

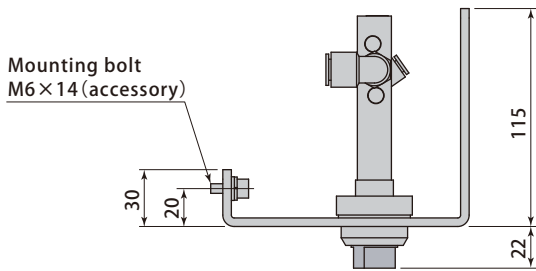
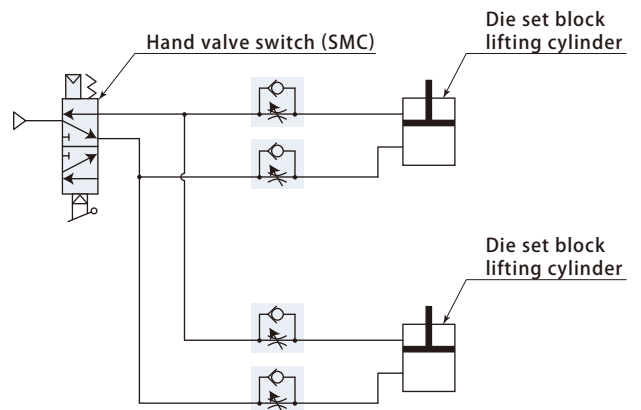

Model	MDL-BKT01	MDL-BKT02
Weight	kg	1.5

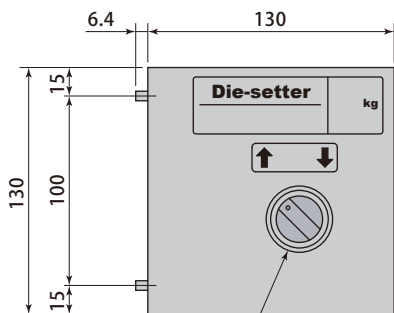

Die setter block up/down switch

MDL-BKT01

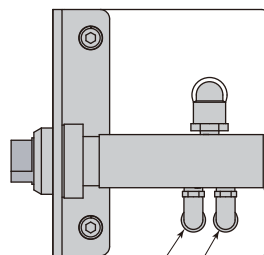

Upward port to speed controller
Downward port to speed controller

MDL-BKT02

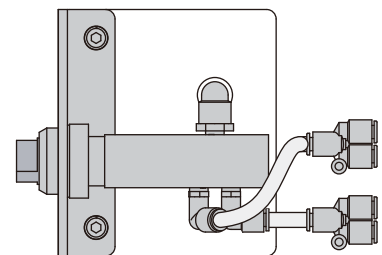

Hand valve switch (SMC)

Operational procedure

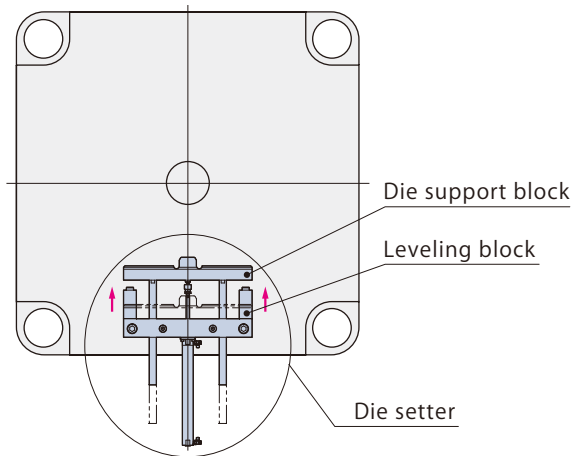

- 1 Raise the support block and place the leveling blocks on the base block.

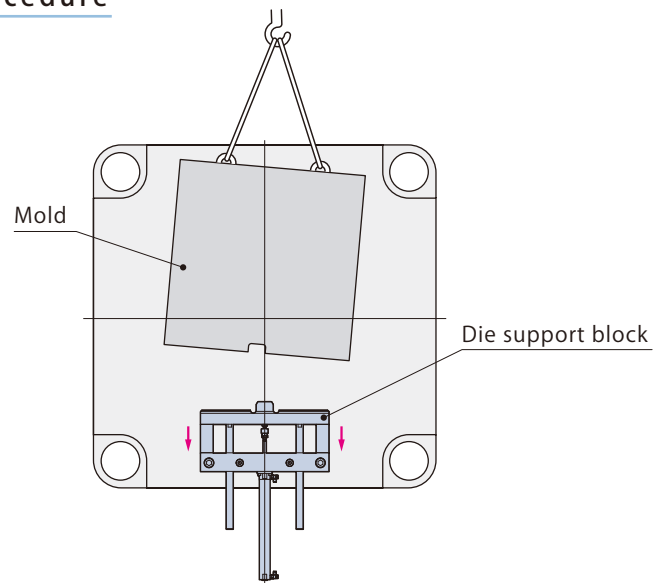

- 2 Lower the support block to accept the mold loading.

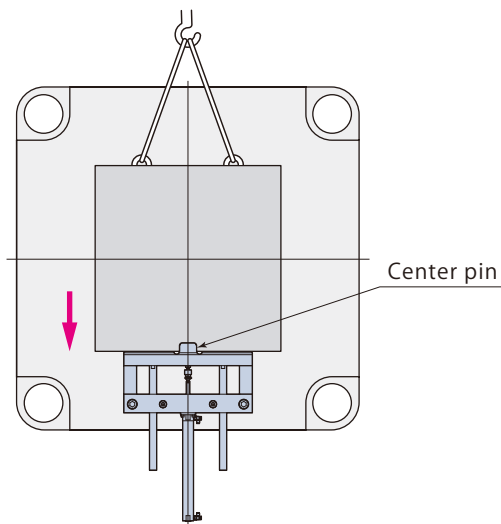

- 3 Place the mold onto the support block by dowelling the center pin to the mold cutout.

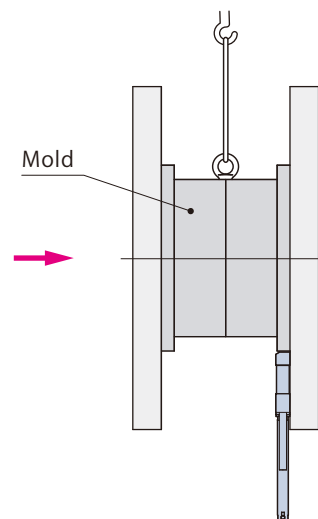

- 4 Clamp the mold by platens and die setting is completed.

Do not use the locate ring and the die setter with center pin removed at the same time simply because there is no cutout on the mold for the center pin.

✗ Danger

- The right and left(X) positioning can not be made by simply placing the mold on die setter.
- There is a risk of sudden movement of the mold when it starts skidding on the die setter.
- When the mold leans to one side, the die setter may incline due to the uneven load.

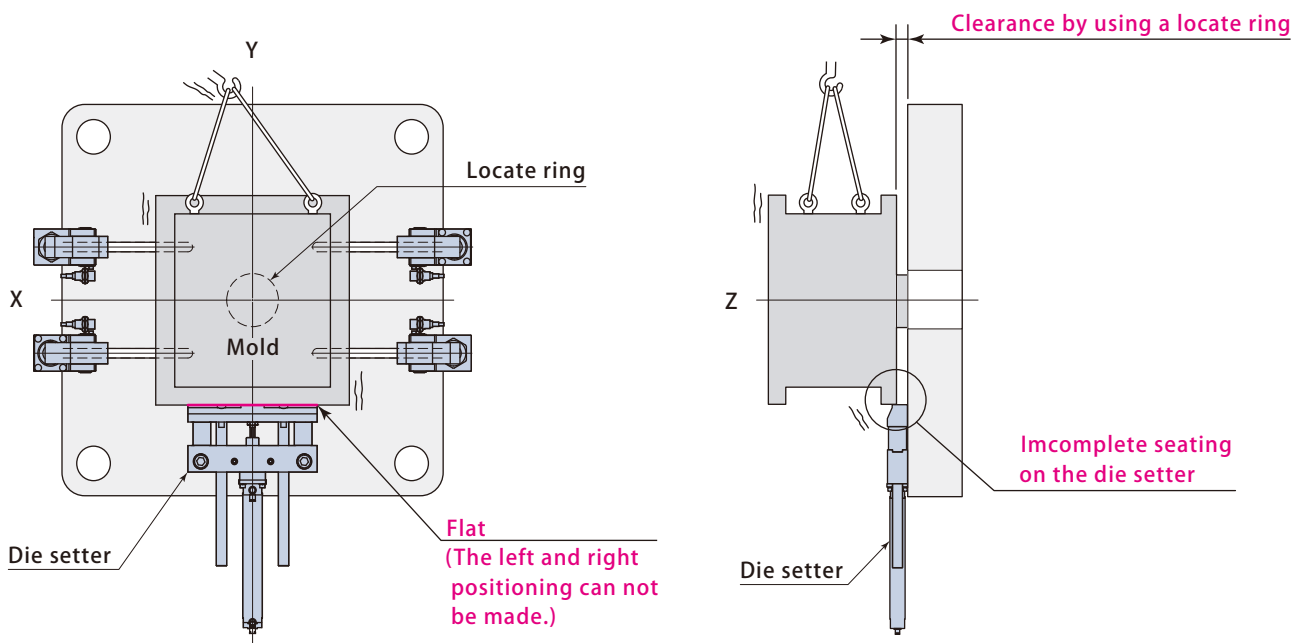

In case of using die setter for the mold with no U-cut, keep it out of the range of the mould mount area in advance not to interfere each other.

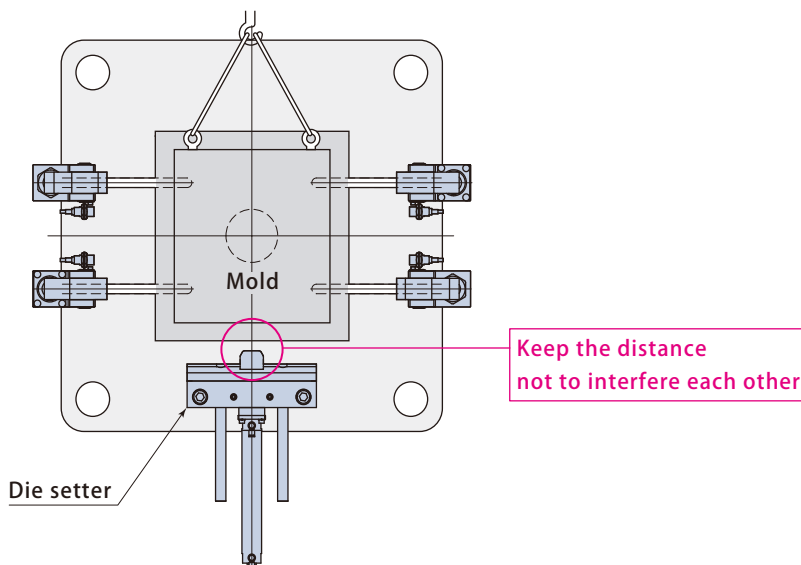

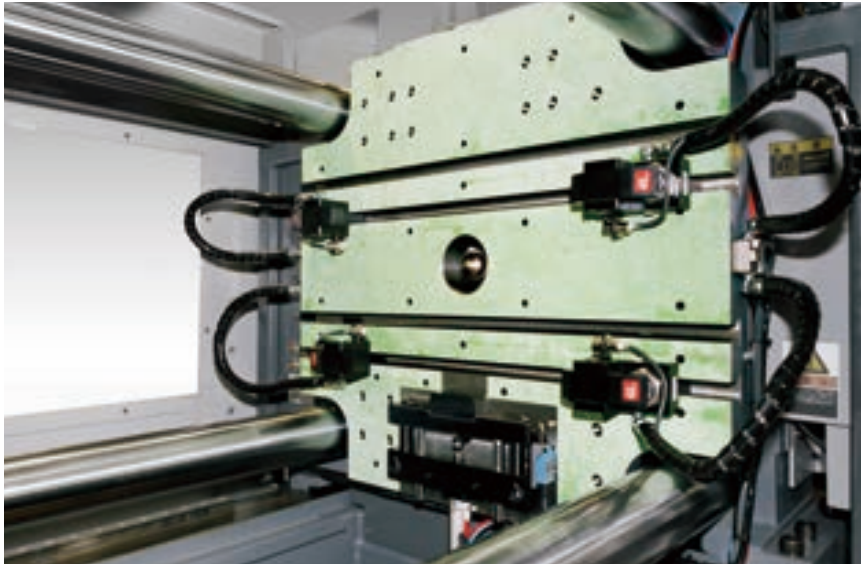

1,800kN (180ton) IMM vertical loading Die setting system & Hydraulic clamp, slidable type TYA040



6,500kN (650ton) IMM vertical loading Die setting system & Hydraulic clamp, automatic slidable type TYC100Z

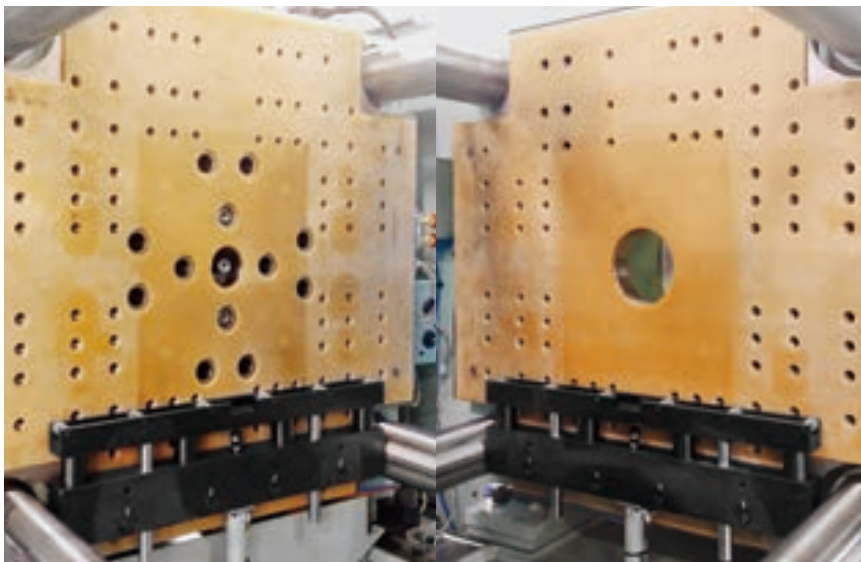

3,500kN (350ton) IMM horizontal loading Die setting roller

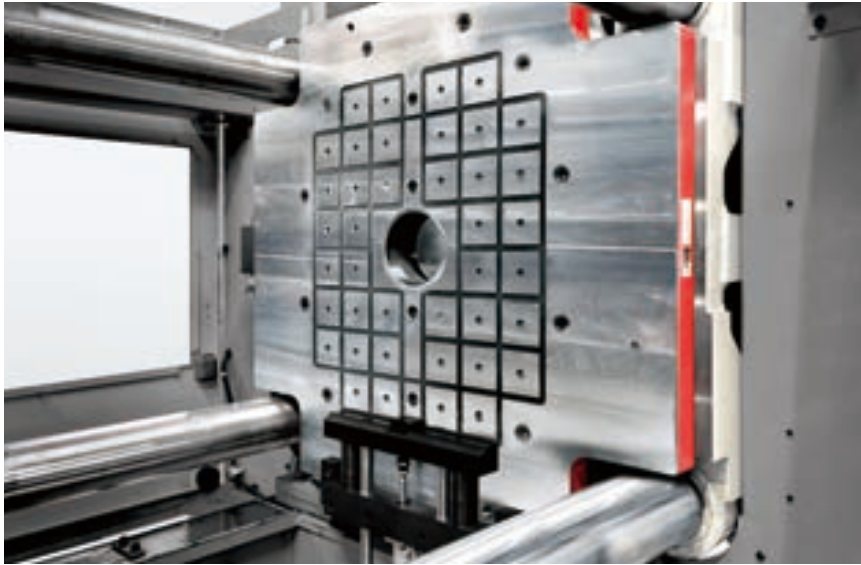

3,500kN (350ton) IMM vertical loading Die setting system & Mag clamp

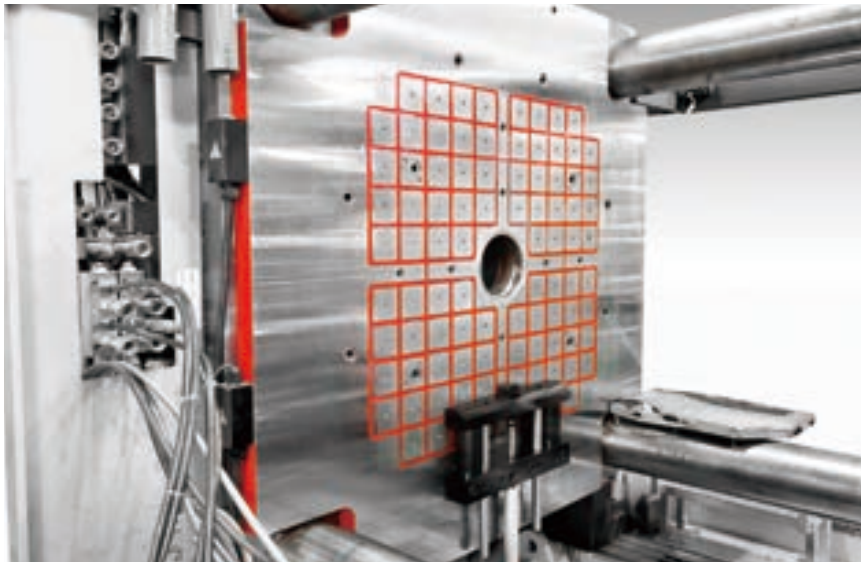

8,500kN (850ton) IMM vertical loading Die setting system & Mag clamp

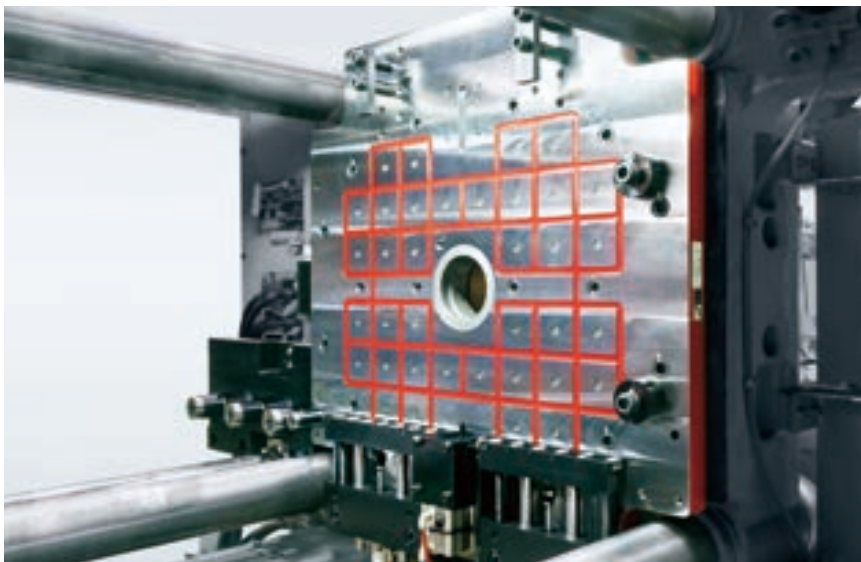

3,500kN (350ton) IMM horizontal loading Die setting roller & Mag clamp

Mold positioning for insert / hoop molding

For improvement of mold set-up time.

The use of octagonal locate ring (octagonal taper cone) provides easy positioning, eliminating need for retraining of robot.

Mold side

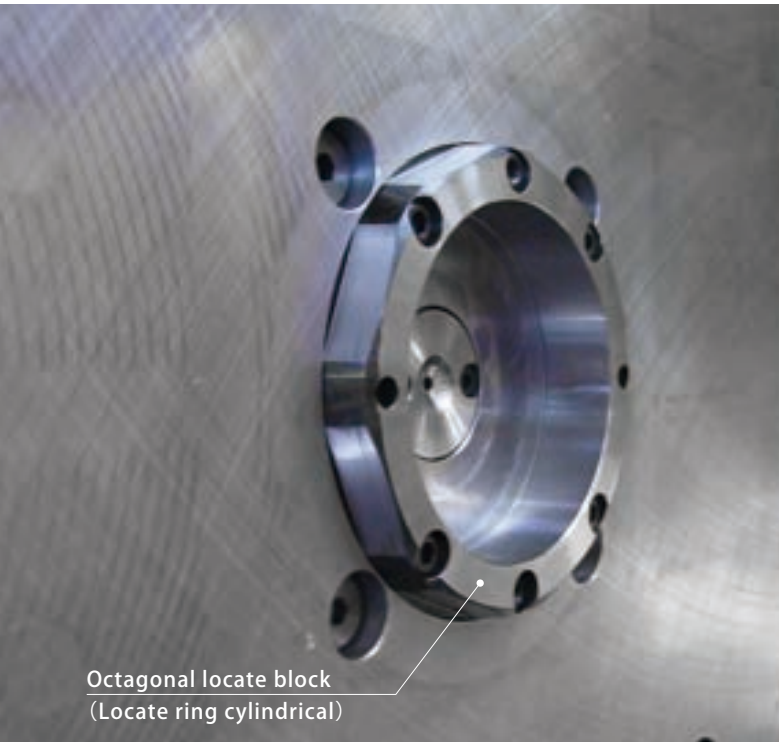

Octagonal locate block
(Locate ring cylindrical)

Fixed platen side

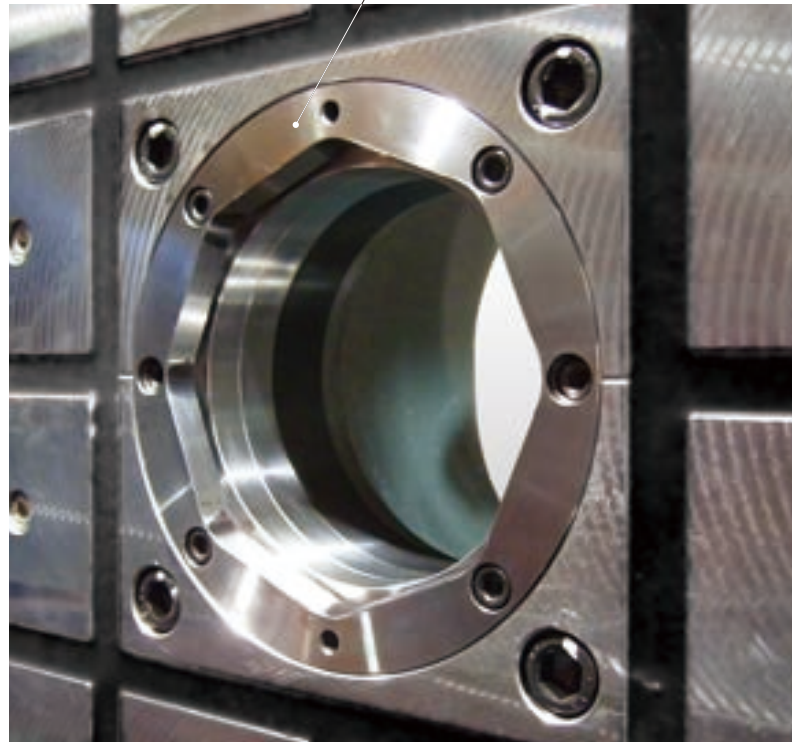

Octagonal locate ring
(Base)

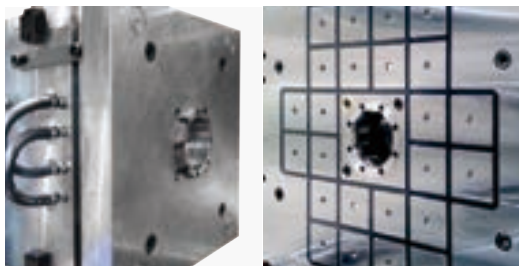

1,800kN (180ton) IMM vertical loading
Octagonal locate ring & Mag clamp



500kN (50ton) Vertical IMM
Octagonal locate ring (positioning for upper mold)
& Rollers

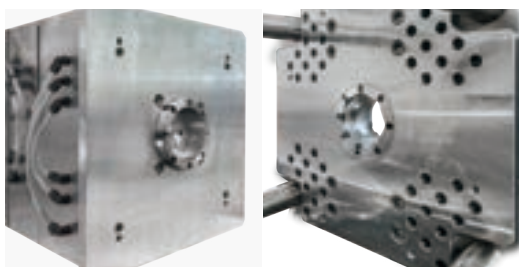

500kN (50ton) IMM vertical loading
Octagonal locate ring

High rigidity can be obtained by receiving mold weight on multiple faces.

Taper allows easy mold setting.

Restrained 8-faces can provide easy centering.

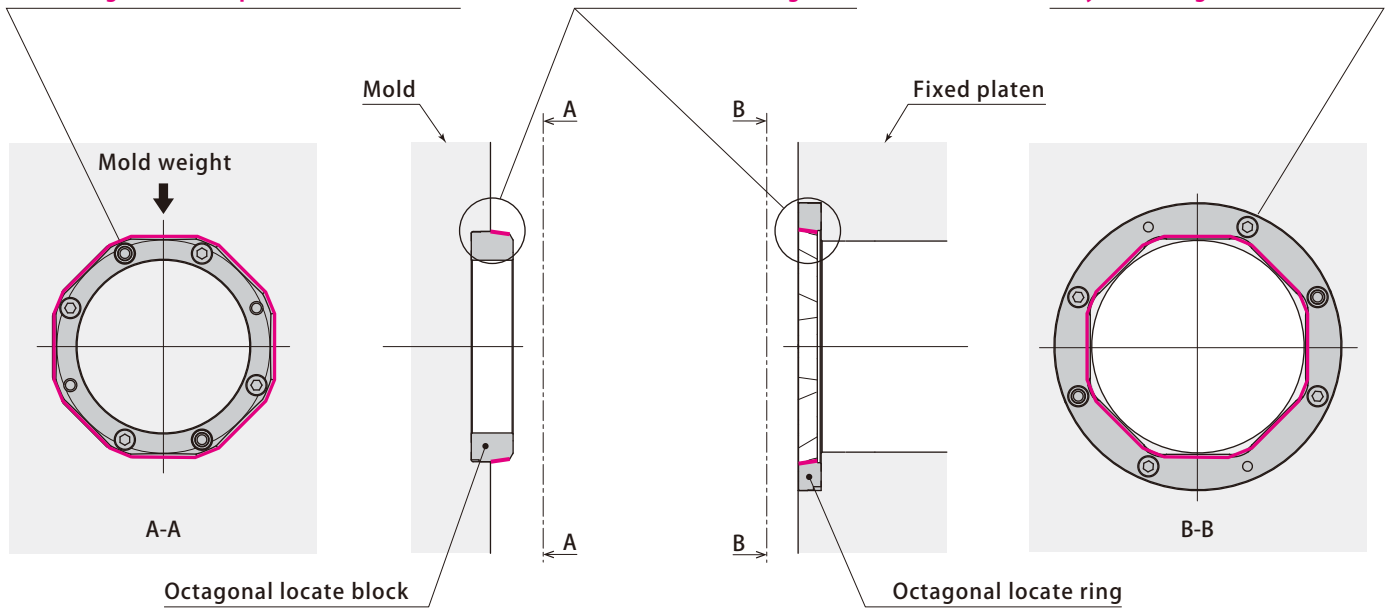

Octagonal locate block



Octagonal locate ring

Model		MCL070	MCL100	MCL120
Ring size	mm	70 equivalent	100 equivalent	120 equivalent
Applied IMM	Clamping force	Up to 2000 (200)		
	Loading direction	Vertical loading, Vertical IMM		

Mag clamp & Octagonal locate ring
(When the ring mounted in magnet plate)

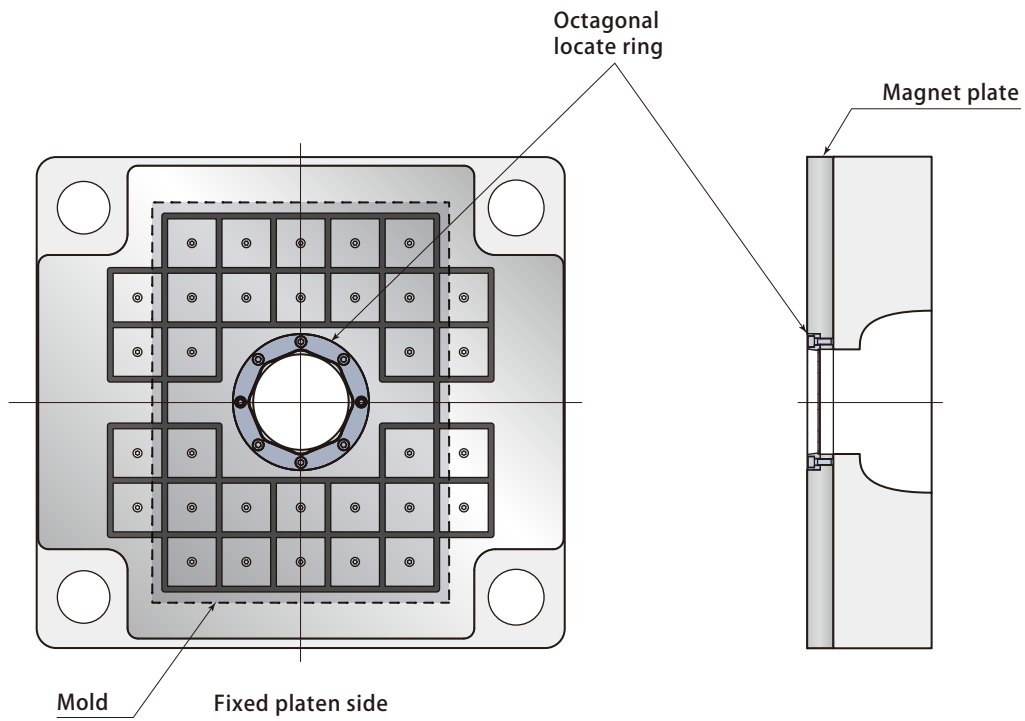

Adaptor plate & Octagonal locate ring

(When using a automatic clamp or a manual clamp)

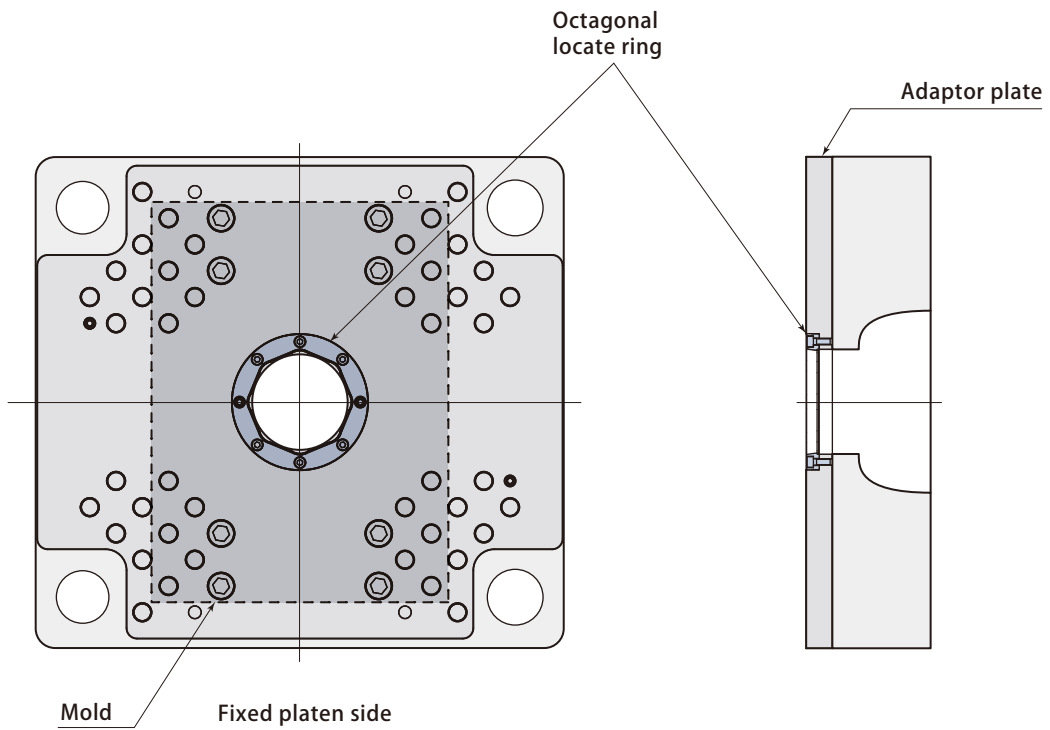

- Positioning can easily be completed by sliding the mold on rollers checking visually the alignment of mounting the octagonal locate block and the octagonal locate ring. (On the basis of upper side)
- It can eliminate positioning the mold by pushing to a parallel pin as positioning block.

Mag clamp & Octagonal locate ring & Rollers

(When the ring mounted in magnet plate)

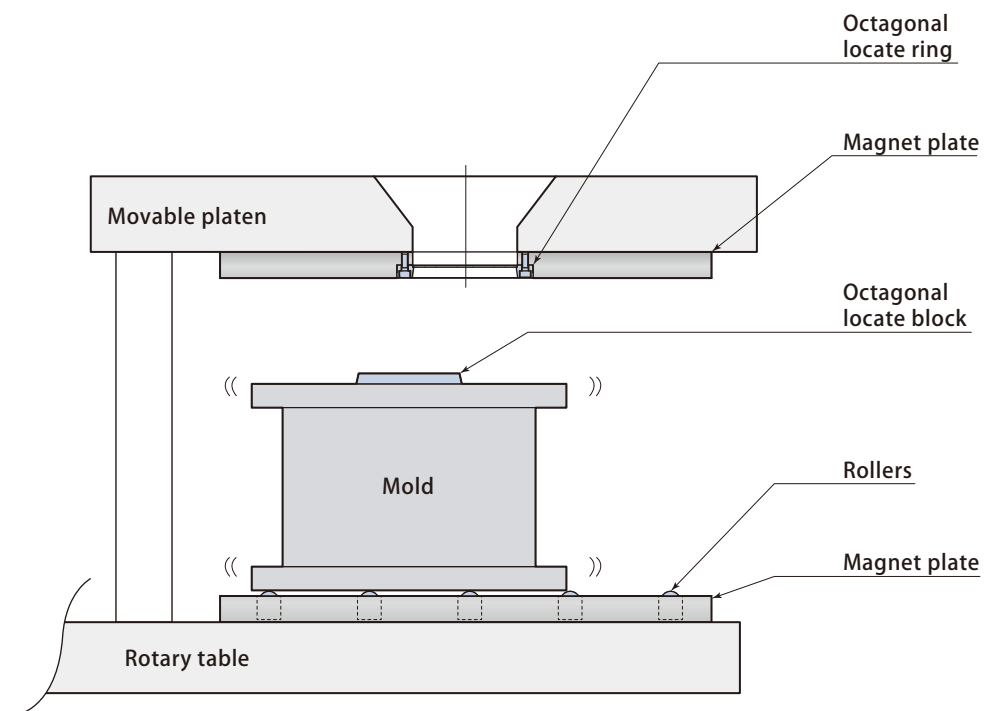

Octagonal locate ring & Rollers

(When using a automatic clamp or a manual clamp)

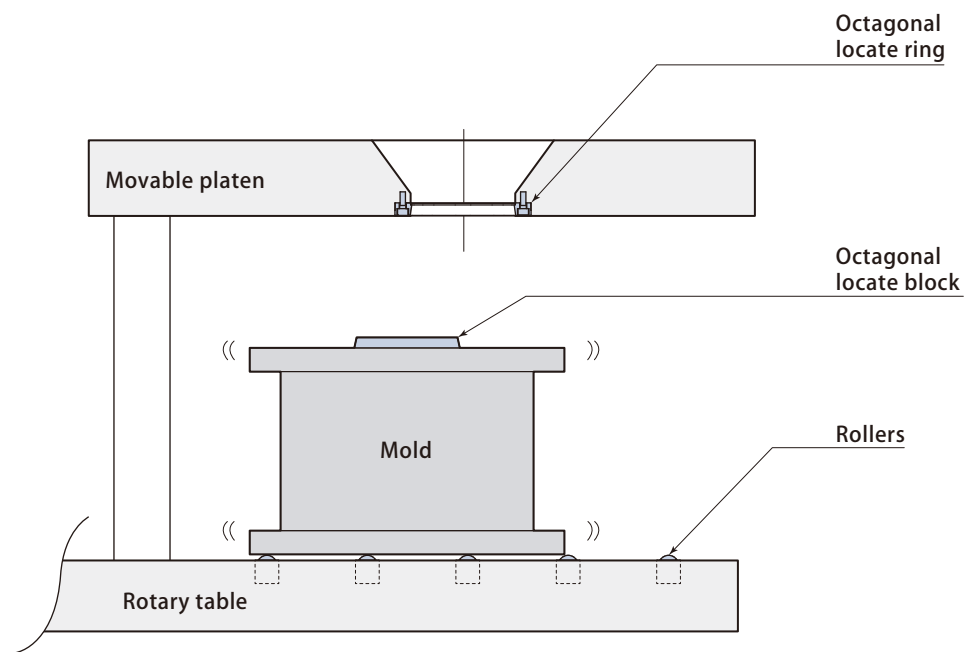

Dimensions

Octagonal locate block
(MCL070P)

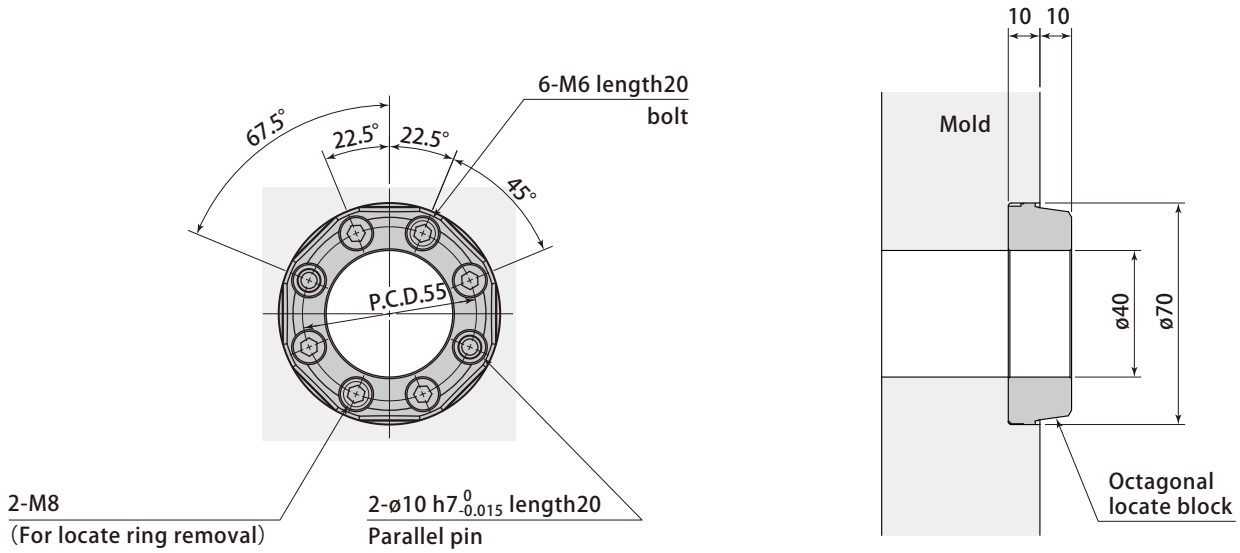

Octagonal locate ring
(MCL070S)

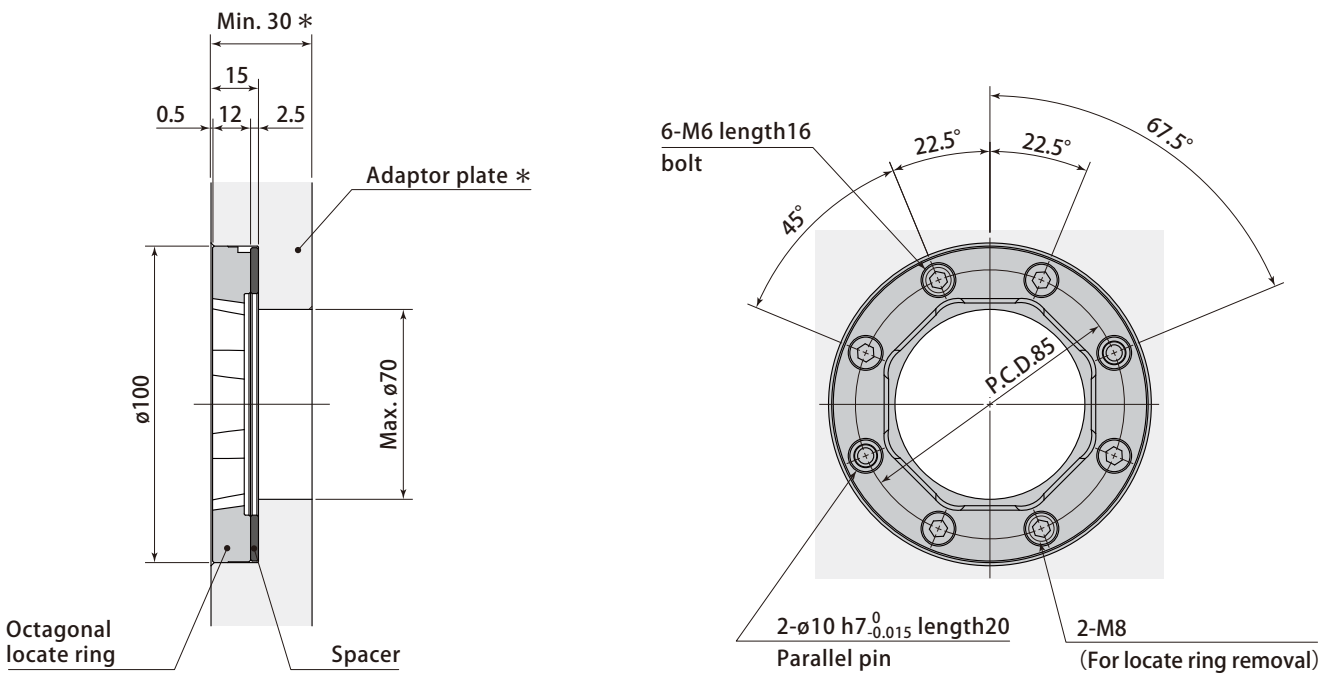

The adaptor plate thickness should be over 30mm when it is mounted on the plate.

Mounting details

Octagonal locate block
(MCL070P)

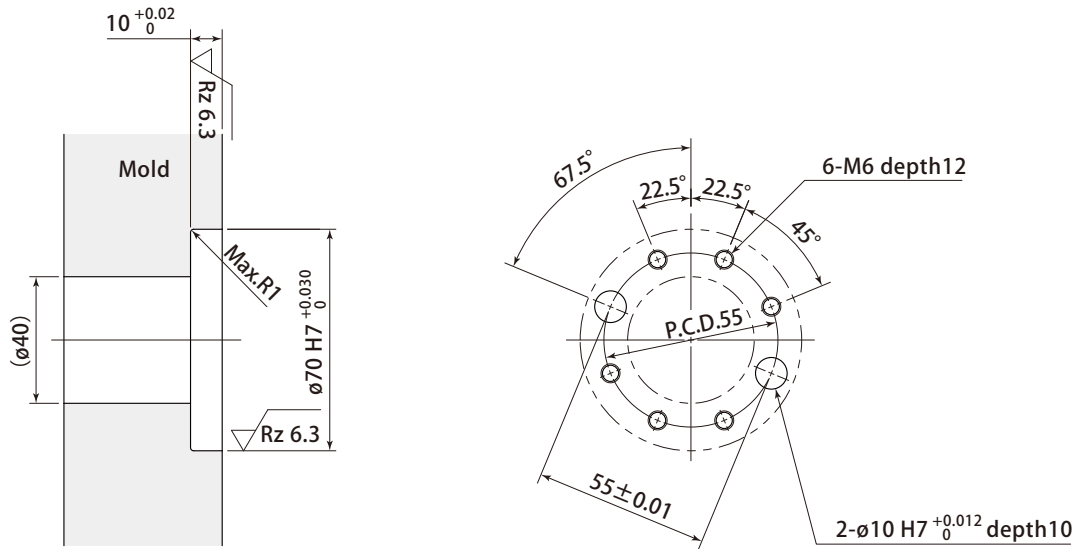

Octagonal locate ring
(MCL070S)

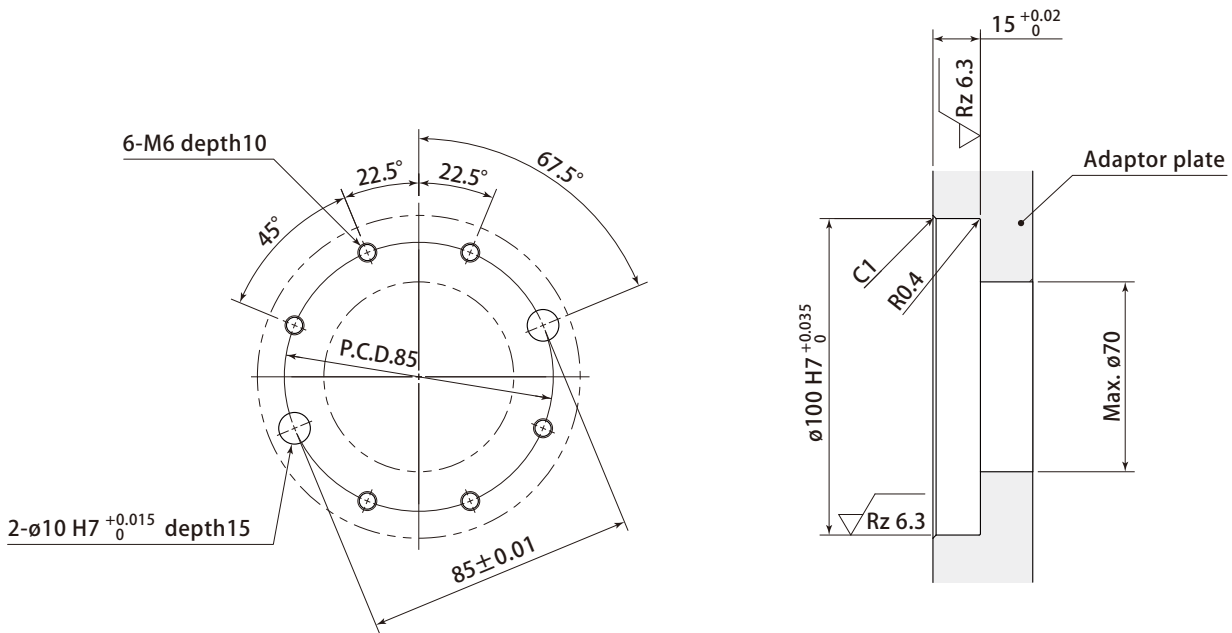

Dimensions

Octagonal locate block
(MCL100P)

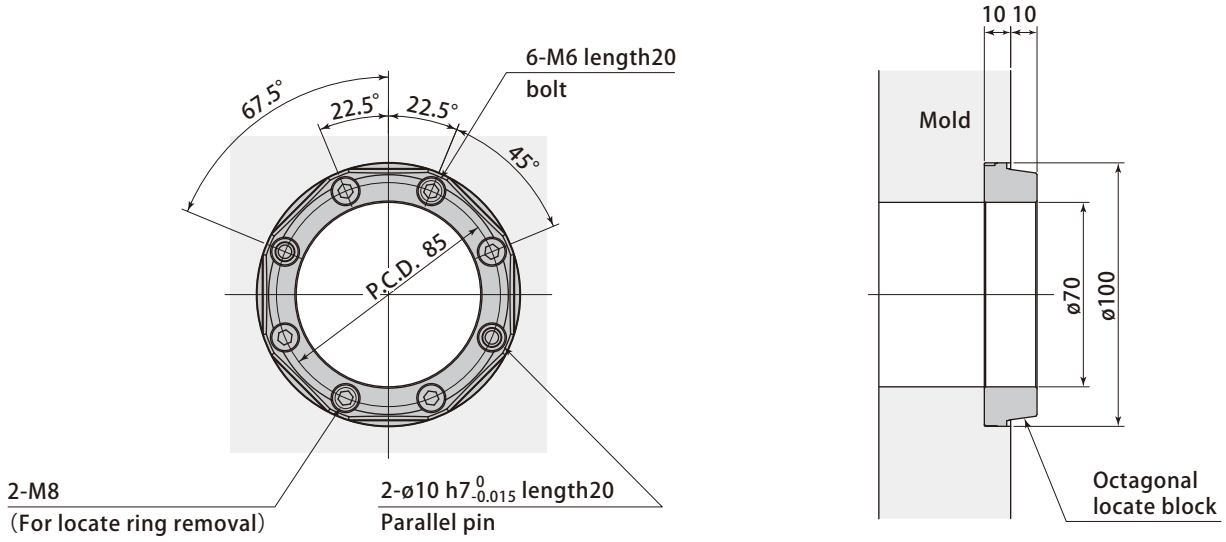

Octagonal locate ring
(MCL100S)

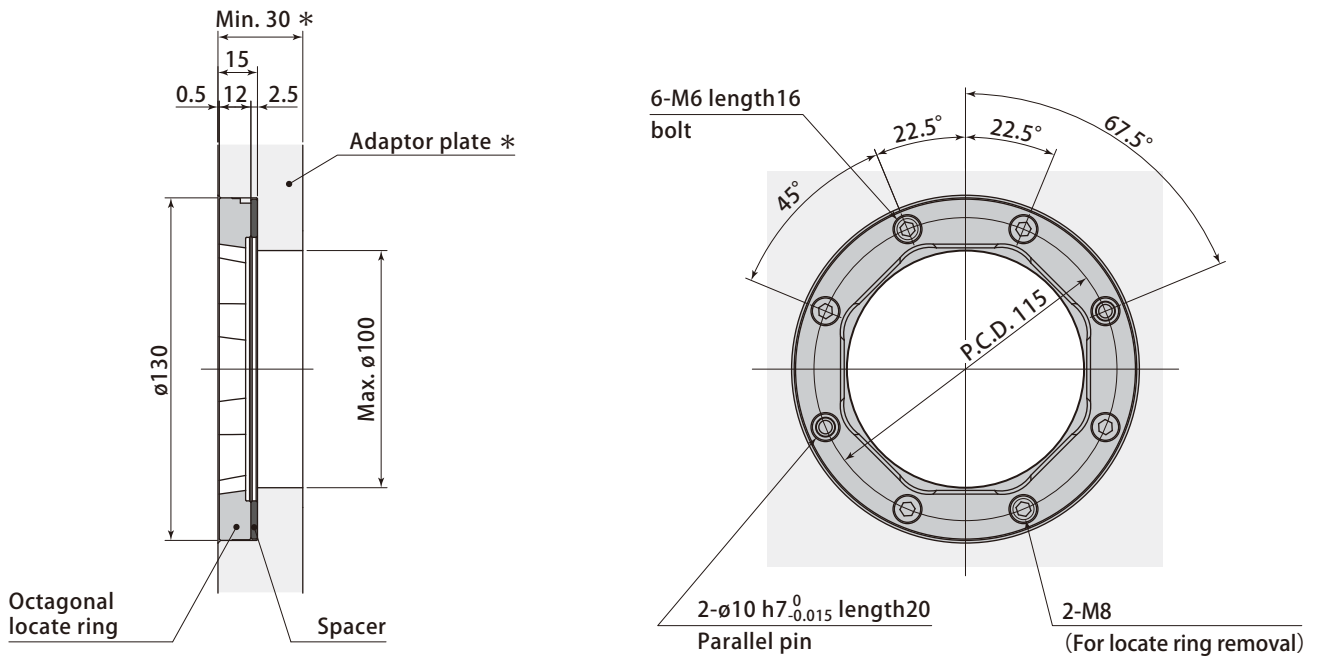

The adaptor plate thickness should be over 30mm when it is mounted on the plate.

Mounting details

Octagonal locate block
(MCL100P)

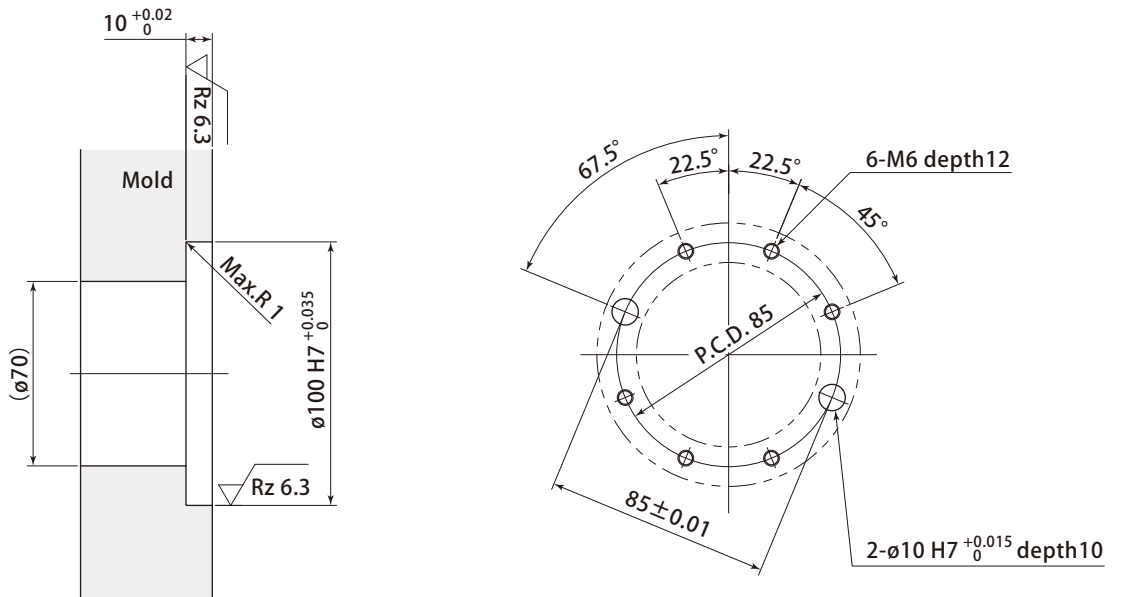

Octagonal locate ring
(MCL100S)

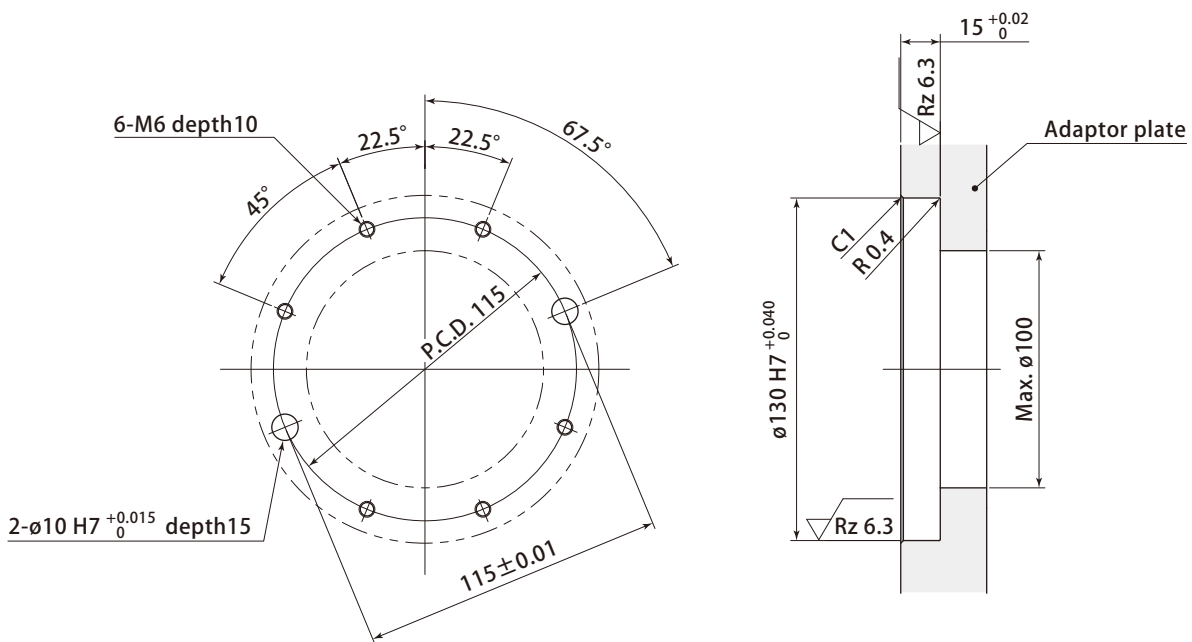

Dimensions

Octagonal locate block
(MCL120P)

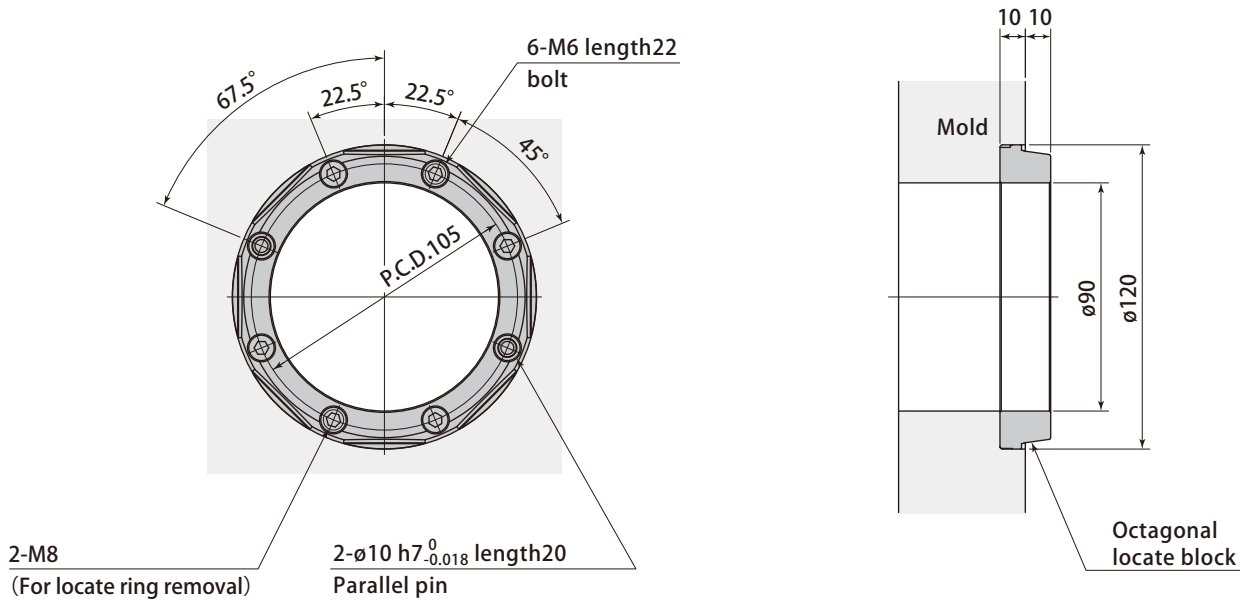

Octagonal locate ring
(MCL120S)

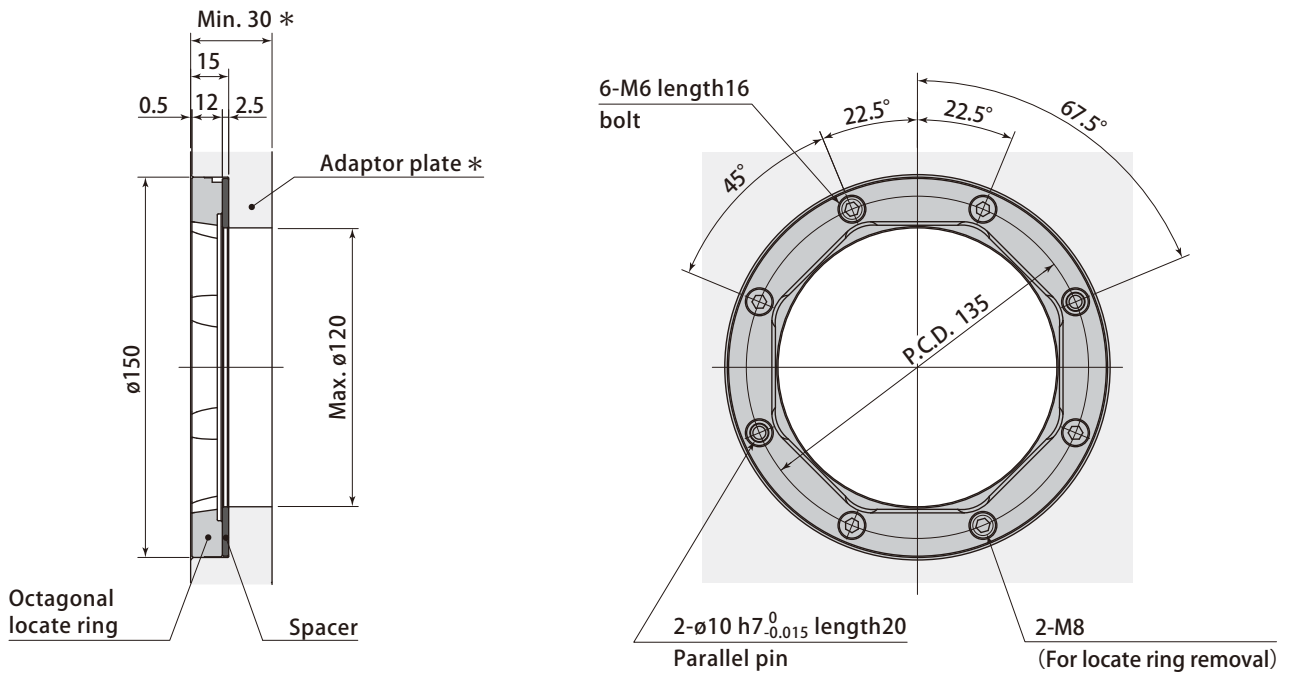

The adaptor plate thickness should be over 30mm when it is mounted on the plate.

Mounting details

Octagonal locate block
(MCL120P)

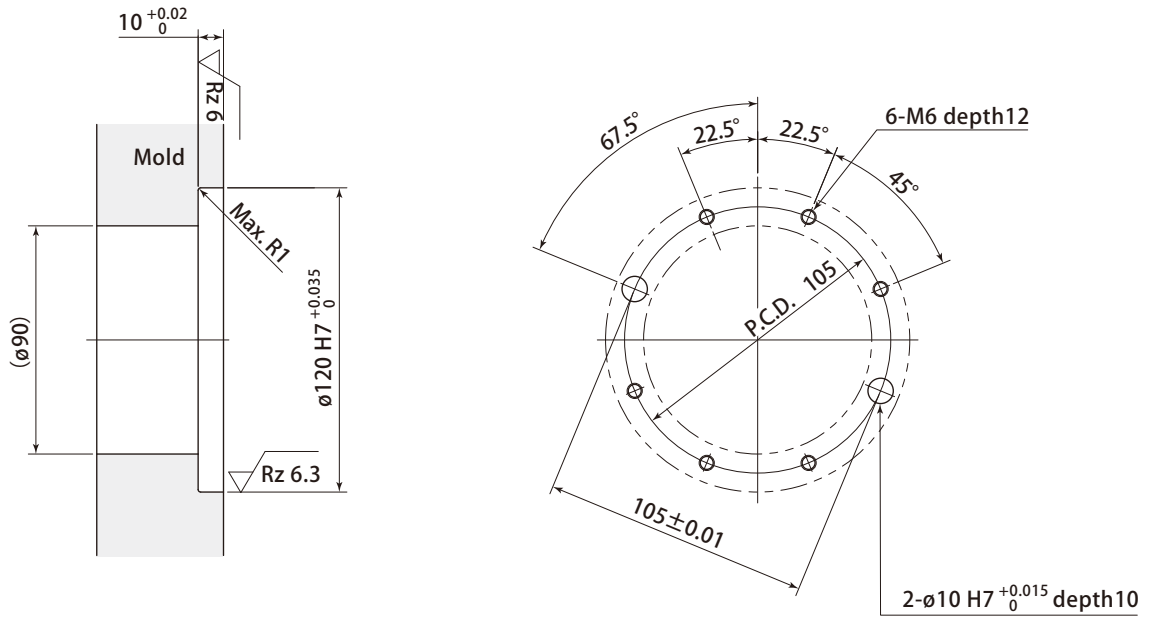

Octagonal locate ring
(MCL120S)

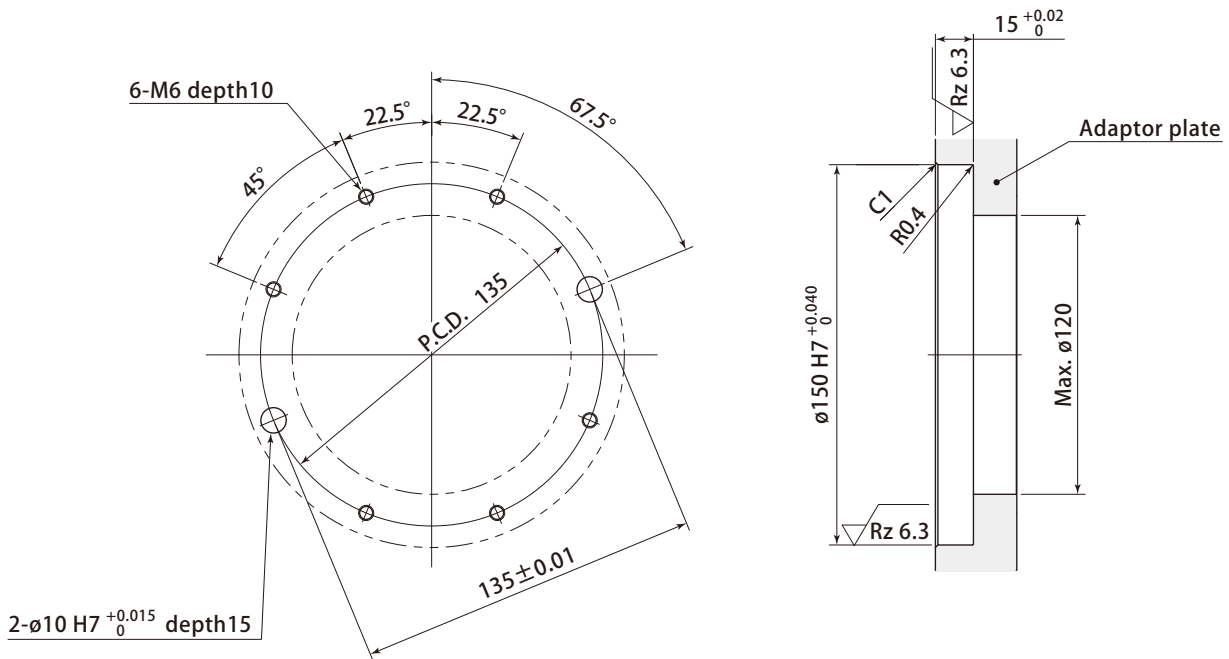

Pascal Easy ejector rod makes an ejector rod changing dramatically easier.

It is a newly designed ejector rod with strong magnets on the joint surface of the fixed/removable rods, which plugs in/out by one-touch operation.

30,000
pieces
have been
sold

5,500kN (550ton) IMM
Changing ejector rod
3min13sec to 30sec



Model designation

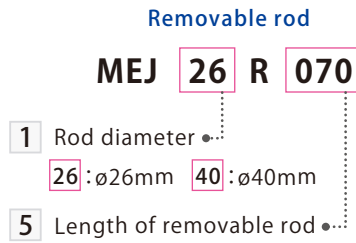
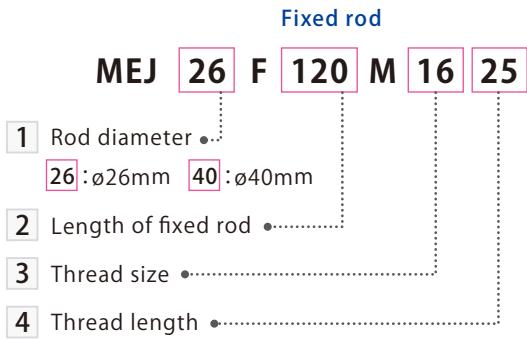

2 3 4 5 Refer to page → 120

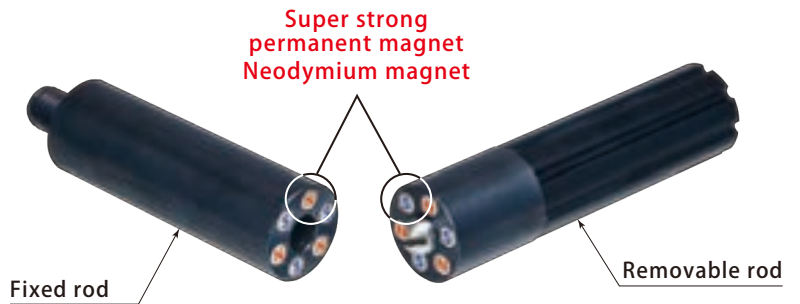
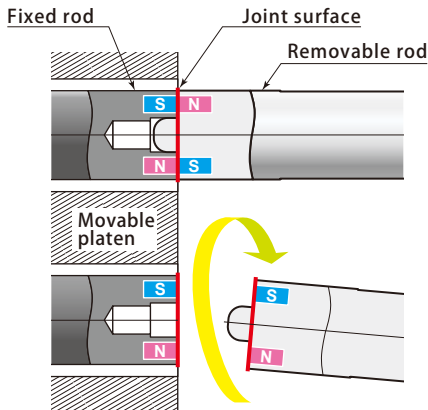

Model		MEJ26	MEJ40
Rod diameter	mm	ø26	ø40
Applied IMM	Clamping force	kN (ton)	13000 (1300) or less
	Loading direction		Vertical loading, Horizontal loading

Conventional ejector rod

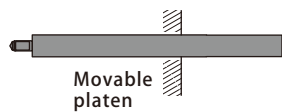

Easy ejector rod

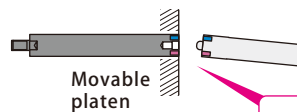

Separated into fixed and removable rod

If using conventional ejector rod,

Heavy ejector rod.

Ex. 350ton class : approx. 3kg
1,000ton class : approx.12kg

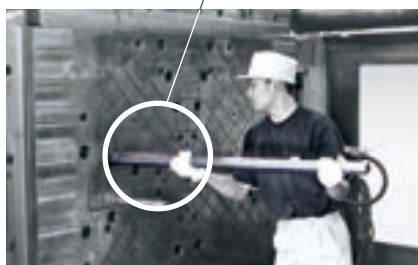

Poor workability and tool dropped easily in machine.



Long thread takes time to screw/unscrew.

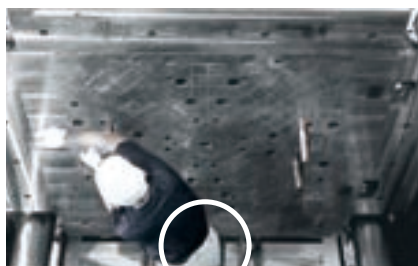

Installation in a limited space with bad footing.

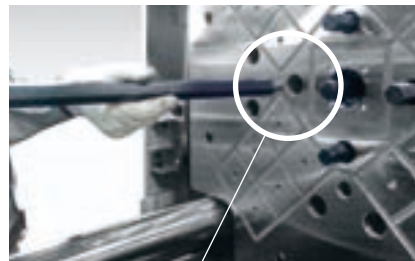

Hard to check the thread and screw hole when screwing.



If using the Easy ejector rod,

Quick installation



Quick de-installation
(Separated into fixed and removable rod)

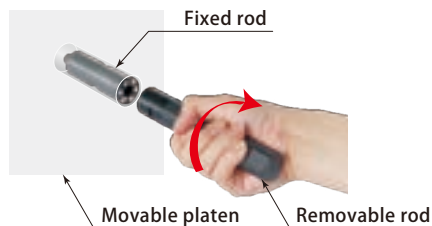

- Only 300g & 1/10-lightweight !!
* 350ton-class
- No tools required
- Avoid dangerous work
- Simply detach removable rods

Easy ejector rod installation example

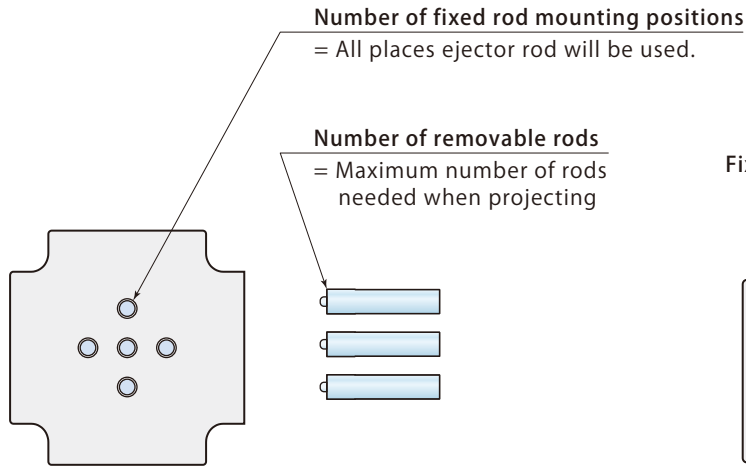

	Rod diameter	Pieces
Fixed rod	ø26	5
Removable rod		3
Jig rod		1

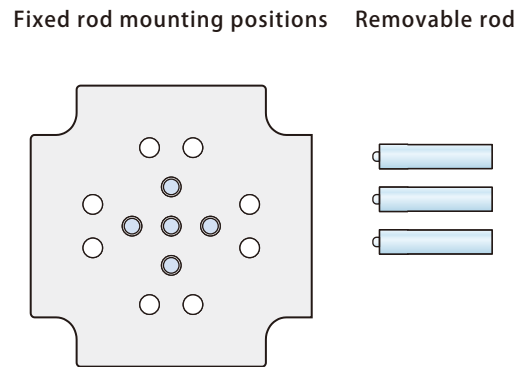

	Rod diameter	Pieces
Fixed rod	ø26	5
Removable rod		3
Jig rod		1

Fixed rod mounting positions **Removable rod**

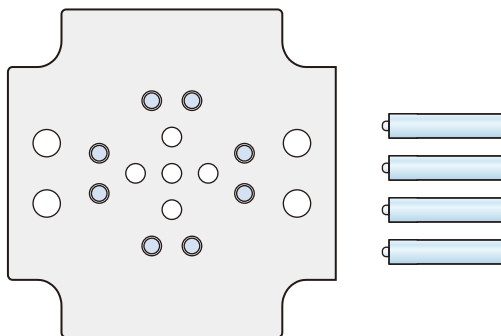

	Rod diameter	Pieces
Fixed rod	ø26	8
Removable rod		4
Jig rod		1

Fixed rod mounting positions **Removable rod**

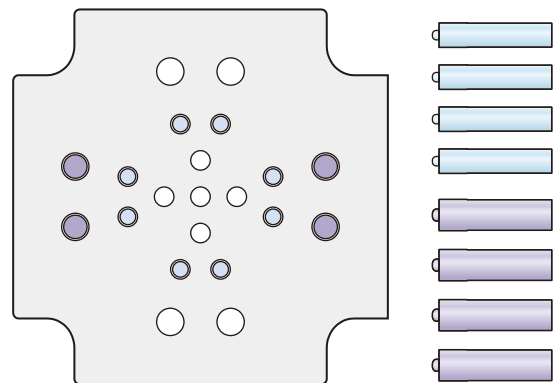

	Rod diameter	Pieces
Fixed rod	ø26	8
Removable rod		4
Jig rod		1
Fixed rod	ø40	4
Removable rod		4
Jig rod		1

Rod dimensions

An existing ejector rod can be used with Easy ejector rod.
Then Easy ejector rod can be used immediately.

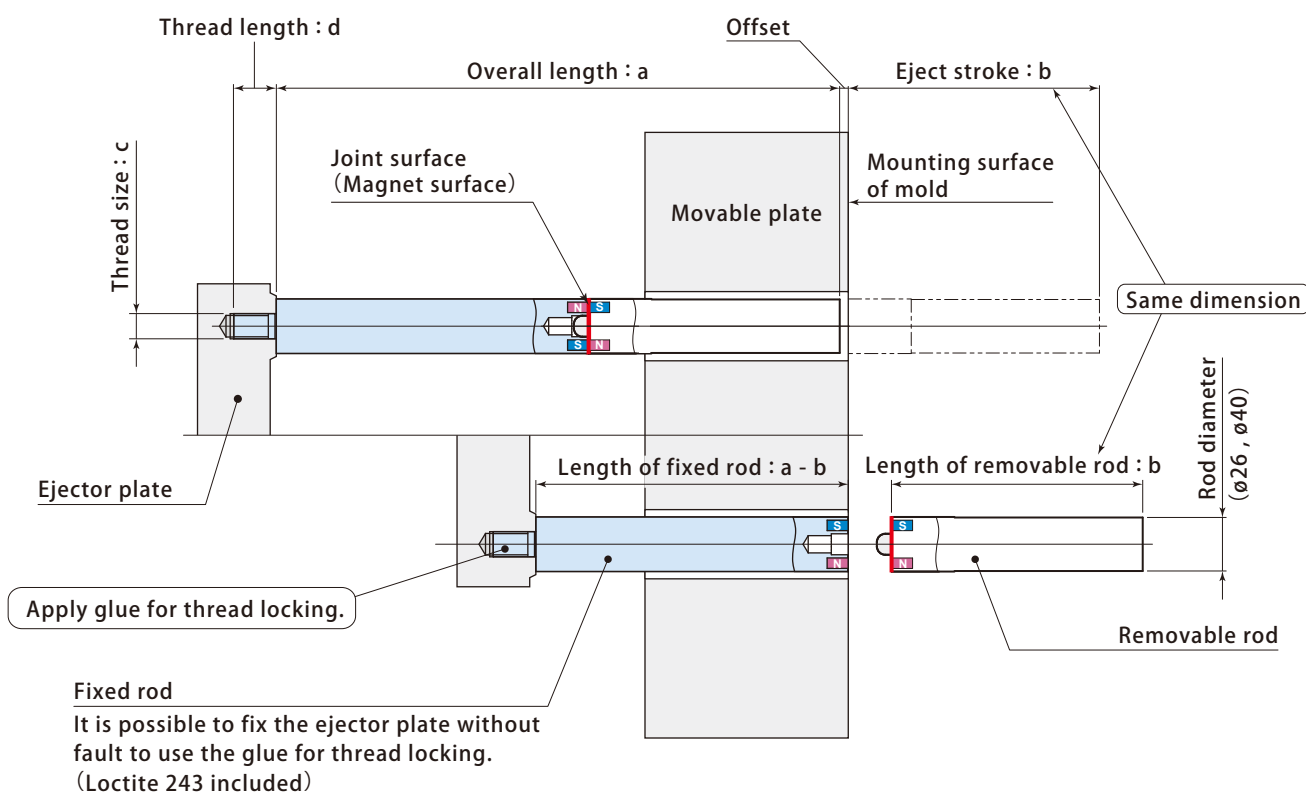

- Upon confirming machine model or above dimensions $\langle a, b, c, d \rangle$, Pascal will calculate rod dimensions.
- If special specification is required, please contact Pascal.

Fixed rod

Model	MEJ26F	MEJ40F
Rod diameter mm	ø26	ø40
Length of fixed rod : a - b mm	40 and over	

Removable rod

Model	MEJ26R	MEJ40R
Rod diameter mm	ø26	ø40
Eject stroke : b (Length of removable rod) mm	70 ~ 250	70 ~ 300



Fixed rod Jig rod

Model	MEJ26T	MEJ40T
Rod diameter mm	ø26	ø40

- Mounting jig must be purchased as a set.
Jig rod can be used repeatedly.

1,000kN (100ton) IMM
1min08sec to 6sec

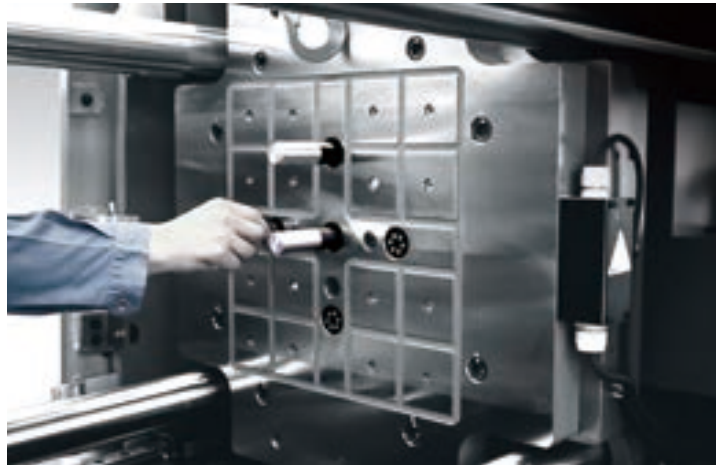

5,500kN (550ton) IMM
5min30sec to 20sec



14,000kN (1,400ton) IMM
3min40sec to 20sec



How to mount fixed rod

- 1 Screw jig rod ⑥ to fixed rod ④ and tighten it up with cap screw.

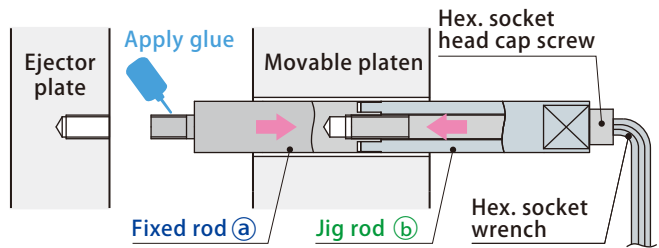

- 2 Screw the rod ④ + ⑥ to the ejector plate then tighten it up by a wrench.

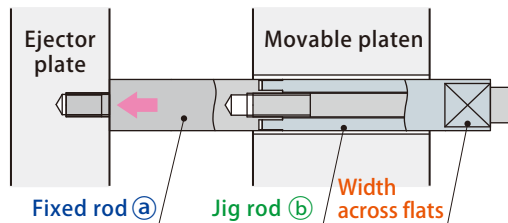

- 3 Remove jig rod ⑥ from fixed rod ④ by loosening the cap screw.

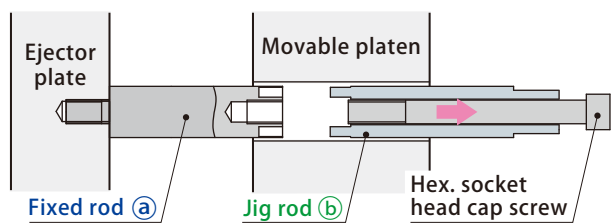

- 4 Screw fixed rod ③ to fixed rod ④ then tighten it by Hex. socket wrench.

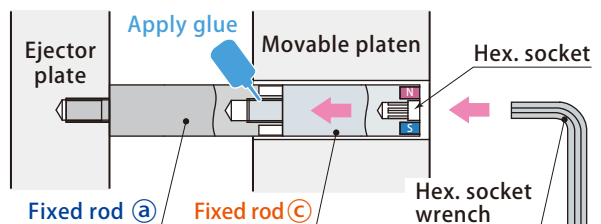

Applied for large sized IMM with the ejector stroke more than 300mm.

The ejector rod can be installed and removed by one-touch operation with the ball lock structure.

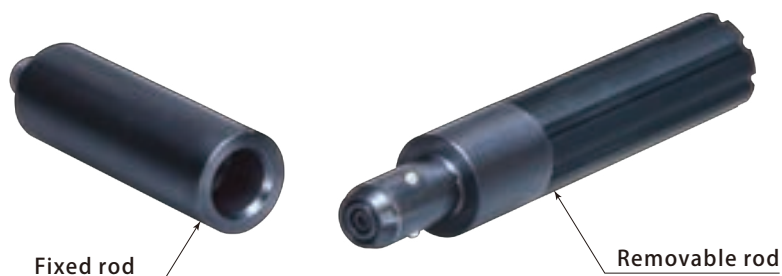

Model designation

Fixed rod

MEL **26** F **120** M **16** **25**

- 1 Rod diameter •
26 : $\phi 26\text{mm}$ 40 : $\phi 40\text{mm}$
- 2 Length of fixed rod •
- 3 Thread size •
- 4 Thread length •

Removable rod

MEL **26** R **070**

- 1 Rod diameter •
26 : $\phi 26\text{mm}$ 40 : $\phi 40\text{mm}$
- 5 Length of removable rod •

2 3 4 5 Refer to page → 124

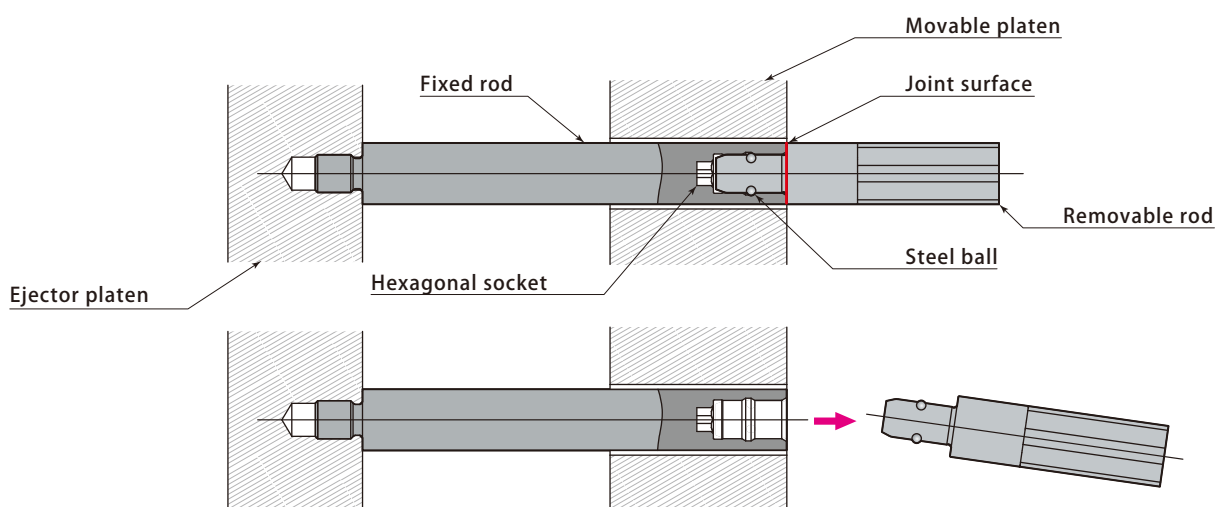

Model		MEL26	MEL40
Rod diameter	mm	$\phi 26$	$\phi 40$
Applied IMM	Clamping force	kN (ton)	13000 (1300) or less
	Loading direction		Vertical loading, Horizontal loading

Rod dimensions

An existing ejector rod can be used with Ball lock ejector rod.
Then Ball lock ejector rod can be used immediately .

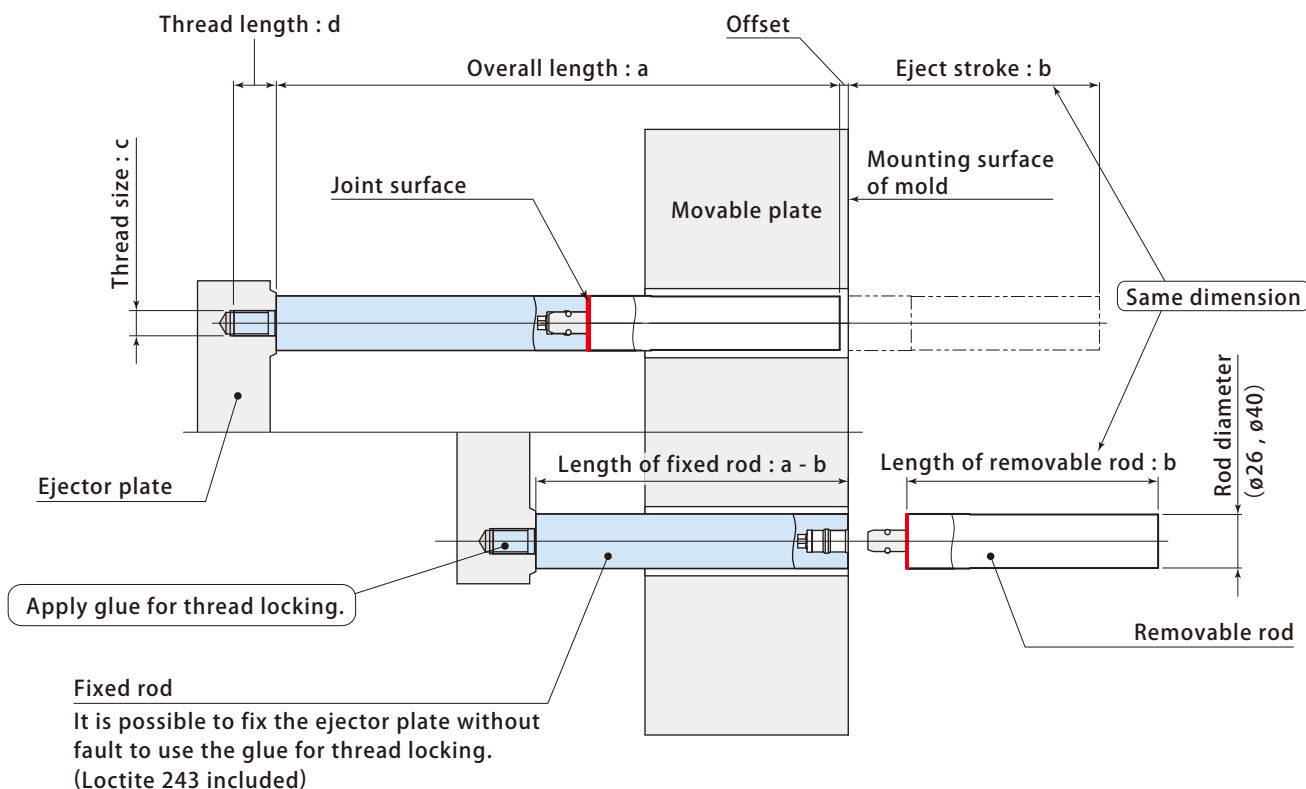

- Upon confirming machine model or above dimensions $\langle a,b,c,d \rangle$, Pascal will calculate rod dimensions.
- If special specification is required, please contact Pascal.
- In case the inclination angle of fixed rod is large, the load for joint surface causes some damage. Contact Pascal for details.

Fixed rod

Model	MEL26F	MEL40F
Rod diameter mm	ø26	ø40
Length of fixed rod : a - b mm	120 and over	

- The length of fixed rod is different from the Easy ejector rod.

Removable rod

Model	MEL26R	MEL40R
Rod diameter mm	ø26	ø40
Eject stroke : b (Length of removable rod) mm	70 ~ 350	70 ~ 350



Fixed rod Jig rod

Model	MEJ26T	MEJ40T
Rod diameter mm	ø26	ø40

- Mounting jig has the same specification as the Easy ejector.
- Mounting jig must be purchased as a set. Jig rod can be used repeatedly .

The cost saving, easy-to-use and simple system by using basic type of clamp.

Recommended to those who

- Intends to reduce initial cost for auto clamp and increase installation rate.
- Intends to have simply clamp / unclamp the mold automatically.

Conventional auto clamp system



Operation panel ELC-B



Orientation of Operation panel ELC-B

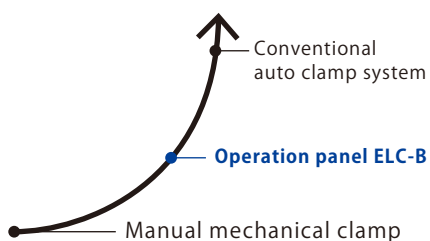

New system that is located in middle position between manual mechanical clamp and conventional auto clamp system.

Differences between auto clamp system and Operation panel ELC-B

- Operation panel ELC-B is not applicable to bolted or automatic slidable type of clamp.

Hydraulic clamp					Air clamp			
TYA	TYC-Z/R	TYA-M	TME	TKB	TLC	TLC-Z/R	TLA-M	TLA
○	×	○	×	×	○	×	○	*○

*Clamped and Unclamped status are confirmed only by an air pressure switch.

- Gang control with other systems except clamp is disabled. (Mold changer system, Auto coupler and so on.)

Operation panel

model ELC-B PAT.

<MOLD CHANGE>KEY LOCK sw.
MOLD / CHANGE

Switch to "MOLD CHANGE" to change a mold.

MOVABLE PLATEN sw.
CLAMP / UNCLAMP

Switch between CLAMP and UNCLAMP.
CLAMP / UNCLAMP operation is feasible only when interlock signals are all ready.



Compact design panel with L-shape mounting bracket enables installation near machine panel.



FIXED PLATEN sw.
CLAMP / UNCLAMP

Switch between CLAMP and UNCLAMP.
CLAMP / UNCLAMP operation is feasible only when interlock signals are all ready.

INTERLOCK button sw.
Lamp ON / OFF

Lamp is ON when interlock signals are ready.
Select clamp with interlock button switch depressed when CLAMP / UNCLAMP operation.
* Bimanual operation

Operation panel
ELC-B

Control unit

(To be installed in the machine control panel)

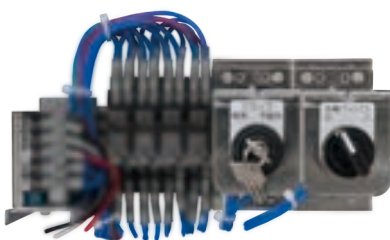

INTERLOCK: ① MOLD-SET MODE, ② MOLD CLOSING LIMIT are monitored.

< Interface between machine and system >

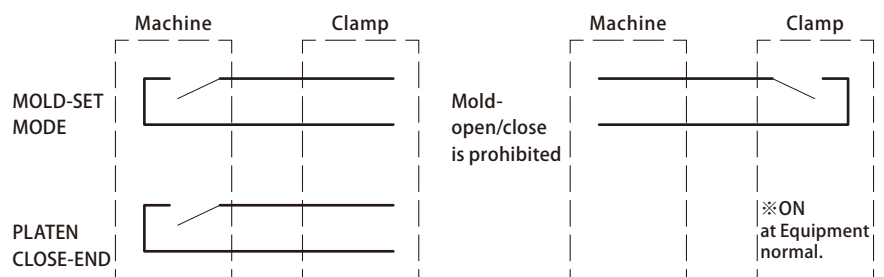

1. Signals to be output on normally open, zero-potential contacts.
2. Contact specification : DC24V/AC100~200V 1A
3. Output "platen closed-end" (Machine daylight adjusted or mold contact) signal alone to the system.

● The criterion for selection of hydraulic control unit stays same with that of conventional auto clamp system.

Mold rotator

Roller gear driven type model **SMR**

It can flip the heavy materials such as mold, coil and castings part with safety and rapidity. Model SMR rotates the table with high rigidity roller gear and large sized sprocket, which enables excellent in durability and safety by introducing roller gear driven type (PAT.)

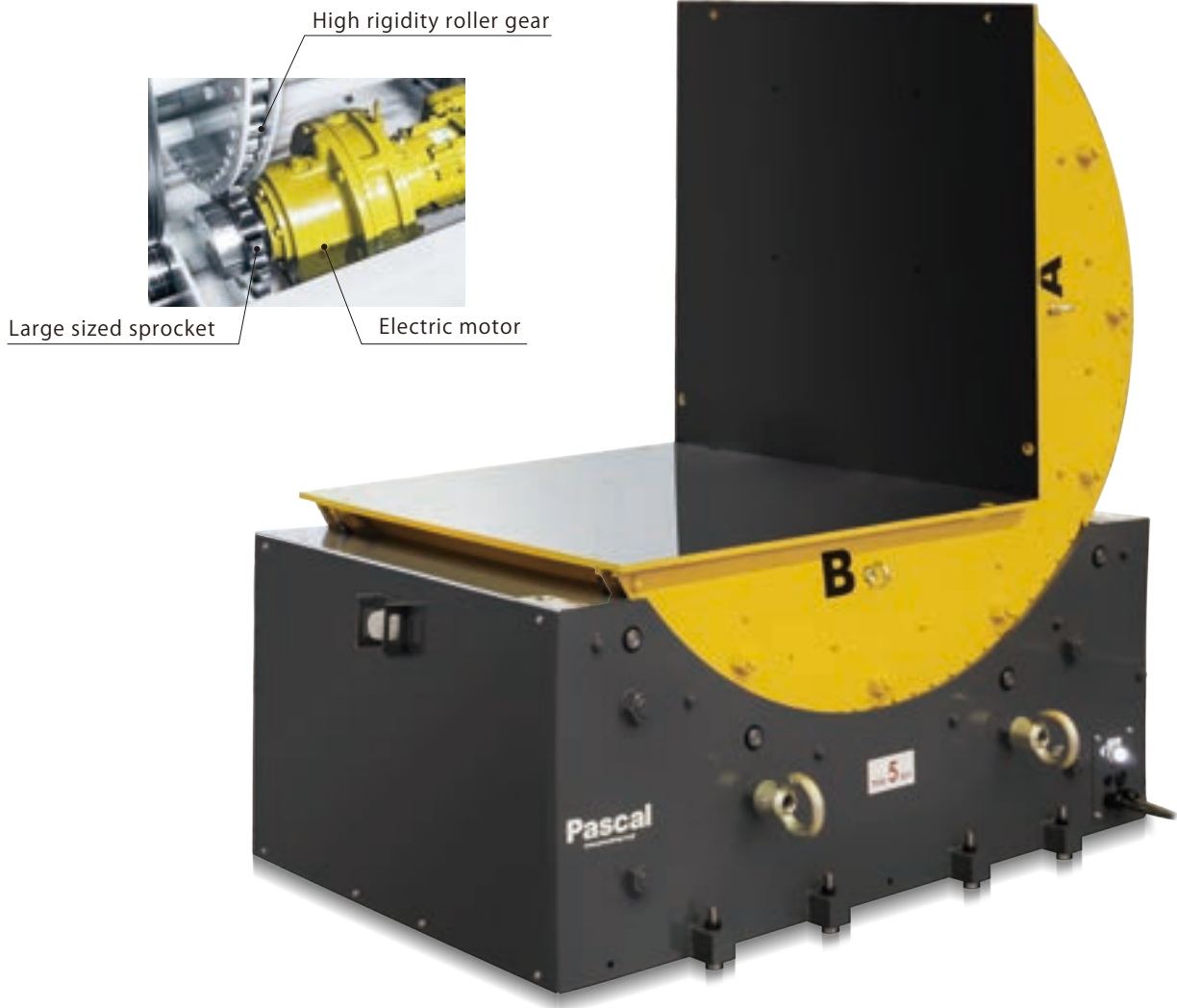

Flat type model **SMF**

Model SMF is embeddable and flattable. The table is rigid enough to be passed over by a forklift or a truck.

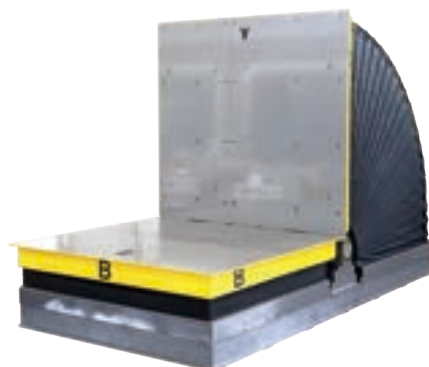

Mold changer

It is automatic mold changer which can shorten the mold changing time considerably, compared with the conventional forklift or overhead crane.

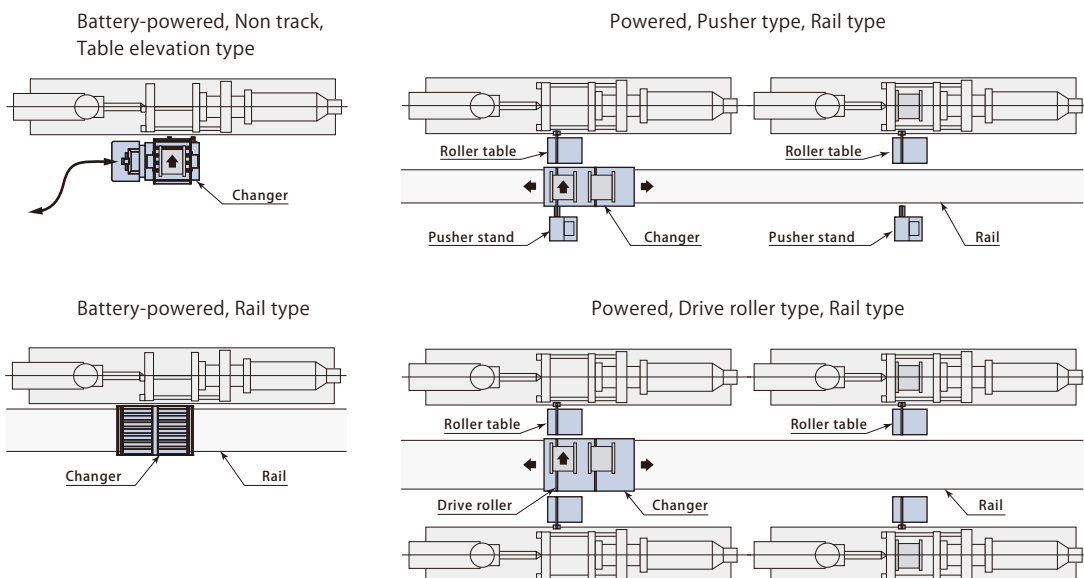

Auto coupler

The introduction of auto coupler enables the connection/disconnection of hydraulic, cooling water and air pressure line or electric connectors at one touch operation at once. It improves the work efficiency at mold changing significantly, also, helps eliminating a human error such as the misplace or misconnection of couplers.

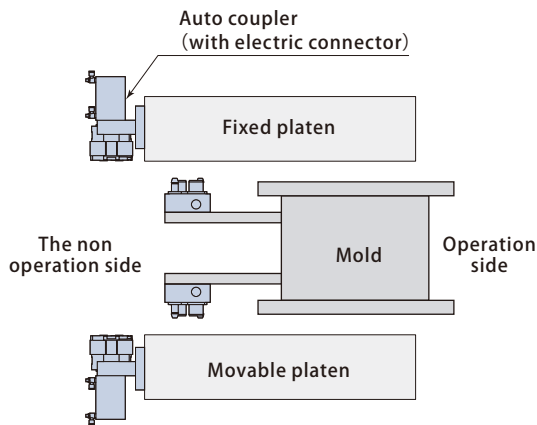
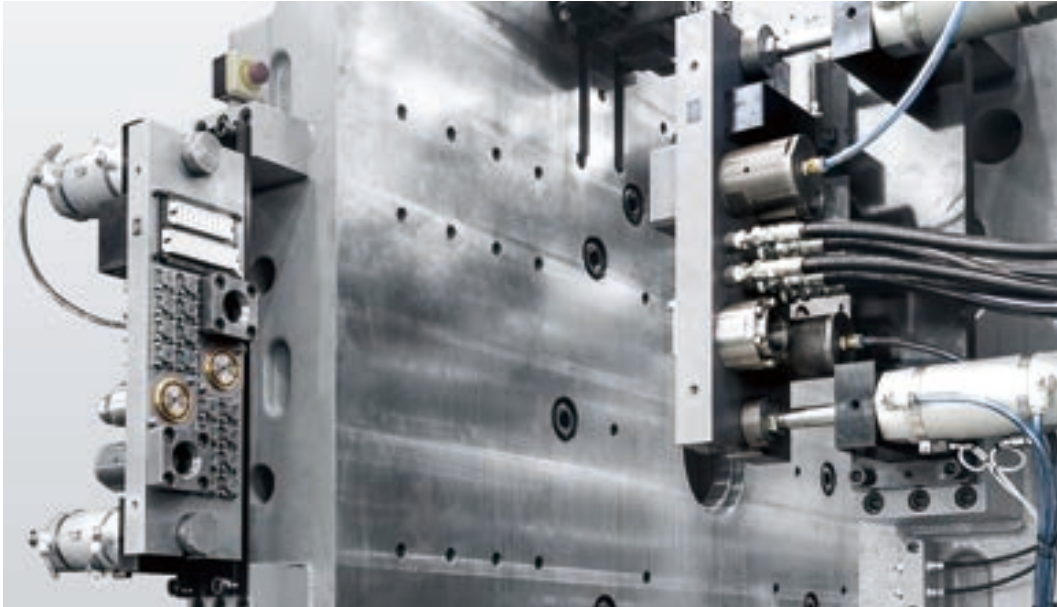

Fluid used	Hydraulic, Water, Air						
Size	3/8"	1/2"	3/4"	1"	1 1/4"	1 1/2"	2"

C&C coupler PAT.

It is the simple mechanism of coupler which maintains connection by the mold clamp.

Fluid used : water, air, hydraulic (Max. 1MPa)

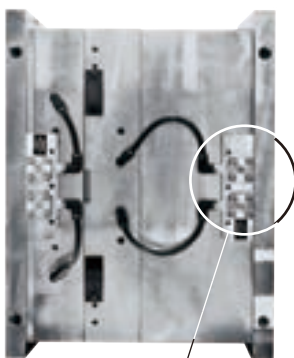

C&C coupler
mold side

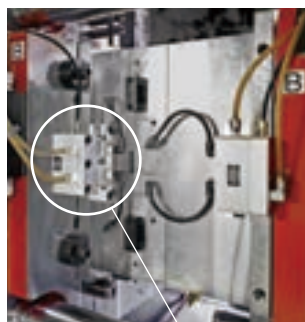

C&C coupler

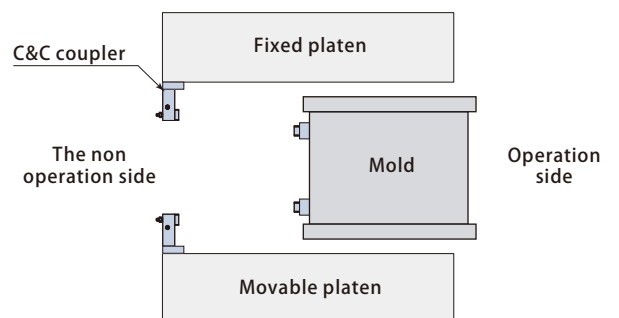

Multi coupler

It is an integrated manual coupler which can connect the couplers all together at one touch operation. It can shorten the connect/disconnect time of couplers and can prevent the misplace. In addition, it is equipped with the lock guide mechanism to ensure an excellent operation.



Fluid used	hydraulic, water, air
Number of port Check valve model	4, 6, 8
Number of port Open model	6, 8, 12

Robot tool changer

It is the unit to exchange the gripper of pick-up robot automatically.



N2 gas spring

For quick cam or ejector plate return.



Pascal all products

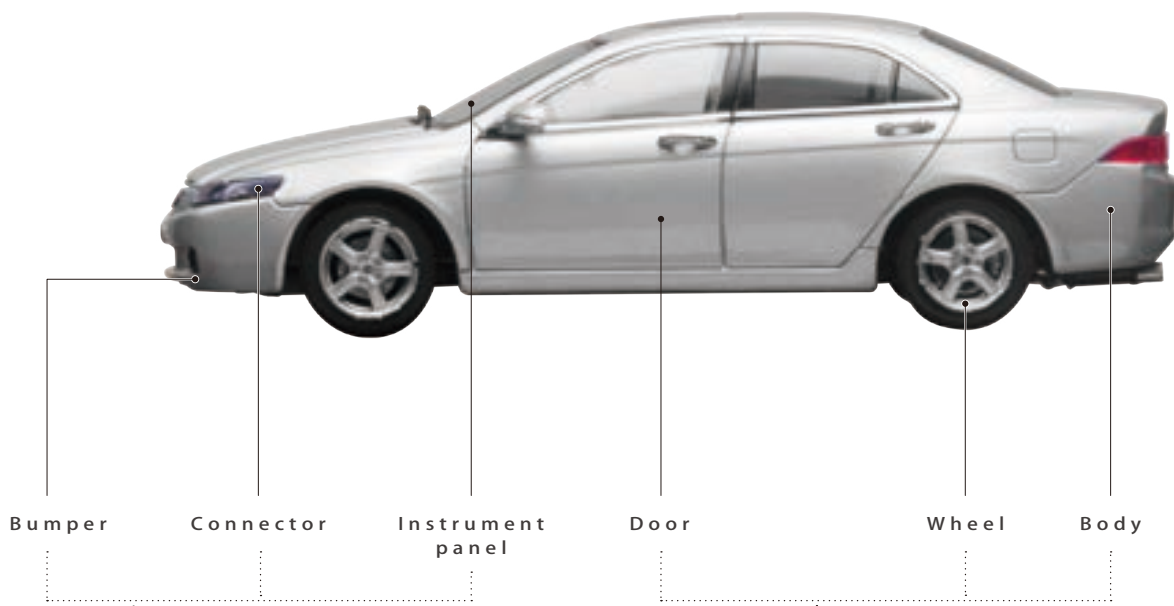

For plastic molding



Mag clamp



Mold die clamping system

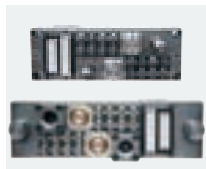

Auto coupler

For sheetmetal stamping



Traveling clamp



Stamping die clamp

For automotive parts die & mold



N2 gas springs

Press machine :
Body , Roof , Door
etc...

Molding machine :
Bumper ,
Instrument panel
etc...

Pascal products support
automotive production lines globally.

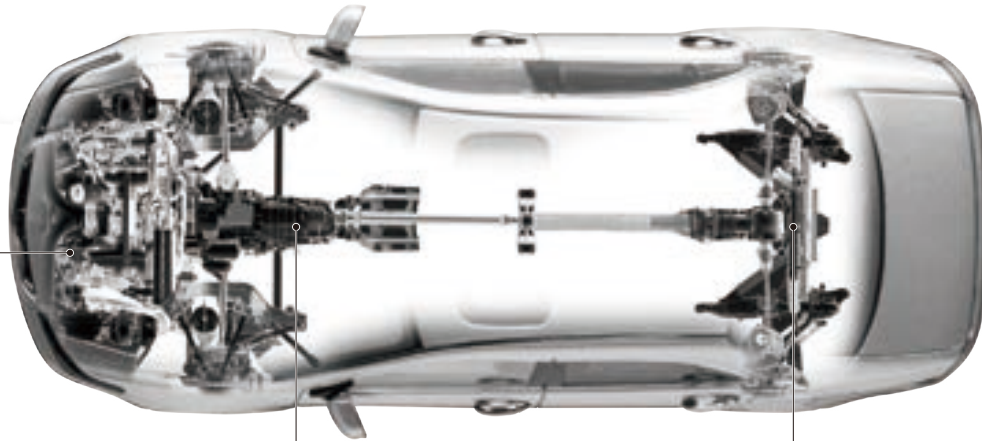

Engine

Transmission

Axle

For die cast machine



Die-clamping
system



C-plate mag clamp

For metal cutting work



Work clamp



Pallet clamp



Index table



N2 gas balancer

DOMESTIC LOCATIONS

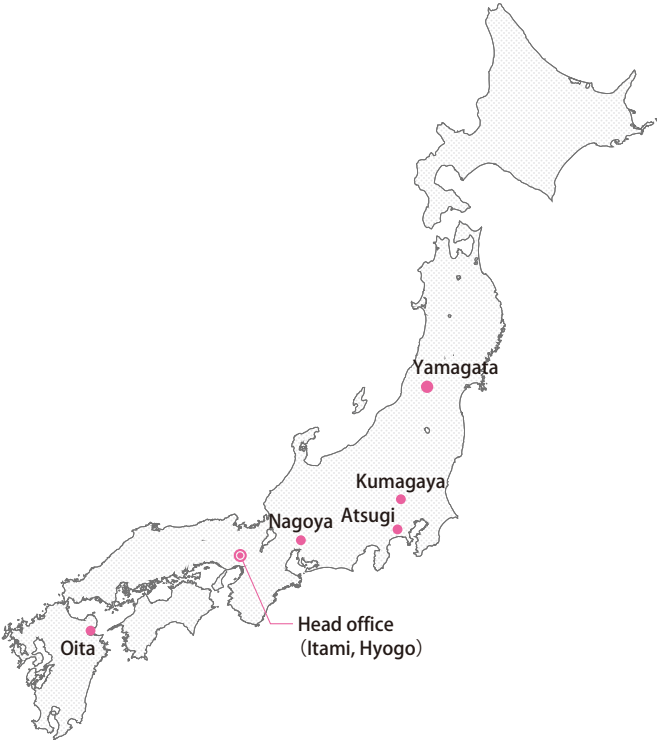

JAPAN

Head office / R & D center ● Itami, Hyogo

Sales office ● Osaka, Hyogo
 ● Kumagaya, Saitama,
 ● Atsugi, Kanagawa
 ● Nagoya, Aichi
 ● Yamagata

Plant ● Oita
 ● Yamagata



Head office / R & D center



Oita plant



Yamagata plant

GLOBAL NETWORK

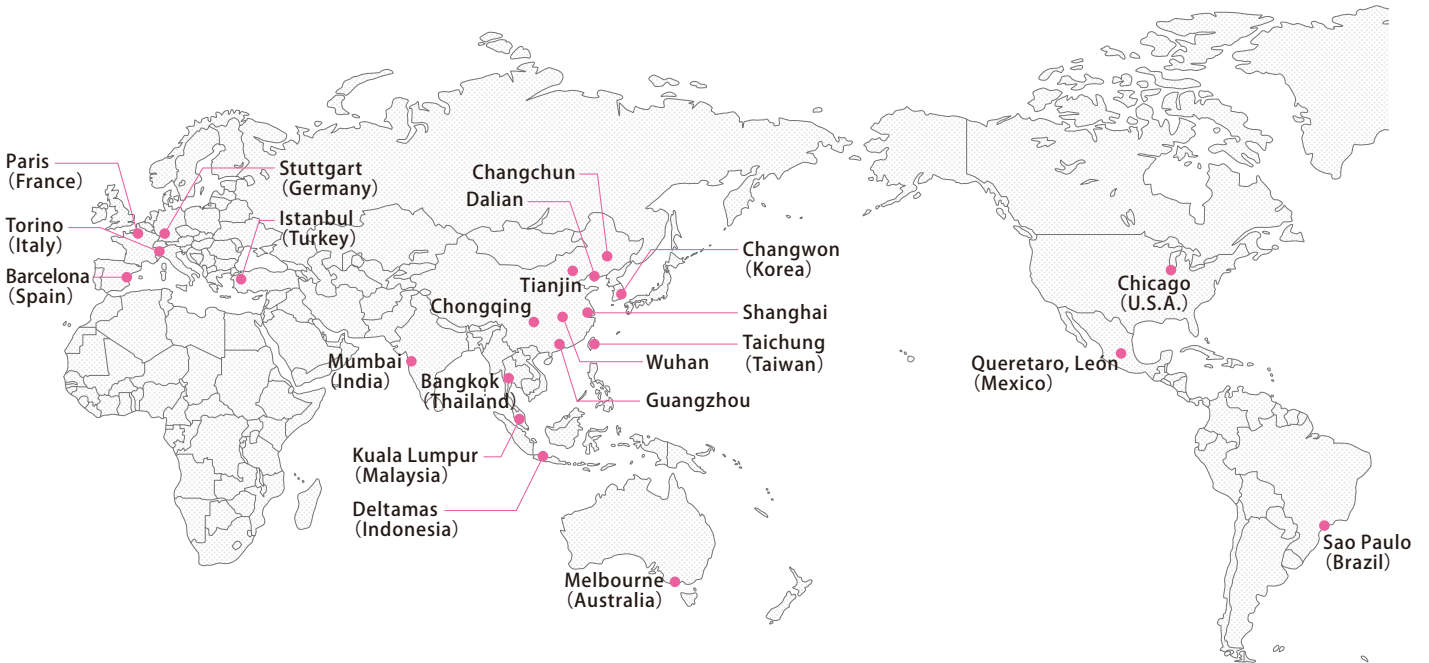

ASIA





- | | |
|---|---|
|  Dalian [China] |  Taichung [Taiwan] |
|  Shanghai [China] |  Bangkok [Thailand] |
|  Changchun [China] |  Changwon [Korea] |
|  Tianjin [China] |  Deltamas [Indonesia] |
|  Wuhan [China] |  Kuala Lumpur [Malaysia] |
|  Chongqing [China] |  Mumbai [India] |
|  Guangzhou [China] |  Melbourne [Australia] |

● Plant ● Subsidiary ● Sales office ● Liaison office ○ Agent

AMERICA

- | |
|--|
|  Chicago [U.S.A.] |
|  Queretaro , León [Mexico] |
|  Sao Paulo [Brazil] |

EUROPE

- | |
|--|
|  Stuttgart [Germany] |
|  Torino [Italy] |
|  Paris [France] |
|  Barcelona [Spain] |
|  Istanbul [Turkey] |

Pascal

corporation

Itami, Hyogo, Japan 664-8502
TEL. +81-72-777-3333 FAX. +81-72-777-3520

Chicago, U.S.A.	TEL. +1-847-427-1234
Stuttgart, Germany	TEL. +49-711-782-850-0
Dalian, China	TEL. +86-411-8732-2988
Shanghai, China	TEL. +86-21-5263-4122
Changwon, Korea	TEL. +82-55-274-0971
Bangkok, Thailand	TEL. +66-2173-5855

